

UNIT 5

Shafts & Couplings

Shafts:

A shaft is a rotating machine element which is used to transmit power from one place to another. The power is delivered to the shaft by some tangential force and the resultant torque (or twisting moment) set up within the shaft permits the power to be transferred to various machines linked up to the shaft. In order to transfer the power from one shaft to another, the various members such as pulleys, gears etc., are mounted on it. These members along with the forces exerted upon them causes the shaft to bending.

In other words, we may say that a shaft is used for the transmission of torque and bending moment. The various members are mounted on the shaft by means of keys or splines. The shafts are usually cylindrical, but may be square or cross-shaped in section. They are solid in cross-section but sometimes hollow shafts are also used. An *axle*, though similar in shape to the shaft, is a stationary machine element and is used for the transmission of bending moment only. It simply acts as a support for some rotating body such as hoisting drum, a car wheel or a rope sheave. A *spindle* is a short shaft that imparts motion either to a cutting tool (*e.g.* drill press spindles) or to a work piece (*e.g.* lathe spindles).

Types of Shafts

The following two types of shafts are important from the subject point of view:

1. **Transmission shafts.** These shafts transmit power between the source and the machines absorbing power. The counter shafts, line shafts, over head shafts and all factory shafts are transmission shafts. Since these shafts carry machine parts such as pulleys, gears etc., therefore they are subjected to bending in addition to twisting.
2. **Machine shafts.** These shafts form an integral part of the machine itself. The crank shaft is an example of machine shaft.

Stresses in Shafts

The following stresses are induced in the shafts:

1. Shear stresses due to the transmission of torque (*i.e.* due to torsional load).
2. Bending stresses (tensile or compressive) due to the forces acting upon machine elements like gears, pulleys etc. as well as due to the weight of the shaft itself.
3. Stresses due to combined torsional and bending loads.

Design of Shafts

The shafts may be designed on the basis of

1. Strength, and 2. Rigidity and stiffness.

In designing shafts on the basis of strength, the following cases may be considered:

- (a) Shafts subjected to twisting moment or torque only,
- (b) Shafts subjected to bending moment only,
- (c) Shafts subjected to combined twisting and bending moments, and
- (d) Shafts subjected to axial loads in addition to combined torsional and bending loads.

Shafts Subjected to Twisting Moment Only

a) Solid shaft:

When the shaft is subjected to a twisting moment (or torque) only, then the diameter of the shaft may be obtained by using the torsion equation. We know that

$$\frac{T}{J} = \frac{\tau}{r}$$

Where T = Twisting moment (or torque) acting upon the shaft,

J = Polar moment of inertia of the shaft about the axis of rotation,

τ = Torsional shear stress, and

r = Distance from neutral axis to the outer most fibre

= $d/2$; where d is the diameter of the shaft.

We know that for round solid shaft, polar moment of inertia,

$$J = \frac{\pi}{32} d^4$$

Then we get,

$$T = \frac{\tau}{16} d^3$$

From this equation, diameter of the solid shaft (d) may be obtained.

b) Hollow Shaft:

We also know that for hollow shaft, polar moment of inertia,

$$J = \frac{\pi}{32} [(d_o)^4 - (d_i)^4]$$

Where d_o and d_i = Outside and inside diameter of the shaft, and $r = d_o/2$.

Substituting these values in equation (i), we have

$$\frac{T}{\frac{\pi}{32} [(d_o)^4 - (d_i)^4]} = \frac{\tau}{\frac{d_o}{2}} \quad \text{or} \quad T = \frac{\pi}{16} \times \tau \left[\frac{(d_o)^4 - (d_i)^4}{d_o} \right]$$

Let k = Ratio of inside diameter and outside diameter of the shaft = d_i/d_o

Now the equation (iii) may be written as

$$T = \frac{\pi}{16} \times \tau \times \frac{(d_o)^4}{d_o} \left[1 - \left(\frac{d_i}{d_o} \right)^4 \right] = \frac{\pi}{16} \times \tau (d_o)^3 (1 - k^4)$$

From the equations, the outside and inside diameter of a hollow shaft may be determined.

It may be noted that

1. The hollow shafts are usually used in marine work. These shafts are stronger per kg of material and they may be forged on a mandrel, thus making the material more homogeneous than would be possible for a solid shaft. When a hollow shaft is to be made equal in strength to a solid shaft, the twisting moment of both the shafts must be same. In other words, for the same material of both the shafts,

$$T = \frac{\pi}{16} \times \tau \left[\frac{(d_o)^4 - (d_i)^4}{d_o} \right] = \frac{\pi}{16} \times \tau \times d^3$$

$$\therefore \frac{(d_o)^4 - (d_i)^4}{d_o} = d^3 \quad \text{or} \quad (d_o)^3 (1 - k^4) = d^3$$

2. The twisting moment (T) may be obtained by using the following relation:

We know that the power transmitted (in watts) by the shaft,

$$P = \frac{2\pi N \times T}{60} \quad \text{or} \quad T = \frac{P \times 60}{2\pi N}$$

Where T = Twisting moment in N-m, and

N = Speed of the shaft in r.p.m.

3. In case of belt drives, the twisting moment (T) is given by

$$T = (T_1 - T_2) R$$

Where T_1 and T_2 = Tensions in the tight side and slack side of the belt respectively, and R = Radius of the pulley.

Shafts Subjected to Bending Moment Only

a) Solid Shaft:

When the shaft is subjected to a bending moment only, then the maximum stress (tensile or compressive) is given by the bending equation. We know that

$$\frac{M}{I} = \frac{\sigma_b}{y}$$

Where M = Bending moment,

I = Moment of inertia of cross-sectional area of the shaft about the axis of rotation,

σ_b = Bending stress, and

y = Distance from neutral axis to the outer-most fibre.

We know that for a round solid shaft, moment of inertia,

$$I = \frac{\pi}{64} \times d^4 \quad \text{and} \quad y = \frac{d}{2}$$

Substituting these values in equation

$$\frac{M}{\frac{\pi}{64} \times d^4} = \frac{\sigma_b}{\frac{d}{2}} \quad \text{or} \quad M = \frac{\pi}{32} \times \sigma_b \times d^3$$

From this equation, diameter of the solid shaft (d) may be obtained.

b) Hollow Shaft:

We also know that for a hollow shaft, moment of inertia,

$$I = \frac{\pi}{64} [(d_o)^4 - (d_i)^4] = \frac{\pi}{64} (d_o)^4 (1 - k^4) \quad \dots (\text{where } k = d_i / d_o)$$

And $y = d_o / 2$

Again substituting these values in equation, we have

$$\frac{M}{\frac{\pi}{64} (d_o)^4 (1 - k^4)} = \frac{\sigma_b}{\frac{d_o}{2}} \quad \text{or} \quad M = \frac{\pi}{32} \times \sigma_b (d_o)^3 (1 - k^4)$$

From this equation, the outside diameter of the shaft (d_o) may be obtained.

Shafts Subjected to Combined Twisting Moment and Bending Moment

When the shaft is subjected to combined twisting moment and bending moment, then the shaft must be designed on the basis of the two moments simultaneously. Various theories have been suggested to account for the elastic failure of the materials when they are subjected to various types of combined stresses. The following two theories are important from the subject point of view:

1. Maximum shear stress theory or Guest's theory. It is used for ductile materials such as mild steel.
2. Maximum normal stress theory or Rankine's theory. It is used for brittle materials such as cast iron.

Let τ = Shear stress induced due to twisting moment, and

σ_b = Bending stress (tensile or compressive) induced due to bending moment.

a) Solid Shaft:

According to maximum shear stress theory, the maximum shear stress in the shaft,

$$\tau_{max} = \frac{1}{2} \sqrt{(\sigma_b)^2 + 4\tau^2}$$

Substituting the values of σ_b and τ

$$\tau_{max} = \frac{1}{2} \sqrt{\left(\frac{32M}{\pi d^3}\right)^2 + 4\left(\frac{16T}{\pi d^3}\right)^2} = \frac{16}{\pi d^3} \left[\sqrt{M^2 + T^2}\right]$$

$$\text{or} \quad \frac{\pi}{16} \times \tau_{max} \times d^3 = \sqrt{M^2 + T^2}$$

The expression $\sqrt{M^2 + T^2}$ is known as **equivalent twisting moment** and is denoted by T_e . The equivalent twisting moment may be defined as that twisting moment, which when acting alone, produces the same shear stress (τ) as the actual twisting moment. By limiting the maximum shear stress (τ_{max}) equal to the allowable shear stress (τ) for the material, the equation (i) may be written as

$$T_e = \sqrt{M^2 + T^2} = \frac{\pi}{16} \times \tau \times d^3$$

From this expression, diameter of the shaft (d) may be evaluated.

Now according to maximum normal stress theory, the maximum normal stress in the shaft,

$$\begin{aligned} \sigma_{b(max)} &= \frac{1}{2} \sigma_b + \frac{1}{2} \sqrt{(\sigma_b)^2 + 4\tau^2} \\ &= \frac{1}{2} \times \frac{32M}{\pi d^3} + \frac{1}{2} \sqrt{\left(\frac{32M}{\pi d^3}\right)^2 + 4\left(\frac{16T}{\pi d^3}\right)^2} \\ &= \frac{32}{\pi d^3} \left[\frac{1}{2} (M + \sqrt{M^2 + T^2}) \right] \end{aligned}$$

$$\text{or} \quad \frac{\pi}{32} \times \sigma_{b(max)} \times d^3 = \frac{1}{2} [M + \sqrt{M^2 + T^2}]$$

The expression $\frac{1}{2} [M + \sqrt{M^2 + T^2}]$ is known as **equivalent bending moment** and is denoted

2

by M_e . The equivalent bending moment may be defined as that moment which when acting alone produces the same tensile or compressive stress (σ_b) as the actual bending moment. By limiting the maximum normal stress [$\sigma_{b(max)}$] to the allowable bending stress (σ_b), then the equation (iv) is

$$M_e = \frac{1}{2} [M + \sqrt{M^2 + T^2}] = \frac{\pi}{32} \times \sigma_b \times d^3$$

From this expression, diameter of the shaft (d) may be evaluated.

In case of a hollow shaft, the equations (ii) and (v) may be written as

$$T_s = \sqrt{M^2 + T^2} = \frac{\pi}{16} \times \tau (d_o)^3 (1 - k^4)$$

$$M_s = \frac{1}{2} (M + \sqrt{M^2 + T^2}) = \frac{\pi}{32} \times \sigma_b (d_o)^3 (1 - k^4)$$

It is suggested that diameter of the shaft may be obtained by using both the theories and the larger of the two values is adopted.

References:

1. Machine Design - V. Bandari .
2. Machine Design – R.S. Khurmi
3. Design Data hand Book - S MD Jalaludin.

Problem:

A shaft is supported by two bearings placed 1 m apart. A 600 mm diameter pulley is mounted at a distance of 300 mm to the right of left hand bearing and this drives a pulley directly below it with the help of belt having maximum tension of 2.25 kN. Another pulley 400 mm diameter is placed 200 mm to the left of right hand bearing and is driven with the help of electric motor and belt, which is placed horizontally to the right. The angle of contact for both the pulleys is 180° and $\mu = 0.24$. Determine the suitable diameter for a solid shaft, allowing working stress of 63 MPa in tension and 42 MPa in shear for the material of shaft. Assume that the torque on one pulley is equal to that on the other pulley.

Solution. Given : $AB = 800$ mm ; $\alpha_C = 20^\circ$; $D_C = 600$ mm or $R_C = 300$ mm ; $AC = 200$ mm ; $D_D = 700$ mm or $R_D = 350$ mm ; $DB = 250$ mm ; $\theta = 180^\circ = \pi$ rad ; $W = 2000$ N ; $T_1 = 3000$ N ; $T_1/T_2 = 3$; $\tau = 40$ MPa = 40 N/mm²

The space diagram of the shaft is shown in Fig (a).

We know that the torque acting on the shaft at D ,

$$\begin{aligned} T &= (T_1 - T_2) R_D = T_1 \left(1 - \frac{T_2}{T_1} \right) R_D \\ &= 3000 \left(1 - \frac{1}{3} \right) 350 = 700 \times 10^3 \text{ N-mm} \quad \dots (\because T_1/T_2 = 3) \end{aligned}$$

The torque diagram is shown in Fig. (b).

Assuming that the torque at D is equal to the torque at C , therefore the tangential force acting on the gear C ,

$$F_{tc} = \frac{T}{R_C} = \frac{700 \times 10^3}{300} = 2333 \text{ N}$$

and the normal load acting on the tooth of gear C ,

$$W_C = \frac{F_{tc}}{\cos \alpha_C} = \frac{2333}{\cos 20^\circ} = \frac{2333}{0.9397} = 2483 \text{ N}$$

The normal load acts at 20° to the vertical as shown in Fig. Resolving the normal load vertically and horizontally, we get

Vertical component of W_C i.e. the vertical load acting on the shaft at C ,

$$\begin{aligned} W_{CV} &= W_C \cos 20^\circ \\ &= 2483 \times 0.9397 = 2333 \text{ N} \end{aligned}$$

and horizontal component of W_C i.e. the horizontal load acting on the shaft at C ,

$$\begin{aligned} W_{CH} &= W_C \sin 20^\circ \\ &= 2483 \times 0.342 = 849 \text{ N} \end{aligned}$$

Since $T_1/T_2 = 3$ and $T_1 = 3000$ N, therefore

$$T_2 = T_1 / 3 = 3000 / 3 = 1000 \text{ N}$$

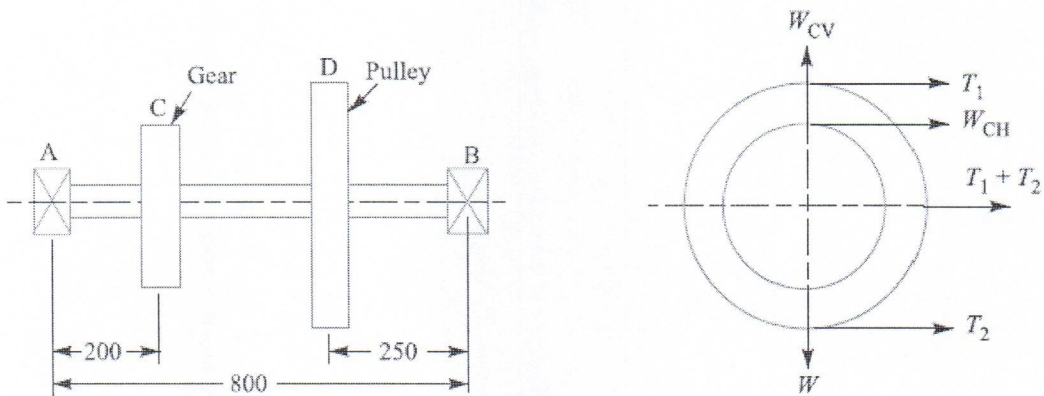

All dimensions in mm.

(a) Space diagram.

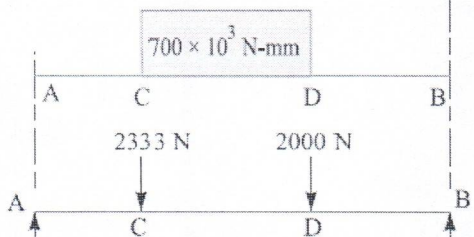

(b) Torque diagram.

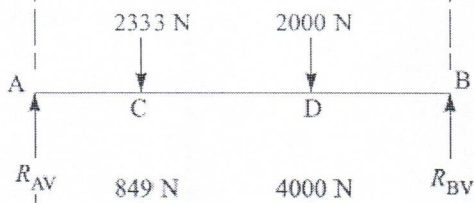

(c) Vertical load diagram.

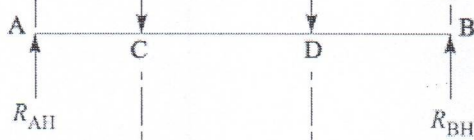

(d) Horizontal load diagram.

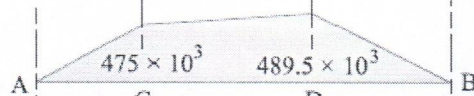

(e) Vertical B.M. diagram.

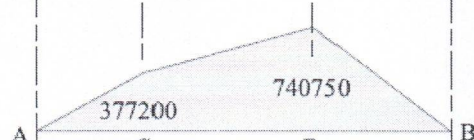

(f) Horizontal B.M. diagram.

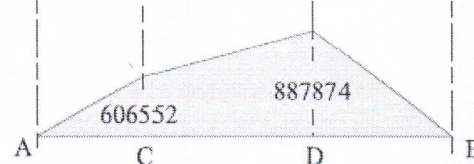

(g) Resultant B.M. diagram.

∴ Horizontal load acting on the shaft at D ,

$$W_{DH} = T_1 + T_2 = 3000 + 1000 = 4000 \text{ N}$$

and vertical load acting on the shaft at D ,

$$W_{DV} = W = 2000 \text{ N}$$

The vertical and horizontal load diagram at C and D is shown in Fig. 14.6 (c) and (d) respectively.

Now let us find the maximum bending moment for vertical and horizontal loading.

First of all considering the vertical loading at C and D . Let R_{AV} and R_{BV} be the reactions at the bearings A and B respectively. We know that

$$R_{AV} + R_{BV} = 2333 + 2000 = 4333 \text{ N}$$

Taking moments about A , we get

$$\begin{aligned} R_{BV} \times 800 &= 2000(800 - 250) + 2333 \times 200 \\ &= 1\,565\,600 \end{aligned}$$

$$\therefore R_{BV} = 1\,565\,600 / 800 = 1958 \text{ N}$$

and $R_{AV} = 4333 - 1958 = 2375 \text{ N}$

We know that B.M. at A and B ,

$$M_{AV} = M_{BV} = 0$$

B.M. at C , $M_{CV} = R_{AV} \times 200 = 2375 \times 200$
 $= 475 \times 10^3 \text{ N-mm}$

B.M. at D , $M_{DV} = R_{BV} \times 250 = 1958 \times 250 = 489.5 \times 10^3 \text{ N-mm}$

The bending moment diagram for vertical loading is shown in Fig. 14.6 (e).

Now consider the horizontal loading at C and D . Let R_{AH} and R_{BH} be the reactions at the bearings A and B respectively. We know that

$$R_{AH} + R_{BH} = 849 + 4000 = 4849 \text{ N}$$

Taking moments about A , we get

$$R_{BH} \times 800 = 4000(800 - 250) + 849 \times 200 = 2\,369\,800$$

$$\therefore R_{BH} = 2\,369\,800 / 800 = 2963 \text{ N}$$

and $R_{AH} = 4849 - 2963 = 1886 \text{ N}$

We know that B.M. at A and B ,

$$M_{AH} = M_{BH} = 0$$

B.M. at C , $M_{CH} = R_{AH} \times 200 = 1886 \times 200 = 377\,200 \text{ N-mm}$

B.M. at D , $M_{DH} = R_{BH} \times 250 = 2963 \times 250 = 740\,750 \text{ N-mm}$

The bending moment diagram for horizontal loading is shown in Fig. 14.6 (f).

We know that resultant B.M. at C ,

$$\begin{aligned} M_C &= \sqrt{(M_{CV})^2 + (M_{CH})^2} = \sqrt{(475 \times 10^3)^2 + (377\,200)^2} \\ &= 606\,552 \text{ N-mm} \end{aligned}$$

and resultant B.M. at D ,

$$\begin{aligned} M_D &= \sqrt{(M_{DV})^2 + (M_{DH})^2} = \sqrt{(489.5 \times 10^3)^2 + (740\,750)^2} \\ &= 887\,874 \text{ N-mm} \end{aligned}$$

Maximum bending moment

The resultant B.M. diagram is shown in Fig. 14.6 (g). We see that the bending moment is maximum at D , therefore

Maximum B.M., $M = M_D = 887\,874 \text{ N-mm Ans.}$

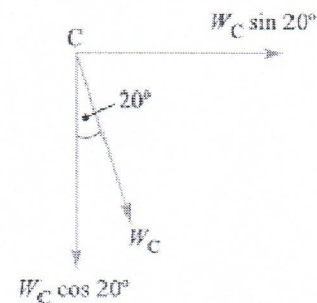

Fig. 14.7

Diameter of the shaft

Let d = Diameter of the shaft.

We know that the equivalent twisting moment,

$$T_e = \sqrt{M^2 + T^2} = \sqrt{(887\ 874)^2 + (700 \times 10^3)^2} = 1131 \times 10^3 \text{ N-mm}$$

We also know that equivalent twisting moment (T_e),

$$1131 \times 10^3 = \frac{\pi}{16} \times \tau \times d^3 = \frac{\pi}{16} \times 40 \times d^3 = 7.86 d^3$$

$$\therefore d^3 = 1131 \times 10^3 / 7.86 = 144 \times 10^3 \text{ or } d = 52.4 \text{ say } 55 \text{ mm Ans.}$$

Problem:

A steel solid shaft transmitting 15 kW at 200 r.p.m. is supported on two bearings 750 mm apart and has two gears keyed to it. The pinion having 30 teeth of 5 mm module is located 100 mm to the left of the right hand bearing and delivers power horizontally to the right. The gear having 100 teeth of 5 mm module is located 150 mm to the right of the left hand bearing and receives power in a vertical direction from below. Using an allowable stress of 54 MPa in shear, determine the diameter of the shaft.

Solution. Given : $P = 15 \text{ kW} = 15 \times 10^3 \text{ W}$; $N = 200 \text{ r.p.m.}$; $AB = 750 \text{ mm}$; $T_D = 30$; $m_D = 5 \text{ mm}$; $BD = 100 \text{ mm}$; $T_C = 100$; $m_C = 5 \text{ mm}$; $AC = 150 \text{ mm}$; $\tau = 54 \text{ MPa} = 54 \text{ N/mm}^2$

The space diagram of the shaft is shown in Fig. 14.8 (a).

We know that the torque transmitted by the shaft,

$$T = \frac{P \times 60}{2\pi N} = \frac{15 \times 10^3 \times 60}{2\pi \times 200} = 716 \text{ N-m} = 716 \times 10^3 \text{ N-mm}$$

The torque diagram is shown in Fig. 14.8 (b).

We know that diameter of gear

$$= \text{No. of teeth on the gear} \times \text{module}$$

\therefore Radius of gear C,

$$R_C = \frac{T_C \times m_C}{2} = \frac{100 \times 5}{2} = 250 \text{ mm}$$

and radius of pinion D,

$$R_D = \frac{T_D \times m_D}{2} = \frac{30 \times 5}{2} = 75 \text{ mm}$$

Assuming that the torque at C and D is same (i.e. $716 \times 10^3 \text{ N-mm}$), therefore tangential force on the gear C, acting downward,

$$F_{tC} = \frac{T}{R_C} = \frac{716 \times 10^3}{250} = 2870 \text{ N}$$

and tangential force on the pinion D, acting horizontally,

$$F_{tD} = \frac{T}{R_D} = \frac{716 \times 10^3}{75} = 9550 \text{ N}$$

The vertical and horizontal load diagram is shown in Fig. 14.8 (c) and (d) respectively.

Now let us find the maximum bending moment for vertical and horizontal loading.

First of all, considering the vertical loading at C. Let R_{AV} and R_{BV} be the reactions at the bearings A and B respectively. We know that

$$R_{AV} + R_{BV} = 2870 \text{ N}$$

Taking moments about A, we get

$$R_{BV} \times 750 - 2870 \times 150 = 0$$

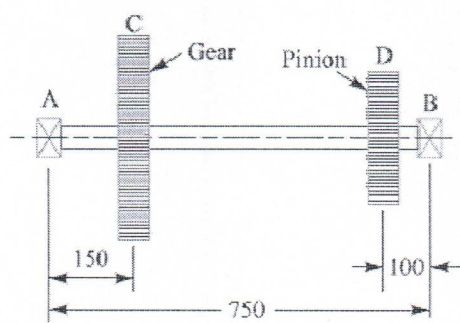

All dimensions in mm.

(a) Space diagram.

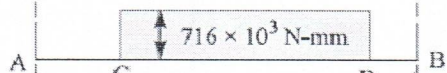
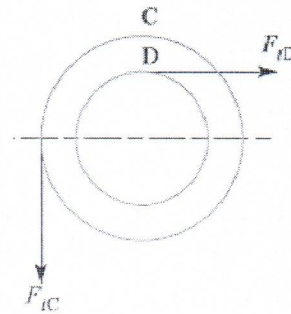

(b) Torque diagram.

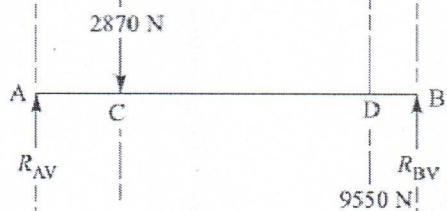

(c) Vertical load diagram.

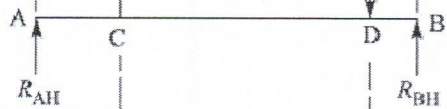

(d) Horizontal load diagram.

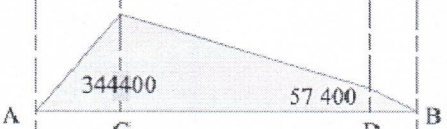

(e) Vertical B.M. diagram.

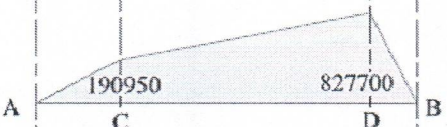

(f) Horizontal B.M. diagram.

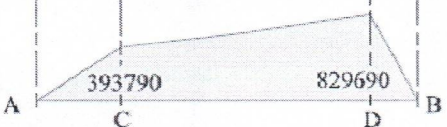

(g) Resultant B.M. diagram.

$$\therefore R_{BV} = 2870 \times 150 / 750 = 574 \text{ N}$$

and $R_{AV} = 2870 - 574 = 2296 \text{ N}$

We know that B.M. at A and B ,

$$M_{AV} = M_{BV} = 0$$

B.M. at C , $M_{CV} = R_{AV} \times 150 = 2296 \times 150 = 344\,400 \text{ N-mm}$

B.M. at D , $M_{DV} = R_{BV} \times 100 = 574 \times 100 = 57\,400 \text{ N-mm}$

The B.M. diagram for vertical loading is shown in Fig. 14.8 (e).

Now considering horizontal loading at D . Let R_{AH} and R_{BH} be the reactions at the bearings A and B respectively. We know that

$$R_{AH} + R_{BH} = 9550 \text{ N}$$

Taking moments about A , we get

$$R_{BH} \times 750 = 9550 (750 - 100) = 9550 \times 650$$

$$\therefore R_{BH} = 9550 \times 650 / 750 = 8277 \text{ N}$$

and $R_{AH} = 9550 - 8277 = 1273 \text{ N}$

We know that B.M. at A and B ,

$$M_{AH} = M_{BH} = 0$$

B.M. at C , $M_{CH} = R_{AH} \times 150 = 1273 \times 150 = 190\,950 \text{ N-mm}$

B.M. at D , $M_{DH} = R_{BH} \times 100 = 8277 \times 100 = 827\,700 \text{ N-mm}$

The B.M. diagram for horizontal loading is shown in Fig. 14.8 (f).

We know that resultant B.M. at C ,

$$M_C = \sqrt{(M_{CV})^2 + (M_{CH})^2} = \sqrt{(344\,400)^2 + (190\,950)^2} \\ = 393\,790 \text{ N-mm}$$

and resultant B.M. at D ,

$$M_D = \sqrt{(M_{DV})^2 + (M_{DH})^2} = \sqrt{(57\,400)^2 + (827\,700)^2} \\ = 829\,690 \text{ N-mm}$$

The resultant B.M. diagram is shown in Fig. 14.8 (g). We see that the bending moment is maximum at D .

\therefore Maximum bending moment,

$$M = M_D = 829\,690 \text{ N-mm}$$

Let d = Diameter of the shaft.

We know that the equivalent twisting moment,

$$T_e = \sqrt{M^2 + T^2} = \sqrt{(829\,690)^2 + (716 \times 10^3)^2} = 1096 \times 10^3 \text{ N-mm}$$

We also know that equivalent twisting moment (T_e),

$$1096 \times 10^3 = \frac{\pi}{16} \times \tau \times d^3 = \frac{\pi}{16} \times 54 \times d^3 = 10.6 d^3$$

$$\therefore d^3 = 1096 \times 10^3 / 10.6 = 103.4 \times 10^3$$

or $d = 47 \text{ say } 50 \text{ mm Ans.}$

References:

1. Machine Design - V. Bandari .

2. Machine Design – R.S. Khurmi

3. Design Data hand Book - S MD Jalaludin.

Shafts Subjected to Axial Load in addition to Combined Torsion and Bending Loads:

When the shaft is subjected to an axial load (F) in addition to torsion and bending loads as in propeller shafts of ships and shafts for driving worm gears, then the stress due to axial load must be added to the bending stress (σ_b). We know that bending equation is

$$\frac{M}{I} = \frac{\sigma_b}{y} \quad \text{or} \quad \sigma_b = \frac{M \cdot y}{I} = \frac{M \times d/2}{\frac{\pi}{64} \times d^4} = \frac{32M}{\pi d^3}$$

And stress due to axial load

$$= \frac{F}{\frac{\pi}{4} \times d^2} = \frac{4F}{\pi d^2} \quad \dots (\text{For round solid shaft})$$

$$= \frac{F}{\frac{\pi}{4} [(d_o)^2 - (d_i)^2]} = \frac{4F}{\pi [(d_o)^2 - (d_i)^2]} \quad \dots (\text{For hollow shaft})$$

$$= \frac{F}{\pi (d_o)^2 (1 - k^2)} \quad \dots (\because k = d_i/d_o)$$

Resultant stress (tensile or compressive) for solid shaft,

$$\sigma_1 = \frac{32M}{\pi d^3} + \frac{4F}{\pi d^2} = \frac{32}{\pi d^3} \left(M + \frac{F \times d}{8} \right) \quad \dots (i)$$

$$= \frac{32M_1}{\pi d^3} \quad \dots \left(\text{Substituting } M_1 = M + \frac{F \times d}{8} \right)$$

In case of a hollow shaft, the resultant stress,

$$\begin{aligned} \sigma_1 &= \frac{32M}{\pi (d_o)^3 (1 - k^4)} + \frac{4F}{\pi (d_o)^2 (1 - k^2)} \\ &= \frac{32}{\pi (d_o)^3 (1 - k^4)} \left[M + \frac{F d_o (1 + k^2)}{8} \right] = \frac{32M_1}{\pi (d_o)^3 (1 - k^4)} \end{aligned}$$

In case of long shafts (slender shafts) subjected to compressive loads, a factor known as **column factor** (α) must be introduced to take the column effect into account.

Therefore, Stress due to the compressive load,

$$\sigma_c = \frac{\alpha \times 4F}{\pi d^2}$$

or

$$= \frac{\alpha \times 4F}{\pi(d_o)^2 (1 - k^2)}$$

The value of column factor (α) for compressive loads* may be obtained from the following relation :

Column factor,

$$\alpha = \frac{1}{1 - 0.0044 (L/K)}$$

This expression is used when the slenderness ratio (L / K) is less than 115. When the slenderness ratio (L / K) is more than 115, then the value of column factor may be obtained from the following relation:

Column factor, α

$$\alpha = \frac{\sigma_y (L/K)^2}{C \pi^2 E}$$

Where L = Length of shaft between the bearings,

K = Least radius of gyration,

σ_y = Compressive yield point stress of shaft material, and

C = Coefficient in Euler's formula depending upon the end conditions.

The following are the different values of C depending upon the end conditions.

$C = 1$, for hinged ends,

$= 2.25$, for fixed ends,

$= 1.6$, for ends that are partly restrained as in bearings.

In general, for a hollow shaft subjected to fluctuating torsional and bending load, along with an axial load, the equations for equivalent twisting moment (T_e) and equivalent bending moment (M_e) may be written as

$$T_e = \sqrt{\left[K_m \times M + \frac{\alpha F d_o (1 + k^2)}{8} \right]^2 + (K_t \times T)^2}$$

$$= \frac{\pi}{16} \times \tau (d_o)^3 (1 - k^4)$$

$$M_e = \frac{1}{2} \left[K_m \times M + \frac{\alpha F d_o (1 + k^2)}{8} + \sqrt{\left\{ K_m \times M + \frac{\alpha F d_o (1 + k^2)}{8} \right\}^2 + (K_t \times T)^2} \right]$$

$$= \frac{\pi}{32} \times \sigma_b (d_o)^3 (1 - k^4)$$

It may be noted that for a solid shaft, $k = 0$ and $d_o = d$. When the shaft carries no axial load, then $F = 0$ and when the shaft carries axial tensile load, then $\alpha = 1$.

References:

1. Machine Design - V.Bandari .
2. Machine Design – R.S. Khurmi
3. Design Data hand Book - S MD Jalaludin.

Problem:

A hollow shaft is subjected to a maximum torque of 1.5 kN-m and a maximum bending moment of 3 kN-m. It is subjected, at the same time, to an axial load of 10 kN. Assume that the load is applied gradually and the ratio of the inner diameter to the outer diameter is 0.5. If the outer diameter of the shaft is 80 mm, find the shear stress induced in the shaft.

Solution. Given: $T = 1.5 \text{ kN-m} = 1.5 \times 10^3 \text{ N-m}$; $M = 3 \text{ kN-m} = 3 \times 10^3 \text{ N-m}$;

$F = 10 \text{ kN} = 10 \times 10^3 \text{ N}$; $k = d_i / d_o = 0.5$; $d_o = 80 \text{ mm} = 0.08 \text{ m}$

Let τ = Shear stress induced in the shaft.

Since the load is applied gradually, therefore from DDB, we find that $K_m = 1.5$; and $K_t = 1.0$

We know that the equivalent twisting moment for a hollow shaft,

$$\begin{aligned} T_e &= \sqrt{\left[K_m \times M + \frac{\alpha F d_o (1 + k^2)^2}{8} \right]^2 + (K_t \times T)^2} \\ &= \sqrt{\left[1.5 \times 3 \times 10^3 + \frac{1 \times 10 \times 10^3 \times 0.08 (1 + 0.5^2)^2}{8} \right]^2 + (1 \times 1.5 \times 10^3)^2} \\ &= \sqrt{(4500 + 125)^2 + (1500)^2} = 4862 \text{ N-m} = 4862 \times 10^3 \text{ N-mm} \end{aligned}$$

We also know that the equivalent twisting moment for a hollow shaft (T_e),

$$\begin{aligned} 4862 \times 10^3 &= \frac{\pi}{16} \times \tau (d_o)^3 (1 - k^4) = \frac{\pi}{16} \times \tau (80)^3 (1 - 0.5^4) = 94\,260 \tau \\ \therefore \tau &= 4862 \times 10^3 / 94\,260 = 51.6 \text{ N/mm}^2 = 51.6 \text{ MPa Ans.} \end{aligned}$$

Problem:

A hollow shaft of 0.5 m outside diameter and 0.3 m inside diameter is used to drive a propeller of a marine vessel. The shaft is mounted on bearings 6 metre apart and it transmits 5600 kW at 150 r.p.m. The maximum axial propeller thrust is 500 kN and the shaft weighs 70 kN.

Determine:

1. The maximum shear stress developed in the shaft, and
2. The angular twist between the bearings.

Solution. Given : $d_o = 0.5 \text{ m}$; $d_i = 0.3 \text{ m}$; $P = 5600 \text{ kW} = 5600 \times 10^3 \text{ W}$; $L = 6 \text{ m}$;
 $N = 150 \text{ r.p.m.}$; $F = 500 \text{ kN} = 500 \times 10^3 \text{ N}$; $W = 70 \text{ kN} = 70 \times 10^3 \text{ N}$

1. *Maximum shear stress developed in the shaft*

Let τ = Maximum shear stress developed in the shaft.

We know that the torque transmitted by the shaft,

$$T = \frac{P \times 60}{2\pi N} = \frac{5600 \times 10^3 \times 60}{2\pi \times 150} = 356\,460 \text{ N-m}$$

and the maximum bending moment,

$$M = \frac{W \times L}{8} = \frac{70 \times 10^3 \times 6}{8} = 52\,500 \text{ N-m}$$

Now let us find out the column factor α . We know that least radius of gyration,

$$\begin{aligned} K &= \sqrt{\frac{I}{A}} = \sqrt{\frac{\frac{\pi}{64} [(d_o)^4 - (d_i)^4]}{\frac{\pi}{4} [(d_o)^2 - (d_i)^2]}} \\ &= \sqrt{\frac{[(d_o)^2 + (d_i)^2][(d_o)^2 - (d_i)^2]}{16 [(d_o)^2 - (d_i)^2]}} \\ &= \frac{1}{4} \sqrt{(d_o)^2 + (d_i)^2} = \frac{1}{4} \sqrt{(0.5)^2 + (0.3)^2} = 0.1458 \text{ m} \end{aligned}$$

\therefore Slenderness ratio,

$$L / K = 6 / 0.1458 = 41.15$$

and column factor,

$$\begin{aligned} \alpha &= \frac{1}{1 - 0.0044 \left(\frac{L}{K}\right)} \quad \left(\because \frac{L}{K} < 115\right) \\ &= \frac{1}{1 - 0.0044 \times 41.15} = \frac{1}{1 - 0.18} = 1.22 \end{aligned}$$

Assuming that the load is applied gradually, therefore from Table 14.2, we find that

$$K_m = 1.5 \text{ and } K_t = 1.0$$

Also $k = d_i / d_o = 0.3 / 0.5 = 0.6$

We know that the equivalent twisting moment for a hollow shaft,

$$\begin{aligned} T_e &= \sqrt{\left[K_m \times M + \frac{\alpha F d_o (1 + k^2)}{8} \right]^2 + (K_t \times T)^2} \\ &= \sqrt{\left[1.5 \times 52\,500 + \frac{1.22 \times 500 \times 10^3 \times 0.5 (1 + 0.6^2)}{8} \right]^2 + (1 \times 356\,460)^2} \\ &= \sqrt{(78\,750 + 51\,850)^2 + (356\,460)^2} = 380 \times 10^3 \text{ N-m} \end{aligned}$$

We also know that the equivalent twisting moment for a hollow shaft (T_e),

$$380 \times 10^3 = \frac{\pi}{16} \times \tau (d_o)^3 (1 - k^4) = \frac{\pi}{16} \times \tau (0.5)^3 [1 - (0.6)^4] = 0.02 \tau$$

$\therefore \tau = 380 \times 10^3 / 0.02 = 19 \times 10^6 \text{ N/m}^2 = 19 \text{ MPa Ans.}$

2. *Angular twist between the bearings*

Let θ = Angular twist between the bearings in radians.

We know that the polar moment of inertia for a hollow shaft,

$$J = \frac{\pi}{32} [(d_o)^4 - (d_i)^4] = \frac{\pi}{32} [(0.5)^4 - (0.3)^4] = 0.00534 \text{ m}^4$$

From the torsion equation,

$$\frac{T}{J} = \frac{G \times \theta}{L}, \text{ we have}$$

$$\theta = \frac{T \times L}{G \times J} = \frac{356460 \times 6}{84 \times 10^9 \times 0.00534} = 0.0048 \text{ rad}$$

... (Taking $G = 84 \text{ GPa} = 84 \times 10^9 \text{ N/m}^2$)

$$= 0.0048 \times \frac{180}{\pi} = 0.275^\circ \text{ Ans.}$$

References:

1. Machine Design - V. Bandari .
2. Machine Design – R.S. Khurmi
3. Design Data hand Book - S MD Jalaludin.

Design of Shafts on the basis of Rigidity

Sometimes the shafts are to be designed on the basis of rigidity. We shall consider the following two types of rigidity.

1. Torsional rigidity. The torsional rigidity is important in the case of camshaft of an I.C. engine where the timing of the valves would be affected. The permissible amount of twist should not exceed 0.25° per metre length of such shafts. For line shafts or transmission shafts, deflections 2.5 to 3 degree per metre length may be used as limiting value. The widely used deflection for the shafts is limited to 1 degree in a length equal to twenty times the diameter of the shaft. The torsional deflection may be obtained by using the torsion equation,

$$\frac{T}{J} = \frac{G \cdot \theta}{L} \quad \text{or} \quad \theta = \frac{T \cdot L}{J \cdot G}$$

where θ = Torsional deflection or angle of twist in radians,

T = Twisting moment or torque on the shaft,

J = Polar moment of inertia of the cross-sectional area about the axis of rotation,

G = Modulus of rigidity for the shaft material, and

L = Length of the shaft.

2. Lateral rigidity. It is important in case of transmission shafting and shafts running at high speed, where small lateral deflection would cause huge out-of-balance forces. The lateral rigidity is also important for maintaining proper bearing clearances and for correct gear teeth alignment. If the shaft is of uniform cross-section, then the lateral deflection of a shaft may be obtained by using the deflection formulae as in Strength of Materials. But when the shaft is of variable cross-section, then the lateral deflection may be determined from the fundamental equation for the elastic curve of a beam, *i.e.*

$$\frac{d^2 y}{dx^2} = \frac{M}{EI}$$

BIS codes of Shafts

The standard sizes of transmission shafts are:

25 mm to 60 mm with 5 mm steps; 60 mm to 110 mm with 10 mm steps ; 110 mm to 140 mm with 15 mm steps ; and 140 mm to 500 mm with 20 mm steps. The standard length of the shafts are 5 m, 6 m and 7 m.

References:

1. Machine Design - V. Bandari .
2. Machine Design – R.S. Khurmi
3. Design Data hand Book - S MD Jalaludin.

Problem:

A steel spindle transmits 4 kW at 800 r.p.m. The angular deflection should not exceed 0.25° per metre of the spindle. If the modulus of rigidity for the material of the spindle is 84 GPa, find the diameter of the spindle and the shear stress induced in the spindle.

Solution. Given : $P = 4 \text{ kW} = 4000 \text{ W}$; $N = 800 \text{ r.p.m.}$; $\theta = 0.25^\circ = 0.25 \times \frac{\pi}{180} = 0.0044 \text{ rad}$;
 $L = 1 \text{ m} = 1000 \text{ mm}$; $G = 84 \text{ GPa} = 84 \times 10^9 \text{ N/m}^2 = 84 \times 10^3 \text{ N/mm}^2$

Diameter of the spindle

Let $d =$ Diameter of the spindle in mm.

We know that the torque transmitted by the spindle,

$$T = \frac{P \times 60}{2\pi N} = \frac{4000 \times 60}{2\pi \times 800} = 47.74 \text{ N-m} = 47\,740 \text{ N-mm}$$

We also know that $\frac{T}{J} = \frac{G \times \theta}{L}$ or $J = \frac{T \times l}{G \times \theta}$

or $\frac{\pi}{32} \times d^4 = \frac{47\,740 \times 1000}{84 \times 10^3 \times 0.0044} = 129\,167$

$\therefore d^4 = 129\,167 \times 32 / \pi = 1.3 \times 10^6$ or $d = 33.87$ say 35 mm Ans.

Shear stress induced in the spindle

Let $\tau =$ Shear stress induced in the spindle.

We know that the torque transmitted by the spindle (T),

$$47\,740 = \frac{\pi}{16} \times \tau \times d^3 = \frac{\pi}{16} \times \tau (35)^3 = 8420 \tau$$

$\therefore \tau = 47\,740 / 8420 = 5.67 \text{ N/mm}^2 = 5.67 \text{ MPa}$ Ans.

References:

1. Machine Design - V. Bandari .
2. Machine Design – R.S. Khurmi
3. Design Data hand Book - S MD Jalaludin.

Use of internal and external circlips, Gaskets and seals

References:

1. Machine Design - V.Bandari .
2. Machine Design – R.S. Khurmi
3. Design Data hand Book - S MD Jalaludin.

Problems:

Compare the weight, strength and stiffness of a hollow shaft of the same external diameter as that of solid shaft. The inside diameter of the hollow shaft being half the external diameter.

Both the shafts have the same material and length.

Solution. Given : $d_o = d$; $d_i = d_o / 2$ or $k = d_i / d_o = 1 / 2 = 0.5$

Comparison of weight

We know that weight of a hollow shaft,

$$\begin{aligned} W_H &= \text{Cross-sectional area} \times \text{Length} \times \text{Density} \\ &= \frac{\pi}{4} [(d_o)^2 - (d_i)^2] \times \text{Length} \times \text{Density} \end{aligned} \quad \dots(i)$$

and weight of the solid shaft,

$$W_S = \frac{\pi}{4} \times d^2 \times \text{Length} \times \text{Density} \quad \dots(ii)$$

Since both the shafts have the same material and length, therefore by dividing equation (i) by equation (ii), we get

$$\begin{aligned} \frac{W_H}{W_S} &= \frac{(d_o)^2 - (d_i)^2}{d^2} = \frac{(d_o)^2 - (d_i)^2}{(d_o)^2} \quad \dots(\because d = d_o) \\ &= 1 - \frac{(d_i)^2}{(d_o)^2} = 1 - k^2 = 1 - (0.5)^2 = 0.75 \text{ Ans.} \end{aligned}$$

Comparison of strength

We know that strength of the hollow shaft,

$$T_H = \frac{\pi}{16} \times \tau (d_o)^3 (1 - k^4) \quad \dots(iii)$$

and strength of the solid shaft,

$$T_S = \frac{\pi}{16} \times \tau \times d^3 \quad \dots(iv)$$

Dividing equation (iii) by equation (iv), we get

$$\begin{aligned} \frac{T_H}{T_S} &= \frac{(d_o)^3 (1 - k^4)}{d^3} = \frac{(d_o)^3 (1 - k^4)}{(d_o)^3} = 1 - k^4 \quad \dots(\because d = d_o) \\ &= 1 - (0.5)^4 = 0.9375 \text{ Ans.} \end{aligned}$$

Comparison of stiffness

We know that stiffness

$$= \frac{T}{\theta} = \frac{G \times J}{L}$$

\therefore Stiffness of a hollow shaft,

$$S_H = \frac{G}{L} \times \frac{\pi}{32} [(d_o)^4 - (d_i)^4] \quad \dots(v)$$

and stiffness of a solid shaft,

$$S_s = \frac{G}{L} \times \frac{\pi}{32} \times d^4 \quad \dots(vi)$$

Dividing equation (v) by equation (vi), we get

$$\begin{aligned} \frac{S_H}{S_s} &= \frac{(d_o)^4 - (d_i)^4}{d^4} = \frac{(d_o)^4 - (d_i)^4}{(d_o)^4} = 1 - \frac{(d_i)^4}{(d_o)^4} \quad \dots(\because d = d_o) \\ &= 1 - k^4 = 1 - (0.5)^4 = 0.9375 \text{ Ans.} \end{aligned}$$

References:

1. Machine Design - V. Bandari .
2. Machine Design – R.S. Khurmi
3. Design Data hand Book - S MD Jalaludin.

Shaft Coupling

Shafts are usually available up to 7 meters length due to inconvenience in transport. In order to have a greater length, it becomes necessary to join two or more pieces of the shaft by means of a coupling.

Shaft couplings are used in machinery for several purposes, the most common of which are the following:

1. To provide for the connection of shafts of units those are manufactured separately such as a motor and generator and to provide for disconnection for repairs or alternations.
2. To provide for misalignment of the shafts or to introduce mechanical flexibility.
3. To reduce the transmission of shock loads from one shaft to another.
4. To introduce protection against overloads.
5. It should have no projecting parts.

Types of Shafts Couplings

Shaft couplings are divided into two main groups as follows:

1. Rigid coupling. It is used to connect two shafts which are perfectly aligned. Following types of rigid coupling are important from the subject point of view:

- (a) Sleeve or muff coupling.
- (b) Clamp or split-muff or compression coupling, and
- (c) Flange coupling.

2. Flexible coupling. It is used to connect two shafts having both lateral and angular misalignment. Following types of flexible coupling are important from the subject point of view:

- (a) Bushed pin type coupling,
- (b) Universal coupling, and
- (c) Oldham coupling.

Sleeve or Muff-coupling

It is the simplest type of rigid coupling, made of cast iron. It consists of a hollow cylinder whose inner diameter is the same as that of the shaft. It is fitted over the ends of the two shafts by means of a gib head key, as shown in Fig. The power is transmitted from one shaft to the other shaft by means of a key and a sleeve. It is, therefore, necessary that all the elements must be strong enough to transmit the torque. The usual proportions of a cast iron sleeve coupling are as follows:

Outer diameter of the sleeve, $D = 2d + 13 \text{ mm}$

And length of the sleeve, $L = 3.5 d$

Where d is the diameter of the shaft.

In designing a sleeve or muff-coupling, the following procedure may be adopted.

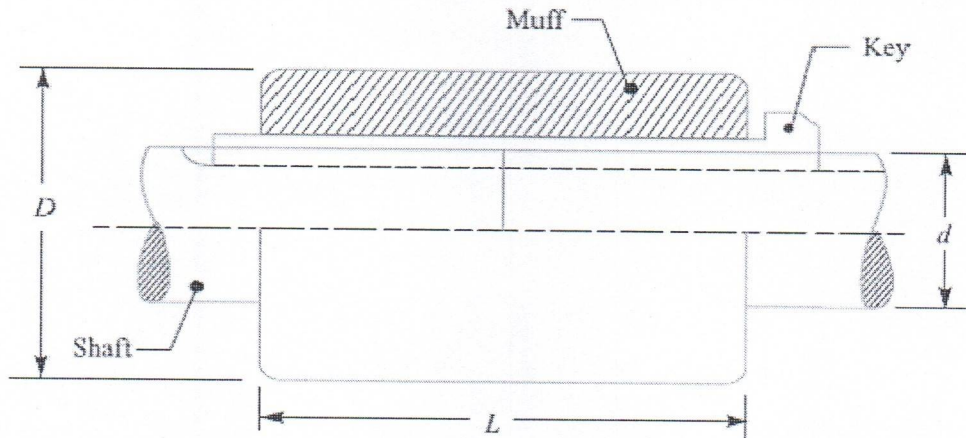

1. Design for sleeve

The sleeve is designed by considering it as a hollow shaft

Let T = Torque to be transmitted by the coupling, and

τ_c = Permissible shear stress for the material of the sleeve which is cast iron.

The safe value of shear stress for cast iron may be taken as 14 MPa.

We know that torque transmitted by a hollow section,

$$T = \frac{\pi}{16} \times \tau_c \left(\frac{D^4 - d^4}{D} \right) = \frac{\pi}{16} \times \tau_c \times D^3 (1 - k^4) \quad \dots (\because k = d/D)$$

From this expression, the induced shear stress in the sleeve may be checked.

2. Design for key

The key for the coupling may be designed in the similar way as discussed in Unit-5. The width and thickness of the coupling key is obtained from the proportions. The length of the coupling key is at least equal to the length of the sleeve (i.e. $3.5 d$). The coupling key is usually made into two parts so that the length of the key in each shaft,

$$l = \frac{L}{2} = \frac{3.5 d}{2}$$

After fixing the length of key in each shaft, the induced shearing and crushing stresses may be checked. We know that torque transmitted,

$$T = l \times w \times \tau \times \frac{d}{2} \quad \dots \text{(Considering shearing of the key)}$$

$$= l \times \frac{t}{2} \times \sigma_c \times \frac{d}{2} \quad \dots \text{(Considering crushing of the key)}$$

Note: The depth of the keyway in each of the shafts to be connected should be exactly the same and the diameters should also be same. If these conditions are not satisfied, then the key will be bedded on one shaft while in the other it will be loose. In order to prevent this, the key is made in two parts which may be driven from the same end for each shaft or they may be driven from opposite ends.

References:

1. Machine Design - V. Bandari .
2. Machine Design – R.S. Khurmi
3. Design Data hand Book - S MD Jalaludin.

Problem: Design and make a neat dimensioned sketch of a muff coupling which is used to connect two steel shafts transmitting 40 kW at 350 r.p.m. The material for the shafts and key is plain carbon steel for which allowable shear and crushing stresses may be taken as 40 MPa and 80 MPa respectively. The material for the muff is cast iron for which the allowable shear stress may be assumed as 15 MPa.

Solution.

Given: $P = 40 \text{ kW} = 40 \times 10^3 \text{ W}$; $N = 350 \text{ r.p.m.}$; $\tau_s = 40 \text{ MPa} = 40 \text{ N/mm}^2$; $\sigma_{cs} = 80 \text{ MPa} = 80 \text{ N/mm}^2$; $\sigma_c = 15 \text{ MPa} = 15 \text{ N/mm}^2$.

$$T = \frac{P \times 60}{2 \pi N} = \frac{40 \times 10^3 \times 60}{2 \pi \times 350} = 1100 \text{ N-m}$$

$$= 1100 \times 10^3 \text{ N-mm}$$

We also know that the torque transmitted (T),

$$1100 \times 10^3 = \frac{\pi}{16} \times \tau_s \times d^3 = \frac{\pi}{16} \times 40 \times d^3 = 7.86 d^3$$

$$\therefore d^3 = 1100 \times 10^3 / 7.86 = 140 \times 10^3 \text{ or } d = 52 \text{ say } 55 \text{ mm Ans.}$$

2. Design for sleeve

We know that outer diameter of the muff,

$$D = 2d + 13 \text{ mm} = 2 \times 55 + 13 = 123 \text{ say } 125 \text{ mm Ans.}$$

and length of the muff,

$$L = 3.5 d = 3.5 \times 55 = 192.5 \text{ say } 195 \text{ mm Ans.}$$

Let us now check the induced shear stress in the muff. Let τ_c be the induced shear stress in the muff which is made of cast iron. Since the muff is considered to be a hollow shaft, therefore the torque transmitted (T),

$$1100 \times 10^3 = \frac{\pi}{16} \times \tau_c \left(\frac{D^4 - d^4}{D} \right) = \frac{\pi}{16} \times \tau_c \left[\frac{(125)^4 - (55)^4}{125} \right]$$

$$= 370 \times 10^3 \tau_c$$

$$\therefore \tau_c = 1100 \times 10^3 / 370 \times 10^3 = 2.97 \text{ N/mm}^2$$

Since the induced shear stress in the muff (cast iron) is less than the permissible shear stress of 15 N/mm², therefore the design of muff is safe.

3. Design for key

From Design data Book, we find that for a shaft of 55 mm diameter,

$$\text{Width of key, } w = 18 \text{ mm Ans.}$$

Since the crushing stress for the key material is twice the shearing stress, therefore a square key may be used.

Then, Thickness of key, $t = w = 18 \text{ mm}$ **Ans.**

We know that length of key in each shaft,

$$l = L / 2 = 195 / 2 = 97.5 \text{ mm} \text{ **Ans.**}$$

Let us now check the induced shear and crushing stresses in the key. First of all, let us consider shearing of the key. We know that torque transmitted (T),

$$1100 \times 10^3 = l \times w \times \tau_s \times \frac{d}{2} = 97.5 \times 18 \times \tau_s \times \frac{55}{2} = 48.2 \times 10^3 \tau_s$$
$$\tau_s = 1100 \times 10^3 / 48.2 \times 10^3 = 22.8 \text{ N/mm}^2$$

Now considering crushing of the key. We know that torque transmitted (T),

$$1100 \times 10^3 = l \times \frac{t}{2} \times \sigma_{cs} \times \frac{d}{2} = 97.5 \times \frac{18}{2} \times \sigma_{cs} \times \frac{55}{2} = 24.1 \times 10^3 \sigma_{cs}$$
$$\sigma_{cs} = 1100 \times 10^3 / 24.1 \times 10^3 = 45.6 \text{ N/mm}^2$$

Since the induced shear and crushing stresses are less than the permissible stresses, therefore the design of key is safe.

References:

1. Machine Design - V. Bandari.
2. Machine Design - R.S. Khurmi
3. Design Data hand Book - S MD Jalaludin.

Clamp or Compression Coupling or split muff coupling

It is also known as **split muff coupling**. In this case, the muff or sleeve is made into two halves and are bolted together as shown in Fig. The halves of the muff are made of cast iron. The shaft ends are made to a butt each other and a single key is fitted directly in the keyways of both the shafts. One-half of the muff is fixed from below and the other half is placed from above. Both the halves are held together by means of mild steel studs or bolts and nuts. The number of bolts may be two, four or six. The nuts are recessed into the bodies of the muff castings. This coupling may be used for heavy duty and moderate speeds. The advantage of this coupling is that the position of the shafts need not be changed for assembling or disassembling of the coupling. The usual proportions of the muff for the clamp or compression coupling are:

$$\text{Diameter of the muff or sleeve, } D = 2d + 13 \text{ mm}$$

$$\text{Length of the muff or sleeve, } L = 3.5 d$$

Where d = Diameter of the shaft.

In the clamp or compression coupling, the power is transmitted from one shaft to the other by means of key and the friction between the muff and shaft. In designing this type of coupling, the following procedure may be adopted.

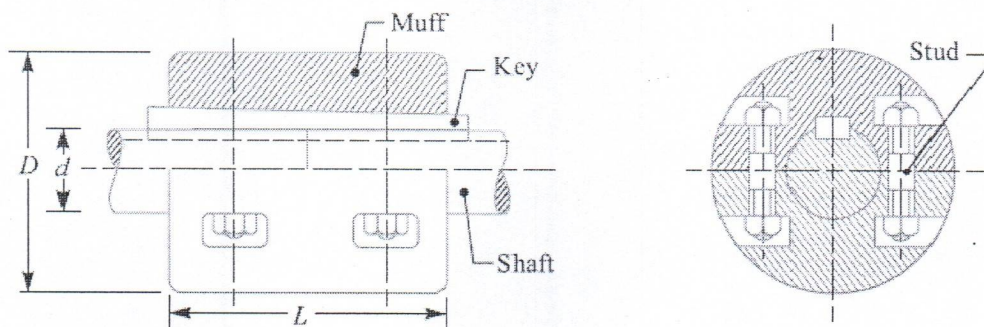

1. Design of muff and key

The muff and key are designed in the similar way as discussed in muff coupling.

2. Design of clamping bolts

Let T = Torque transmitted by the shaft,

d = Diameter of shaft,

d_b = Root or effective diameter of bolt,

n = Number of bolts,

σ_t = Permissible tensile stress for bolt material,

μ = Coefficient of friction between the muff and shaft, and

L = Length of muff.

We know that the force exerted by each bolt

$$= \frac{\pi}{4} (d_b)^2 \sigma_t$$

Then, Force exerted by the bolts on each side of the shaft

$$= \frac{\pi}{4} (d_b)^2 \sigma_t \times \frac{n}{2}$$

Let p be the pressure on the shaft and the muff surface due to the force, then for uniform pressure distribution over the surface,

$$p = \frac{\text{Force}}{\text{Projected area}} = \frac{\frac{\pi}{4} (d_b)^2 \sigma_t \times \frac{n}{2}}{\frac{1}{2} L \times d}$$

Then, Frictional force between each shaft and muff,

$$\begin{aligned} F &= \mu \times \text{pressure} \times \text{area} = \mu \times p \times \frac{1}{2} \times \pi d \times L \\ &= \mu \times \frac{\frac{\pi}{4} (d_b)^2 \sigma_t \times \frac{n}{2}}{\frac{1}{2} L \times d} \times \frac{1}{2} \pi d \times L \\ &= \mu \times \frac{\pi}{4} (d_b)^2 \sigma_t \times \frac{n}{2} \times \pi = \mu \times \frac{\pi^2}{8} (d_b)^2 \sigma_t \times n \end{aligned}$$

And the torque that can be transmitted by the coupling,

$$T = F \times \frac{d}{2} = \mu \times \frac{\pi^2}{8} (d_b)^2 \sigma_t \times n \times \frac{d}{2} = \frac{\pi^2}{16} \times \mu (d_b)^2 \sigma_t \times n \times d$$

From this relation, the root diameter of the bolt (d_b) may be evaluated.

Flange Coupling

A flange coupling usually applies to a coupling having two separate cast iron flanges. Each flange is mounted on the shaft end and keyed to it. The faces are turned up at right angle to the axis of the shaft. One of the flanges has a projected portion and the other flange has a corresponding recess. This helps to bring the shafts into line and to maintain alignment. The two flanges are coupled together by means of bolts and nuts. The flange coupling is adapted to heavy loads and hence it is used on large shafting.

The flange couplings are of the following three types:

1. Unprotected type flange coupling. In an unprotected type flange coupling, as shown in Fig.1, each shaft is keyed to the boss of a flange with a counter sunk key and the flanges are coupled together by means of bolts. Generally, three, four or six bolts are used. The keys are staggered at right angle along the circumference of the shafts in order to divide the weakening effect caused by keyways.

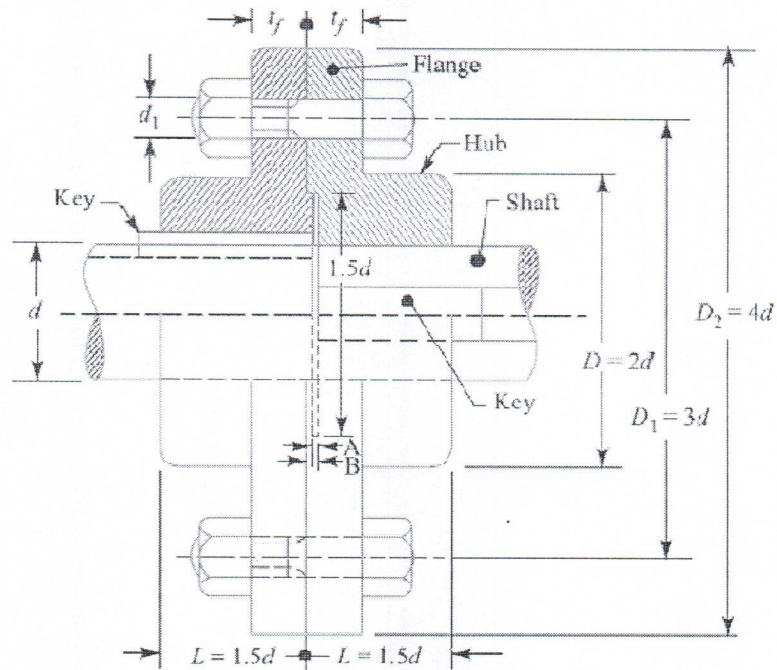

Fig.1 Unprotected Type Flange Coupling.

The usual proportions for an unprotected type cast iron flange couplings, as shown in Fig.1, are as follows:

If d is the diameter of the shaft or inner diameter of the hub, then Outside diameter of hub,

$$D = 2d$$

$$\text{Length of hub, } L = 1.5d$$

$$\text{Pitch circle diameter of bolts, } D_1 = 3d$$

Outside diameter of flange,

$$D_2 = D_1 + (D_1 - D) = 2D_1 - D = 4d$$

Thickness of flange, $t_f = 0.5d$

$$\text{Number of bolts} = 3, \text{ for } d \text{ upto } 40 \text{ mm}$$

$$= 4, \text{ for } d \text{ upto } 100 \text{ mm}$$

$$= 6, \text{ for } d \text{ upto } 180 \text{ mm}$$

2. Protected type flange coupling. In a protected type flange coupling, as shown in Fig.2, the protruding bolts and nuts are protected by flanges on the two halves of the coupling, in order to avoid danger to the workman. The thickness of the protective circumferential flange (t_p) is taken as $0.25 d$. The other proportions of the coupling are same as for unprotected type flange coupling.

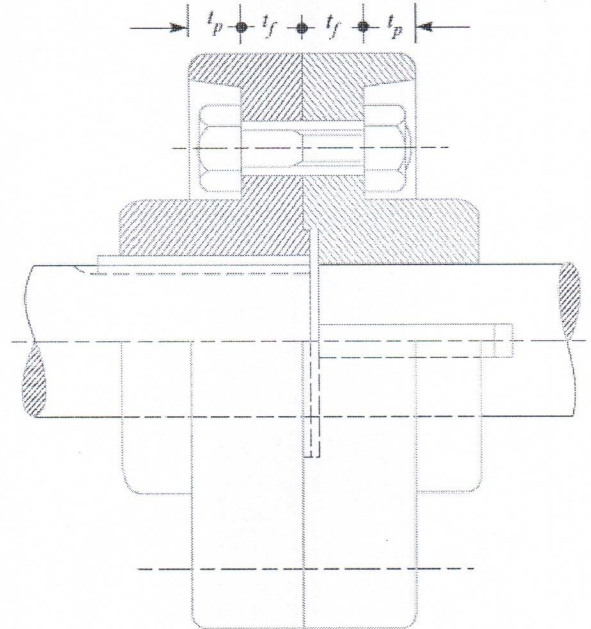

Fig.2. Protected Type Flange Coupling.

3. Marine type flange coupling. In a marine type flange coupling, the flanges are forged integral with the shafts as shown in Fig.3.

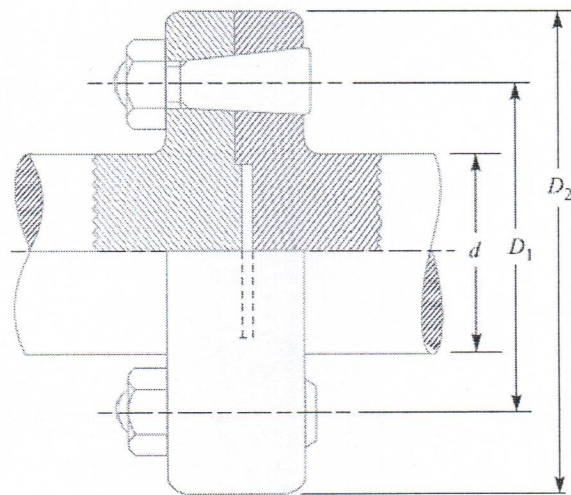

Fig.3. Solid Flange Coupling or Marine Type flange coupling.

The flanges are held together by means of tapered headless bolts, numbering from four to twelve depending upon the diameter of shaft. The other proportions for the marine type flange coupling are taken as follows:

Thickness of flange = $d / 3$

Taper of bolt = 1 in 20 to 1 in 40

Pitch circle diameter of bolts, $D_1 = 1.6 d$

Outside diameter of flange, $D_2 = 2.2 d$

Design of Flange Coupling

Consider a flange coupling as shown in Fig.1 and Fig.2.

Let d = Diameter of shaft or inner diameter of hub,

D = Outer diameter of hub,

D_1 = Nominal or outside diameter of bolt,

D_1 = Diameter of bolt circle,

n = Number of bolts,

t_f = Thickness of flange,

τ_s , τ_b and τ_k = Allowable shear stress for shaft, bolt and key material respectively

τ_c = Allowable shear stress for the flange material i.e. cast iron,

σ_{cb} , and σ_{ck} = Allowable crushing stress for bolt and key material respectively.

The flange coupling is designed as discussed below:

1. Design for hub

The hub is designed by considering it as a hollow shaft, transmitting the same torque (T) as that of a solid shaft.

$$T = \frac{\pi}{16} \times \tau_c \left(\frac{D^4 - d^4}{D} \right)$$

The outer diameter of hub is usually taken as twice the diameter of shaft. Therefore from the above relation, the induced shearing stress in the hub may be checked.

The length of hub (L) is taken as $1.5 d$.

2. Design for key

The key is designed with usual proportions and then checked for shearing and crushing stresses. The material of key is usually the same as that of shaft. The length of key is taken equal to the length of hub.

3. Design for flange

The flange at the junction of the hub is under shear while transmitting the torque. Therefore, the torque transmitted,

$$T = \text{Circumference of hub} \times \text{Thickness of flange} \times \text{Shear stress of flange} \times \text{Radius of hub}$$

$$= \pi D \times t_f \times \tau_c \times \frac{D}{2} = \frac{\pi D^2}{2} \times \tau_c \times t_f$$

The thickness of flange is usually taken as half the diameter of shaft. Therefore from the above relation, the induced shearing stress in the flange may be checked.

4. Design for bolts

The bolts are subjected to shear stress due to the torque transmitted. The number of bolts (n) depends upon the diameter of shaft and the pitch circle diameter of bolts (D_1) is taken as 3 d.

We know that

Load on each bolt

$$= \frac{\pi}{4} (d_1)^2 \tau_b$$

Then, Total load on all the bolts

$$= \frac{\pi}{4} (d_1)^2 \tau_b \times n$$

And torque transmitted,

$$T = \frac{\pi}{4} (d_1)^2 \tau_b \times n \times \frac{D_1}{2}$$

From this equation, the diameter of bolt (d_1) may be obtained. Now the diameter of bolt may be checked in crushing.

We know that area resisting crushing of all the bolts = $n \times d_1 \times t_f$

And crushing strength of all the bolts = $(n \times d_1 \times t_f) \sigma_{cb}$

Torque,

$$T = (n \times d_1 \times t_f \times \sigma_{cb}) \frac{D_1}{2}$$

From this equation, the induced crushing stress in the bolts may be checked.

References:

1. Machine Design - V. Bandari .
2. Machine Design – R.S. Khurmi
3. Design Data hand Book - S MD Jalaludin.

Problem: Design a cast iron protective type flange coupling to transmit 15 kW at 900 r.p.m. from an electric motor to a compressor. The service factor may be assumed as 1.35. The following permissible stresses may be used :

Shear stress for shaft, bolt and key material = 40 MPa

Crushing stress for bolt and key = 80 MPa

Shear stress for cast iron = 8 MPa

Draw a neat sketch of the coupling.

Solution. Given: $P = 15 \text{ kW} = 15 \times 10^3 \text{ W}$; $N = 900 \text{ r.p.m.}$; Service factor = 1.35 ; $\tau_s = \tau_b = \tau_k = 40 \text{ MPa} = 40 \text{ N/mm}^2$; $\sigma_{cb} = \sigma_{ck} = 80 \text{ MPa} = 80 \text{ N/mm}^2$; $\tau_c = 8 \text{ MPa} = 8 \text{ N/mm}^2$.

The protective type flange coupling is designed as discussed below:

1. Design for hub

First of all, let us find the diameter of the shaft (d). We know that the torque transmitted by the shaft,

$$T = \frac{P \times 60}{2 \pi N} = \frac{15 \times 10^3 \times 60}{2 \pi \times 900} = 159.13 \text{ N-m}$$

Since the service factor is 1.35, therefore the maximum torque transmitted by the shaft, $T_{\max} = 1.35 \times 159.13 = 215 \text{ N-m} = 215 \times 10^3 \text{ N-mm}$

We know that the torque transmitted by the shaft (T),

$$215 \times 10^3 = \frac{\pi}{16} \times \tau_s \times d^3 = \frac{\pi}{16} \times 40 \times d^3 = 7.86 d^3$$

$$d^3 = 215 \times 10^3 / 7.86 = 27.4 \times 10^3 \quad \text{or} \quad d = 30.1 \text{ say } 35 \text{ mm Ans.}$$

We know that outer diameter of the hub,

$$D = 2d = 2 \times 35 = 70 \text{ mm Ans.}$$

And length of hub, $L = 1.5 d = 1.5 \times 35 = 52.5 \text{ mm Ans.}$

Let us now check the induced shear stress for the hub material which is cast iron. Considering the hub as a hollow shaft. We know that the maximum torque transmitted (T_{\max}).

$$215 \times 10^3 = \frac{\pi}{16} \times \tau_c \left[\frac{D^4 - d^4}{D} \right] = \frac{\pi}{16} \times \tau_c \left[\frac{(70)^4 - (35)^4}{70} \right] = 63 \ 147 \ \tau_c$$

$$\text{Then, } \tau_c = 215 \times 10^3 / 63 \ 147 = 3.4 \text{ N/mm}^2 = 3.4 \text{ MPa}$$

Since the induced shear stress for the hub material (i.e. cast iron) is less than the permissible value of 8 MPa, therefore the design of hub is safe.

2. Design for key

Since the crushing stress for the key material is twice its shear stress (i.e. $\sigma_{ck} = 2\tau_k$), therefore a square key may be used. From DDB, we find that for a shaft of 35 mm diameter,

Width of key, $w = 12$ mm Ans.

And thickness of key, $t = w = 12$ mm Ans.

The length of key (l) is taken equal to the length of hub.

Then, $l = L = 52.5$ mm Ans.

Let us now check the induced stresses in the key by considering it in shearing and crushing.

Considering the key in shearing. We know that the maximum torque transmitted (T_{max}),

$$215 \times 10^3 = l \times w \times \tau_k \times \frac{d}{2} = 52.5 \times 12 \times \tau_k \times \frac{35}{2} = 11\,025 \tau_k$$

Then, $\tau_k = 215 \times 10^3 / 11\,025 = 19.5$ N/mm² = 19.5 MPa

Considering the key in crushing. We know that the maximum torque transmitted (T_{max}),

$$215 \times 10^3 = l \times \frac{t}{2} \times \sigma_{ck} \times \frac{d}{2} = 52.5 \times \frac{12}{2} \times \sigma_{ck} \times \frac{35}{2} = 5512.5 \sigma_{ck}$$

$\sigma_{ck} = 215 \times 10^3 / 5512.5 = 39$ N/mm² = 39 MPa.

Since the induced shear and crushing stresses in the key are less than the permissible stresses, therefore the design for key is safe.

3. Design for flange

The thickness of flange (t_f) is taken as 0.5 d.

Then, $t_f = 0.5 d = 0.5 \times 35 = 17.5$ mm Ans.

Let us now check the induced shearing stress in the flange by considering the flange at the junction of the hub in shear.

We know that the maximum torque transmitted (T_{max}),

$$215 \times 10^3 = \frac{\pi D^2}{2} \times \tau_c \times t_f = \frac{\pi (70)^2}{2} \times \tau_c \times 17.5 = 134\,713 \tau_c$$

$\tau_c = 215 \times 10^3 / 134\,713 = 1.6$ N/mm² = 1.6 MPa

Since the induced shear stress in the flange is less than 8 MPa, therefore the design of flange is safe.

4. Design for bolts

Let d_1 = Nominal diameter of bolts.

Since the diameter of the shaft is 35 mm, therefore let us take the number of bolts,

$n = 3$ and pitch circle diameter of bolts,

$D_1 = 3d = 3 \times 35 = 105$ mm

The bolts are subjected to shear stress due to the torque transmitted. We know that the maximum torque transmitted (T_{\max}),

$$215 \times 10^3 = \frac{\pi}{4} (d_1)^2 \tau_b \times n \times \frac{D_1}{2} = \frac{\pi}{4} (d_1)^2 40 \times 3 \times \frac{105}{2} = 4950 (d_1)^2$$

$$(d_1)^2 = 215 \times 10^3 / 4950 = 43.43 \text{ or } d_1 = 6.6 \text{ mm}$$

Assuming coarse threads, the nearest standard size of bolt is M 8. Ans.

Other proportions of the flange are taken as follows:

Outer diameter of the flange,

$$D_2 = 4 d = 4 \times 35 = 140 \text{ mm Ans.}$$

Thickness of the protective circumferential flange,

$$t_p = 0.25 d = 0.25 \times 35 = 8.75 \text{ say } 10 \text{ mm Ans.}$$

References:

1. Machine Design - V. Bandari .
2. Machine Design – R.S. Khurmi
3. Design Data hand Book - S MD Jalaludin.

Flexible Coupling:

We have already discussed that a flexible coupling is used to join the abutting ends of shafts when they are not in exact alignment. In the case of a direct coupled drive from a prime mover to an electric generator, we should have four bearings at a comparatively close distance. In such a case and in many others, as in a direct electric drive from an electric motor to a machine tool, a flexible coupling is used so as to permit an axial misalignment of the shaft without undue absorption of the power which the shaft are transmitting.

Bushed-pin Flexible Coupling

A bushed-pin flexible coupling, as shown in Fig., is a modification of the rigid type of flange coupling. The coupling bolts are known as pins.

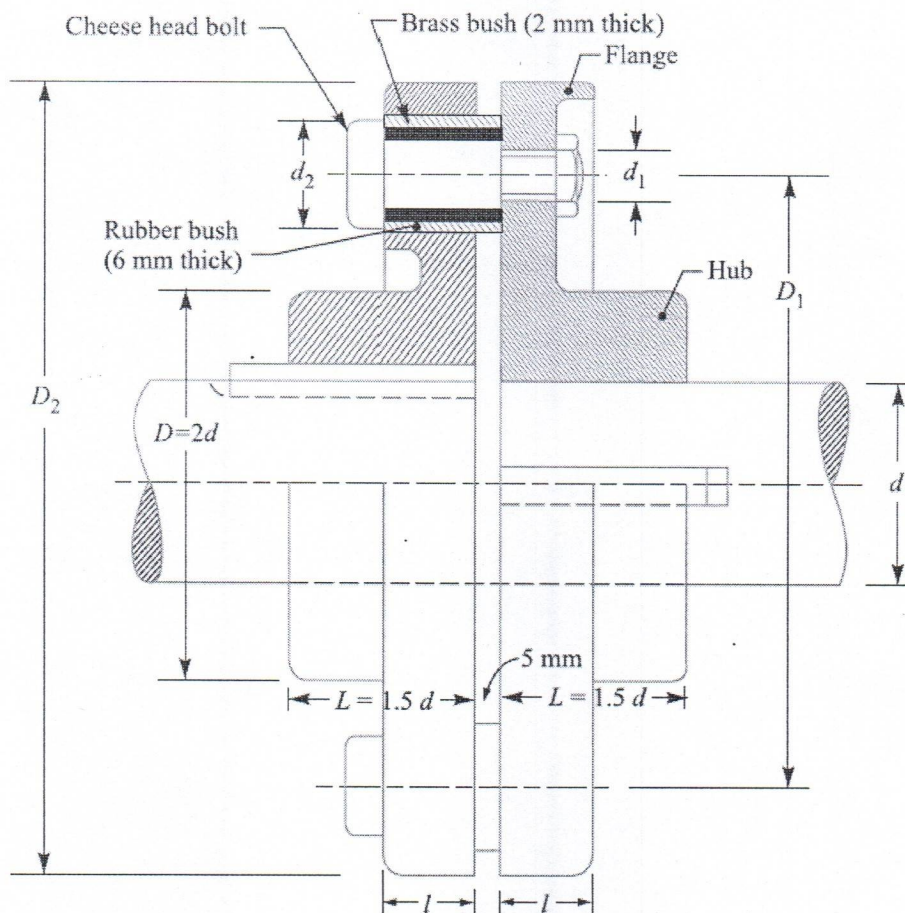

The rubber or leather bushes are used over the pins. The two halves of the coupling are dissimilar in construction. A clearance of 5 mm is left between the face of the two halves of the coupling. There is no rigid connection between them and the drive takes place through the medium of the compressible rubber or leather bushes.

In designing the bushed-pin flexible coupling, the proportions of the rigid type flange coupling are modified. The main modification is to reduce the bearing pressure on the rubber or leather bushes and it should not exceed 0.5 N/mm². In order to keep the low bearing pressure, the pitch circle diameter and the pin size is increased.

Let l = Length of bush in the flange,

D_2 = Diameter of bush,

p_b = Bearing pressure on the bush or pin,

n = Number of pins, and

D_1 = Diameter of pitch circle of the pins.

We know that bearing load acting on each pin,

$$W = p_b \times d_2 \times l$$

Then, Total bearing load on the bush or pins

$$= W \times n = p_b \times d_2 \times l \times n$$

And the torque transmitted by the coupling,

$$T = W \times n \left(\frac{D_1}{2} \right) = p_b \times d_2 \times l \times n \left(\frac{D_1}{2} \right)$$

The threaded portion of the pin in the right hand flange should be a tapping fit in the coupling hole to avoid bending stresses.

The threaded length of the pin should be as small as possible so that the direct shear stress can be taken by the unthreaded neck.

Direct shear stress due to pure torsion in the coupling halves,

$$\tau = \frac{W}{\frac{\pi}{4} (d_1)^2}$$

Since the pin and the rubber or leather bush is not rigidly held in the left hand flange, therefore the tangential load (W) at the enlarged portion will exert a bending action

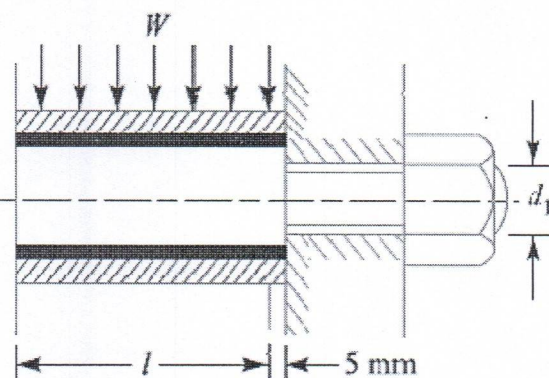

on the pin as shown in Fig. The bush portion of the pin acts as a cantilever beam of length l .

Assuming a uniform distribution of the load W along the bush, the maximum bending moment on the pin,

$$M = W \left(\frac{l}{2} + 5 \text{ mm} \right)$$

We know that bending stress,

$$\sigma = \frac{M}{Z} = \frac{W \left(\frac{l}{2} + 5 \text{ mm} \right)}{\frac{\pi}{32} (d_1)^3}$$

Since the pin is subjected to bending and shear stresses, therefore the design must be checked either for the maximum principal stress or maximum shear stress by the following relations:

Maximum principal stress

$$= \frac{1}{2} \left[\sigma + \sqrt{\sigma^2 + 4\tau^2} \right]$$

and the maximum shear stress on the pin

$$= \frac{1}{2} \sqrt{\sigma^2 + 4\tau^2}$$

The value of maximum principal stress varies from 28 to 42 MPa.

Note: After designing the pins and rubber bush, the hub, key and flange may be designed in the similar way as discussed for flange coupling.

References:

1. Machine Design - V. Bandari .
2. Machine Design – R.S. Khurmi
3. Design Data hand Book - S MD Jalaludin.

Problem:

Design a bushed-pin type of flexible coupling to connect a pump shaft to a motor shaft transmitting 32 kW at 960 r.p.m. The overall torque is 20 percent more than mean torque. The material properties are as follows:

- (a) The allowable shear and crushing stress for shaft and key material is 40 MPa and 80 MPa respectively.
- (b) The allowable shear stress for cast iron is 15 MPa.
- (c) The allowable bearing pressure for rubber bush is 0.8 N/mm².
- (d) The material of the pin is same as that of shaft and key.

Draw neat sketch of the coupling.

Solution. Given: $P = 32 \text{ kW} = 32 \times 10^3 \text{ W}$; $N = 960 \text{ r.p.m.}$; $T_{\max} = 1.2 T_{\text{mean}}$; $\tau_s = \tau_k = 40 \text{ MPa} = 40 \text{ N/mm}^2$; $\sigma_{cs} = \sigma_{ck} = 80 \text{ MPa} = 80 \text{ N/mm}^2$; $\tau_c = 15 \text{ MPa} = 15 \text{ N/mm}^2$; $p_b = 0.8 \text{ N/mm}^2$.

1. Design for pins and rubber bush

$$T_{\text{mean}} = \frac{P \times 60}{2\pi N} = \frac{32 \times 10^3 \times 60}{2\pi \times 960} = 318.3 \text{ N-m}$$

$$T_{\text{max}} = 1.2 T_{\text{mean}} = 1.2 \times 318.3 = 382 \text{ N-m} = 382 \times 10^3 \text{ N-mm}$$

$$382 \times 10^3 = \frac{\pi}{16} \times \tau_s \times d^3 = \frac{\pi}{16} \times 40 \times d^3 = 7.86 d^3$$

$$d^3 = 382 \times 10^3 / 7.86 = 48.6 \times 10^3 \text{ or } d = 36.5 \text{ say } 40 \text{ mm}$$

$$d_1 = \frac{0.5d}{\sqrt{n}} = \frac{0.5 \times 40}{\sqrt{6}} = 8.2 \text{ mm}$$

In order to allow for the bending stress induced due to the compressibility of the rubber bush, the diameter of the pin (d_1) may be taken as 20 mm. Ans.

The length of the pin of least diameter i.e. $d_1 = 20 \text{ mm}$ is threaded and secured in the right hand coupling half by a standard nut and washer. The enlarged portion of the pin which is in the left hand coupling half is made of 24 mm diameter. On the enlarged portion, a brass bush of thickness 2 mm is pressed. A brass bush carries a rubber bush. Assume the thickness of rubber bush as 6 mm.

So, Overall diameter of rubber bush,

$$d_2 = 24 + 2 \times 2 + 2 \times 6 = 40 \text{ mm} \quad \text{Ans.}$$

and diameter of the pitch circle of the pins,

$$D_1 = 2d + d_2 + 2 \times 6 = 2 \times 40 + 40 + 12 = 132 \text{ mm} \quad \text{Ans.}$$

Let l = Length of the bush in the flange.

We know that the bearing load acting on each pin,

$$W = p_b \times d_2 \times l = 0.8 \times 40 \times l = 32l \text{ N}$$

And the maximum torque transmitted by the coupling (T_{\max}),

$$382 \times 10^3 = W \times n \times \frac{D_1}{2} = 32l \times 6 \times \frac{132}{2} = 12672l$$

$$l = 382 \times 103 / 12672 = 30.1 \text{ say } 32 \text{ mm}$$

And $W = 32l = 32 \times 32 = 1024 \text{ N}$

So, Direct stress due to pure torsion in the coupling halves,

$$\tau = \frac{W}{\frac{\pi}{4}(d_1)^2} = \frac{1024}{\frac{\pi}{4}(20)^2} = 3.26 \text{ N/mm}^2$$

Since the pin and the rubber bush are not rigidly held in the left hand flange, therefore the tangential load (W) at the enlarged portion will exert a bending action on the pin. Assuming a uniform distribution of load (W) along the bush, the maximum bending moment on the pin,

$$M = W \left(\frac{l}{2} + 5 \right) = 1024 \left(\frac{32}{2} + 5 \right) = 21504 \text{ N-mm}$$

$$Z = \frac{\pi}{32}(d_1)^3 = \frac{\pi}{32}(20)^3 = 785.5 \text{ mm}^3$$

$$\sigma = \frac{M}{Z} = \frac{21504}{785.5} = 27.4 \text{ N/mm}^2$$

Maximum principal stress

$$\begin{aligned} &= \frac{1}{2} \left[\sigma + \sqrt{\sigma^2 + 4\tau^2} \right] = \frac{1}{2} \left[27.4 + \sqrt{(27.4)^2 + 4(3.26)^2} \right] \\ &= 13.7 + 14.1 = 27.8 \text{ N/mm}^2 \end{aligned}$$

And maximum shear stress

$$= \frac{1}{2} \left[\sqrt{\sigma^2 + 4\tau^2} \right] = \frac{1}{2} \left[\sqrt{(27.4)^2 + 4(3.26)^2} \right] = 14.1 \text{ N/mm}^2$$

Since the maximum principal stress and maximum shear stress are within limits, therefore the design is safe.

2. Design for hub

We know that the outer diameter of the hub,

$$D = 2 d = 2 \times 40 = 80 \text{ mm}$$

And length of hub, $L = 1.5 d = 1.5 \times 40 = 60 \text{ mm}$

Let us now check the induced shear stress for the hub material which is cast iron. Considering the hub as a hollow shaft. We know that the maximum torque transmitted (T_{\max}),

$$382 \times 10^3 = \frac{\pi}{16} \times \tau_c \left[\frac{D^4 - d^4}{D} \right] = \frac{\pi}{16} \times \tau_c \left[\frac{(80)^4 - (40)^4}{80} \right] = 94.26 \times 10^3 \tau_c$$

$$\tau_c = 382 \times 10^3 / 94.26 \times 10^3 = 4.05 \text{ N/mm}^2 = 4.05 \text{ MPa}$$

Since the induced shear stress for the hub material (i.e. cast iron) is less than the permissible value of 15 MPa, therefore the design of hub is safe.

3. Design for key

Since the crushing stress for the key material is twice its shear stress (i.e. $\sigma_{ck} = 2 \tau_k$), therefore a square key may be used. From Table 13.1, we find that for a shaft of 40 mm diameter,

Width of key, $w = 14 \text{ mm}$ Ans.

and thickness of key, $t = w = 14 \text{ mm}$ Ans.

The length of key (L) is taken equal to the length of hub, i.e.

$$L = 1.5 d = 1.5 \times 40 = 60 \text{ mm}$$

Let us now check the induced stresses in the key by considering it in shearing and crushing.

Considering the key in shearing. We know that the maximum torque transmitted (T_{\max}),

$$382 \times 10^3 = L \times w \times \tau_k \times \frac{d}{2} = 60 \times 14 \times \tau_k \times \frac{40}{2} = 16800 \tau_k$$

$$\tau_k = 382 \times 10^3 / 16800 = 22.74 \text{ N/mm}^2 = 22.74 \text{ MPa}$$

Considering the key in crushing. We know that the maximum torque transmitted (T_{\max}),

$$382 \times 10^3 = L \times \frac{t}{2} \times \sigma_{ck} \times \frac{d}{2} = 60 \times \frac{14}{2} \times \sigma_{ck} \times \frac{40}{2} = 8400 \sigma_{ck}$$

$$\sigma_{ck} = 382 \times 10^3 / 8400 = 45.48 \text{ N/mm}^2 = 45.48 \text{ MPa}$$

Since the induced shear and crushing stress in the key are less than the permissible stresses of 40 MPa and 80 MPa respectively, therefore the design for key is safe.

4. Design for flange

The thickness of flange (t_f) is taken as 0.5 d.

$$t_f = 0.5 d = 0.5 \times 40 = 20 \text{ mm}$$

Let us now check the induced shear stress in the flange by considering the flange at the junction of the hub in shear.

We know that the maximum torque transmitted (T_{\max}),

$$382 \times 10^3 = \frac{\pi D^2}{2} \times \tau_c \times t_f = \frac{\pi (80)^2}{2} \times \tau_c \times 20 = 201 \times 10^3 \tau_c$$

$$\tau_c = 382 \times 10^3 / 201 \times 10^3 = 1.9 \text{ N/mm}^2 = 1.9 \text{ MPa}$$

Since the induced shear stress in the flange of cast iron is less than 15 MPa, therefore the design of flange is safe.

References:

1. Machine Design - V. Bandari .
2. Machine Design – R.S. Khurmi
3. Design Data hand Book - S MD Jalaludin.

Problem:

Design a cast iron protective type flange coupling to transmit 15 kW at 900 r.p.m. from an electric motor to a compressor. The service factor may be assumed as 1.35. The following permissible stresses may be used:

Shear stress for shaft, bolt and key material = 40 MPa

Crushing stress for bolt and key = 80 MPa

Shear stress for cast iron = 8 MPa

Draw a neat sketch of the coupling.

Solution. Given: $P = 15 \text{ kW} = 15 \times 10^3 \text{ W}$; $N = 900 \text{ r.p.m.}$; Service factor = 1.35; $\tau_s = \tau_b = \tau_k = 40 \text{ MPa} = 40 \text{ N/mm}^2$; $\sigma_{cb} = \sigma_{ck} = 80 \text{ MPa} = 80 \text{ N/mm}^2$; $\tau_c = 8 \text{ MPa} = 8 \text{ N/mm}^2$.

The protective type flange coupling is designed as discussed below:

1. Design for hub

First of all, let us find the diameter of the shaft (d). We know that the torque transmitted by the shaft,

$$T = \frac{P \times 60}{2 \pi N} = \frac{15 \times 10^3 \times 60}{2 \pi \times 900} = 159.13 \text{ N-m}$$

Since the service factor is 1.35, therefore the maximum torque transmitted by the shaft, $T_{\max} = 1.35 \times 159.13 = 215 \text{ N-m} = 215 \times 10^3 \text{ N-mm}$

We know that the torque transmitted by the shaft (T),

$$215 \times 10^3 = \frac{\pi}{16} \times \tau_s \times d^3 = \frac{\pi}{16} \times 40 \times d^3 = 7.86 d^3$$

$$d^3 = 215 \times 10^3 / 7.86 = 27.4 \times 10^3 \quad \text{or} \quad d = 30.1 \text{ say } 35 \text{ mm Ans.}$$

We know that outer diameter of the hub,

$$D = 2d = 2 \times 35 = 70 \text{ mm Ans.}$$

And length of hub, $L = 1.5 d = 1.5 \times 35 = 52.5 \text{ mm Ans.}$

Let us now check the induced shear stress for the hub material which is cast iron. Considering the hub as a hollow shaft. We know that the maximum torque transmitted (T_{\max}).

$$215 \times 10^3 = \frac{\pi}{16} \times \tau_c \left[\frac{D^4 - d^4}{D} \right] = \frac{\pi}{16} \times \tau_c \left[\frac{(70)^4 - (35)^4}{70} \right] = 63\,147 \tau_c$$

$$\text{Then, } \tau_c = 215 \times 10^3 / 63\,147 = 3.4 \text{ N/mm}^2 = 3.4 \text{ MPa}$$

Since the induced shear stress for the hub material (i.e. cast iron) is less than the permissible value of 8 MPa, therefore the design of hub is safe.

2. Design for key

Since the crushing stress for the key material is twice its shear stress (i.e. $\sigma_{ck} = 2\tau_k$), therefore a square key may be used. From DDB, we find that for a shaft of 35 mm diameter,

Width of key, $w = 12$ mm Ans.

And thickness of key, $t = w = 12$ mm Ans.

The length of key (l) is taken equal to the length of hub.

Then, $l = L = 52.5$ mm Ans.

Let us now check the induced stresses in the key by considering it in shearing and crushing.

Considering the key in shearing. We know that the maximum torque transmitted (T_{max}),

$$215 \times 10^3 = l \times w \times \tau_k \times \frac{d}{2} = 52.5 \times 12 \times \tau_k \times \frac{35}{2} = 11\,025 \tau_k$$

Then, $\tau_k = 215 \times 10^3 / 11\,025 = 19.5$ N/mm² = 19.5 MPa

Considering the key in crushing. We know that the maximum torque transmitted (T_{max}),

$$215 \times 10^3 = l \times \frac{t}{2} \times \sigma_{ck} \times \frac{d}{2} = 52.5 \times \frac{12}{2} \times \sigma_{ck} \times \frac{35}{2} = 5512.5 \sigma_{ck}$$

$\sigma_{ck} = 215 \times 10^3 / 5512.5 = 39$ N/mm² = 39 MPa.

Since the induced shear and crushing stresses in the key are less than the permissible stresses, therefore the design for key is safe.

3. Design for flange

The thickness of flange (t_f) is taken as 0.5 d .

Then, $t_f = 0.5 d = 0.5 \times 35 = 17.5$ mm Ans.

Let us now check the induced shearing stress in the flange by considering the flange at the junction of the hub in shear.

We know that the maximum torque transmitted (T_{max}),

$$215 \times 10^3 = \frac{\pi D^2}{2} \times \tau_c \times t_f = \frac{\pi (70)^2}{2} \times \tau_c \times 17.5 = 134\,713 \tau_c$$

$\tau_c = 215 \times 10^3 / 134\,713 = 1.6$ N/mm² = 1.6 MPa

Since the induced shear stress in the flange is less than 8 MPa, therefore the design of flange is safe.

4. Design for bolts

Let d_1 = Nominal diameter of bolts.

Since the diameter of the shaft is 35 mm, therefore let us take the number of bolts,

$n = 3$ and pitch circle diameter of bolts,

$$D_1 = 3d = 3 \times 35 = 105 \text{ mm}$$

The bolts are subjected to shear stress due to the torque transmitted. We know that the maximum torque transmitted (T_{\max}),

$$215 \times 10^3 = \frac{\pi}{4} (d_1)^2 \tau_b \times n \times \frac{D_1}{2} = \frac{\pi}{4} (d_1)^2 40 \times 3 \times \frac{105}{2} = 4950 (d_1)^2$$
$$(d_1)^2 = 215 \times 103/4950 = 43.43 \text{ or } d_1 = 6.6 \text{ mm}$$

Assuming coarse threads, the nearest standard size of bolt is M 8. Ans.

Other proportions of the flange are taken as follows:

Outer diameter of the flange,

$$D_2 = 4d = 4 \times 35 = 140 \text{ mm} \quad \text{Ans.}$$

Thickness of the protective circumferential flange,

$$t_p = 0.25d = 0.25 \times 35 = 8.75 \text{ say } 10 \text{ mm} \quad \text{Ans.}$$

References:

1. Machine Design - V. Bandari .
2. Machine Design – R.S. Khurmi
3. Design Data hand Book - S MD Jalaludin.

Problem:

Two 35 mm shafts are connected by a flanged coupling. The flanges are fitted with 6 bolts on 125 mm bolt circle. The shafts transmit a torque of 800 N-m at 350 r.p.m. For the safe stresses mentioned below, calculate 1. Diameter of bolts; 2. Thickness of flanges; 3. Key dimensions ; 4. Hub length; and 5. Power transmitted. Safe shear stress for shaft material = 63 MPa Safe stress for bolt material = 56 MPa Safe stress for cast iron coupling = 10 MPa Safe stress for key material = 46 MPa

Solution. Given: $d = 35$ mm; $n = 6$; $D_1 = 125$ mm; $T = 800$ N-m = 800×10^3 N-mm; $N = 350$ r.p.m.; $\tau_s = 63$ MPa = 63 N/mm²; $\tau_b = 56$ MPa = 56 N/mm²; $\tau_c = 10$ MPa = 10 N/mm²; $\tau_k = 46$ MPa = 46 N/mm².

1. Diameter of bolts

Let d_1 = Nominal or outside diameter of bolt. We know that the torque transmitted (T),

$$800 \times 10^3 = \frac{\pi}{4} (d_1)^2 \tau_b \times n \times \frac{D_1}{2} = \frac{\pi}{4} (d_1)^2 56 \times 6 \times \frac{125}{2} = 16\,495 (d_1)^2$$
$$(d_1)^2 = 800 \times 10^3 / 16\,495 = 48.5 \text{ or } d_1 = 6.96 \text{ say } 8 \text{ mm} \quad \text{Ans.}$$

2. Thickness of flanges

Let t_f = Thickness of flanges.

We know that the torque transmitted (T),

$$800 \times 10^3 = \frac{\pi D^2}{2} \times \tau_c \times t_f = \frac{\pi (2 \times 35)^2}{2} \times 10 \times t_f = 76\,980 t_f \quad \dots (\because D = 2d)$$
$$t_f = 800 \times 10^3 / 76\,980 = 10.4 \text{ say } 12 \text{ mm} \quad \text{Ans.}$$

3. Key dimensions

From Table 13.1, we find that the proportions of key for a 35 mm diameter shaft are:

$$\text{Width of key, } w = 12 \text{ mm} \quad \text{Ans.}$$

$$\text{And thickness of key, } t = 8 \text{ mm} \quad \text{Ans.}$$

The length of key (l) is taken equal to the length of hub (L).

$$l = L = 1.5 d = 1.5 \times 35 = 52.5 \text{ mm}$$

Let us now check the induced shear stress in the key. We know that the torque transmitted (T),

$$800 \times 10^3 = l \times w \times \tau_k \times \frac{d}{2} = 52.5 \times 12 \times \tau_k \times \frac{35}{2} = 11\,025 \tau_k$$

$$\tau_k = 800 \times 10^3 / 11\,025 = 72.5 \text{ N/mm}^2$$

Since the induced shear stress in the key is more than the given safe stress (46 MPa), therefore let us find the length of key by substituting the value of $\tau_k = 46 \text{ MPa}$ in the above equation, i.e.

$$800 \times 10^3 = l \times 12 \times 46 \times \frac{35}{2} = 9660 l$$

$$l = 800 \times 10^3 / 9660 = 82.8 \text{ say } 85 \text{ mm Ans.}$$

4. Hub length

Since the length of key is taken equal to the length of hub, therefore we shall take hub length,

$$L = l = 85 \text{ mm Ans.}$$

5. Power transmitted

We know that the power transmitted,

$$P = \frac{T \times 2\pi N}{60} = \frac{800 \times 2\pi \times 350}{60} = 29\,325 \text{ W} = 29.325 \text{ kW Ans.}$$

Problem:

The shaft and the flange of a marine engine are to be designed for flange coupling, in which the flange is forged on the end of the shaft. The following particulars are to be considered in the design:

Power of the engine = 3 MW

Speed of the engine = 100 r.p.m.

Permissible shear stress in bolts and shaft = 60 MPa

Number of bolts used = 8

Pitch circle diameter of bolts = 1.6 × Diameter of shaft

Find: 1. diameter of shaft; 2. diameter of bolts; 3. thickness of flange; and 4. diameter of flange.

Solution. Given: $P = 3 \text{ MW} = 3 \times 10^6 \text{ W}$; $N = 100 \text{ r.p.m.}$; $\tau_b = \tau_s = 60 \text{ MPa} = 60 \text{ N/mm}^2$; $n = 8$; $D_1 = 1.6 d$

1. Diameter of shaft

Let $d = \text{Diameter of shaft.}$

We know that the torque transmitted by the shaft,

$$T = \frac{P \times 60}{2\pi N} = \frac{3 \times 10^6 \times 60}{2\pi \times 100} = 286 \times 10^3 \text{ N-m} = 286 \times 10^6 \text{ N-mm}$$

We also know that torque transmitted by the shaft (T),

$$286 \times 10^6 = \frac{\pi}{16} \times \tau_s \times d^3 = \frac{\pi}{16} \times 60 \times d^3 = 11.78 d^3$$

$$d_3 = 286 \times 10^6 / 11.78 = 24.3 \times 10^6$$

$$\text{or } d = 2.89 \times 10^2 = 289 \text{ say } 300 \text{ mm Ans.}$$

2. Diameter of bolts

Let d_1 = Nominal diameter of bolts.

The bolts are subjected to shear stress due to the torque transmitted. We know that torque transmitted (T),

$$286 \times 10^6 = \frac{\pi}{4} (d_1)^2 \tau_b \times n \times \frac{D_1}{2} = \frac{\pi}{4} \times (d_1)^2 \times 60 \times 8 \times \frac{1.6 \times 300}{2}$$

$$= 90\,490 (d_1)^2 \dots (\text{Since } D_1 = 1.6 d)$$

$$\text{So, } (d_1)^2 = 286 \times 10^6 / 90\,490 = 3160 \text{ or } d_1 = 56.2 \text{ mm}$$

Assuming coarse threads, the standard diameter of the bolt is 60 mm (M 60). The taper on the bolt may be taken from 1 in 20 to 1 in 40. **Ans.**

3. Thickness of flange

The thickness of flange (t_f) is taken as $d/3$.

$$\text{So, } t_f = d/3 = 300/3 = 100 \text{ mm Ans.}$$

Let us now check the induced shear stress in the flange by considering the flange at the junction of the shaft in shear. We know that the torque transmitted (T),

$$286 \times 10^6 = \frac{\pi d^2}{2} \times \tau_s \times t_f = \frac{\pi (300)^2}{2} \times \tau_s \times 100 = 14.14 \times 10^6 \tau_s$$

$$\tau_s = 286 \times 10^6 / 14.14 \times 10^6 = 20.2 \text{ N/mm}^2 = 20.2 \text{ MPa}$$

Since the induced shear stress in the *flange is less than the permissible shear stress of 60 MPa, therefore the thickness of flange ($t_f = 100$ mm) is safe.

4. Diameter of flange

The diameter of flange (D_2) is taken as 2.2 d.

$$\text{So, } D_2 = 2.2 d = 2.2 \times 300 = 660 \text{ mm Ans.}$$

References:

1. Machine Design - V. Bandari .

2. Machine Design – R.S. Khurmi

3. Design Data hand Book - S MD Jalaludin.