

Unit I

Simple Stress and Strains

Simple Stresses and Strains

Define the strength, Mechanical properties of commonly used engineering materials. Identify the nature and effect of tensile, compressive and shear forces. Define the terms stress, strain State Hook's law, define the terms Poisson's ratio and elastic moduli. Draw the typical stress - strain curve for ductile and brittle materials under tension indicating salient points on it. Mention the significance of Factor of Safety. Write down the relation between elastic constants $E, N, K, & 1/m$. Compute stress and strain values in bodies of uniform section and of composite section under the influence of normal forces. Calculate thermal stresses, in bodies of uniform section and composite sections. Compute changes in axial, lateral and volumetric dimensions of bodies of uniform sections under the action of normal forces.

Introduction to Mechanics of Materials

Strength of Materials or Mechanics of Materials is a branch of applied mechanics that deals with the behaviour of deformable solid bodies subjected to various types of loadings. While studying Engineering Mechanics it is assumed that all bodies are either rigid or point particles. In this course on Strength of Materials, the bodies are considered deformable and subjected to failure or breakage. The focus is more on the internal effects in a body due to externally applied loads. This helps in determining the safe loads on a structure and is essential in the safe design of all types of structures like airplanes, antennas, buildings, bridges, ships, automobiles, spacecrafts, etc. This course forms the foundation for most engineering disciplines.

Mechanical Properties of Engineering Materials

The mechanical properties of a material are those which affect the mechanical strength and ability of material to be engineered into a suitable shape or application. Some of the typical mechanical properties of a material are as follows.

Strength: The *strength of a material* is its ability to withstand an applied load without failure. Failure is the state of the material in which it is no longer able to bear the applied load.

Elasticity: The property of a material by the virtue of which it returns to its original shape and size after removal of the applied load is called elasticity. The materials which follow such behaviour are said to be elastic.

Plasticity: The property of a material by the virtue of which it undergoes permanent deformations, even after removal of the applied loads is known as plasticity. The materials which are not elastic are said to be plastic.

Ductility: Ductility is a property which allows the material to be deformed longitudinally to a reduced section under tensile stress. Ductility is often categorized by the ability of material to get stretched into a wire by pulling or drawing. This mechanical property is also an aspect of plasticity of material.

Brittleness: Brittleness means lack of ductility. A brittle material cannot be deformed longitudinally to a reduced section under tensile stress. It fails or breaks without significant deformation and without any warning. It is an undesirable property from structural engineering point of view.

Malleability: Malleability is property of the material which allows the material to get easily deformed into any shape under compressive stress. Malleability is often categorized by the ability of material to be formed in the form of a thin sheet by hammering or rolling. This mechanical property is an aspect of plasticity of material.

Toughness: Toughness is the ability of material to absorb energy and gets plastically deformed without fracturing. Its numerical value is determined by the amount of energy per unit volume.

Its unit is Joule/ m³. Value of toughness of a material can be determined by stress-strain characteristics of material. For good toughness material should have good strength as well as ductility. For example: brittle materials, having good strength but limited ductility are not tough enough. Conversely, materials having good ductility but low strength are also not tough enough. Therefore, to be tough, material should be capable to withstand with both high stress and strain.

Hardness: Hardness is the ability of a material to resist indentation or surface abrasion. Hardness measures are categorized into scratch hardness, indentation hardness and rebound hardness.

Concept of Stress and Strain

Stress: There are no engineering materials which are perfectly rigid and hence when material is subjected to external loads, it undergoes deformation. While undergoing deformation the particles of the material exert a resisting force. When this resisting force becomes equal to the applied load, an equilibrium condition takes place and deformation stops. This internal resistance is called stress. Internal resistance per unit area is called intensity of stress (σ). Its SI unit is N/m² or Pascal (Pa). It is common in engineering practices to specify the units of stress in N/mm² or MPa.

Consider a uniform cross-section bar under an axial load P . Let us pass an imaginary plane perpendicular to the bar along the middle so that the bar is divided into two halves. What holds one part of the bar with the other part is the internal molecular forces, which arise due to the external load P . In other words, due to the external load there is an internal resistive force that is generated which holds the body together. This internal resistive force per unit area is defined as stress. If A is the area of cross-section of the bar, then the average stress (σ) on a given cross-sectional area (A) of a material, which is subjected to load P , is given by

$$\sigma = \frac{P}{A}$$

Saint Venant's principle:

We must note that the above expression for stress is the average value of the stress over the entire surface. In reality, the stress varies along the cross-section, particularly at the ends of the bar carrying axial load, as shown in Figure 1.

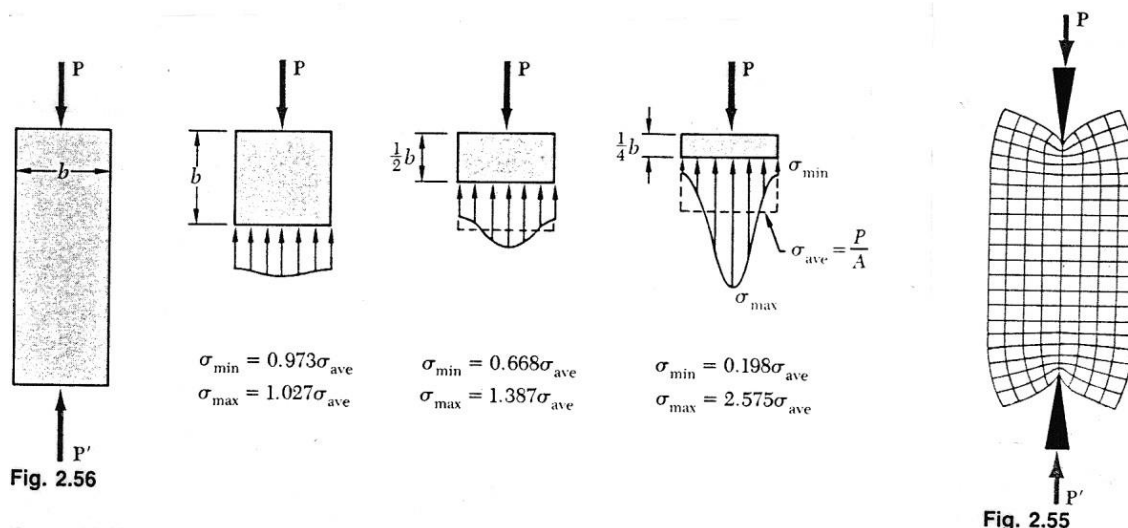
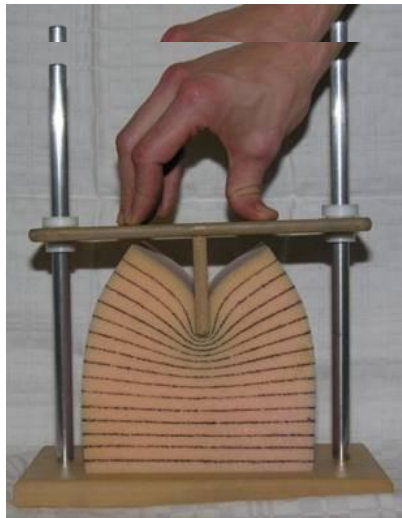

Figure 1. Illustration of Stress Concentration and St. Venant's Principle

The stresses are highly concentrated in the immediate vicinity of the point of application of the load and reduce in magnitude as we move away from it along the cross-section. However, as we move away from the end of the bar towards the middle portion of the bar, the stress distribution becomes more uniform throughout the cross-section. Thus, away from the ends, the cross-sections can be assumed to have uniform stress, as given in equation (1). This is called the St. Venant's principle, which is more formally stated as:

The stresses in a deformable solid body at a point sufficiently remote from the point of application of the load depend only on the static resultant of the loads and not on the local distribution of the loads.



Figures (1) and (2) depict this principle.

Types of Stress

A) Normal/Direct Stress

1. Tensile Stress

The stress induced in a body, when subjected to two equal and opposite pull, as a result of which there is an increase in length, is known as tensile stress. Tensile stress tends to elongate the body.

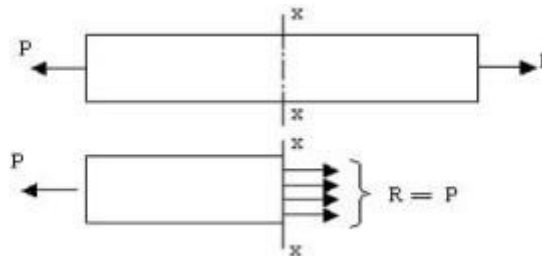

Figure 3. A bar subjected to tensile (axial) loading

Consider a uniform bar of cross-section area A subjected to an axial force P . The stress at any section, $x-x$, normal to the line of action of tensile force P is shown in the figure. The internal resistance R at $x-x$ is equal to applied force P .

$$\text{Tensile Stress} = \frac{\text{Resisting Force (R)}}{\text{Cross Sectional Area (A)}} = \frac{P}{A}$$

Under tensile stress, bar suffer stretching or elongation.

2. Compressive Stress

The stress induced in a body, when subjected to two equal and opposites pushes, as a result of which there is decrease in length, is known as compressive stress.

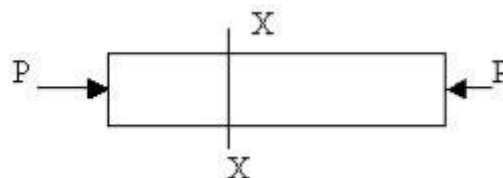

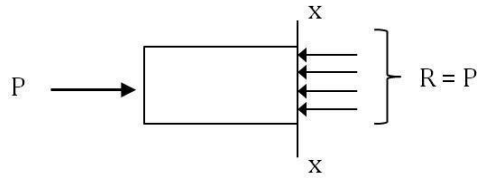

Figure 4. A bar subjected to compressive (axial) loading

Consider a uniform bar of cross-section area A subjected to an axial compressive load P. The stress at any section x-x normal to the line of action of compressive force P is shown in the figure. The internal resistance R at x-x is equal to applied load P.

$$\text{Compressive Stress} = \frac{\text{Resisting Force (R)}}{\text{Cross Sectional Area (A)}} = \frac{P}{A}$$

Under compressive stress, bar suffers shortening.

Tensile Stresses are considered positive and compressive stresses are considered negative, as per general numerical sign convention for stresses.

B) Shear/Tangential Stress

A shear stress, symbolized by the Greek letter tau, τ , results when a member is subjected to a force that is parallel or tangent to the surface. The average shear stress in the member is obtained by dividing the magnitude of the resultant shear force V by the cross sectional area A. Shear stress is:

$$\text{Shear Stress, } \tau = \frac{\text{Shear Force (V)}}{\text{Cross Sectional Area (A)}} = \frac{V}{A}$$

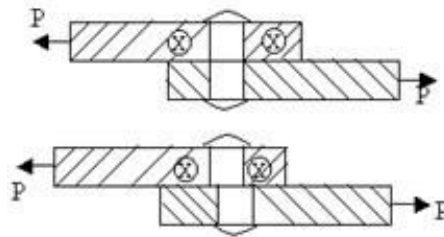

Figure 5. A rivet subjected to shear force

Consider a section of rivet is subjected to equal and opposite force P acting in a direction parallel to the resisting section. Such forces which are equal and opposite and act tangentially across the section, causing sliding of particles one over the other, are called shearing forces and corresponding stress induced in the rivet is called shearing stress.

Consider another example of a Clevis Joint as shown in Figure 6

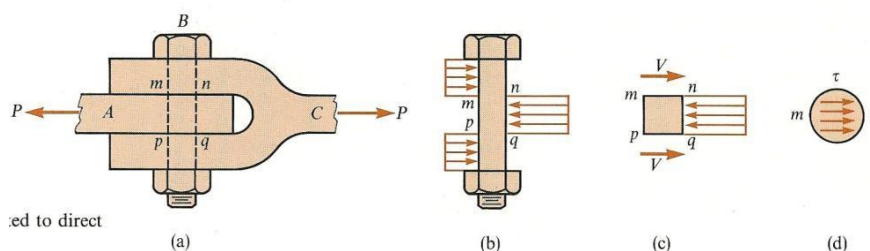

Figure 6. A rivet in a Clevis Joint subjected to shear

a) Typical clevis joint b) Free body diagram of bolt c) Free body of section mm d) Shear stresses on section mn

It should be noted that the distributions of shear stresses is not uniform across the cross section. Shear stress will be highest near the center of the section and become zero at the edge. Direct or simple shear arises in the design of bolts, pins, rivets, keys, welds and glued joints.

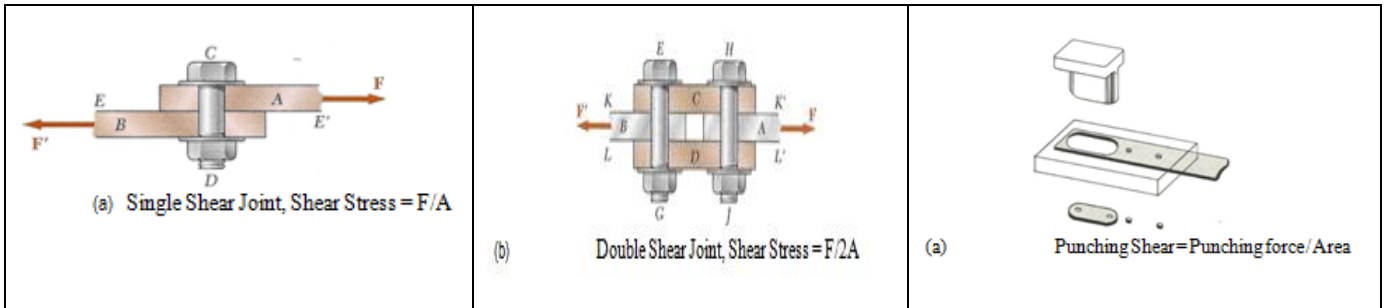

Figure 7. Examples of Single, Double and Punching Shear

Concept of complementary shear stresses

Consider an element ABCD from a material subjected to shearing stress (τ) on a faces AB and CD as shown in the Figure 8 (a), due to equal and opposite forces F applied onto the two faces. Since the element is in static equilibrium, it is not just the horizontal forces that are in balance, but the moment also has to be balanced. This unbalanced moment is balanced by counter couple on the two perpendicular faces BC and AD, as shown in figure 8 (b).

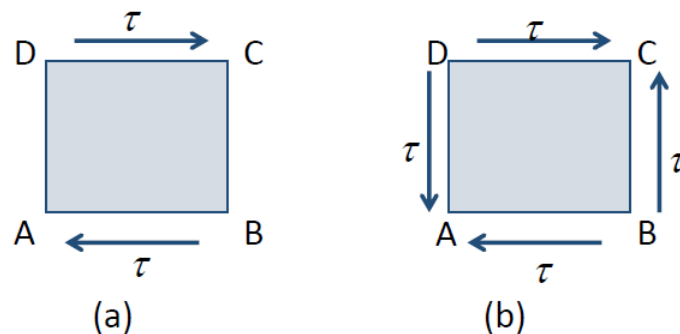

Figure 8. (a) Unbalanced Moments due to Shear

(b) Complementary Shear exists for Moment balance

To understand the existence of complementary shear, consider the following illustration. Suppose that a material block is divided into a number of rectangular elements, as shown by the full lines of Figure 9.

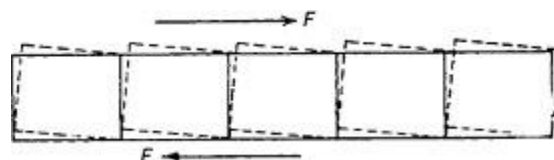

Figure 9. Illustration of existence of complimentary shear

Under the actions of the shearing forces F , which together constitute a couple, the elements will tend to take up the positions shown by the dotted lines in Figure 9. It will be seen that there is a tendency for the vertical faces of the elements to slide over each other. Actually the ends of the elements do not slide over each other in this way, but the tendency to so do shows that the shearing stress in horizontal planes is accompanied by shearing stresses in vertical planes perpendicular to the applied shearing forces. This is true of all cases of shearing action a given shearing stress acting on one plane is always

accompanied by a complementary shearing stress on planes at right angles to the plane on which the given stress acts.

C) Bearing Stress

A bearing stress, symbolized by the Greek letter sigma σ_b , is a compressive normal stress that occurs on the surface of contact between two interacting members. The average normal stress in the member is obtained by dividing the magnitude of the bearing force F by the area of interest. Bearing stress for the situation in Figure 10 is

$$\sigma_b = \frac{\text{Punching Force}}{\text{Contact Area}} = \frac{P}{A_b} = \frac{P}{td}$$

Bolts, pins and rivets create bearing stresses along the surface of contact.

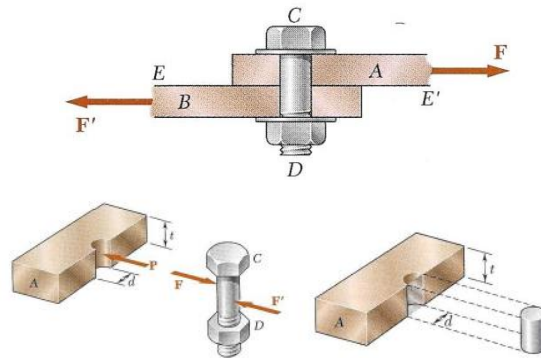

Figure 10. Demonstration of Bearing Stress

Strain

Strain is a measure of deformation produced by the application of external force. It is the ratio of change in length to original length. It is denoted by Epsilon (ϵ). Strain is dimensionless. Strain in direction of applied load is known as linear or longitudinal strain.

$$\text{Strain } (\epsilon) = \frac{\text{Change of length } (\delta l)}{\text{Original length } (l)}$$

Types of Strain

1. Tensile strain

Let initial length of bar before applied load be l , when tensile load P is applied. Let the bar be elongated by δl .

$$\text{Tensile strain } (\epsilon) = \frac{\text{Extension in length } (\delta l)}{\text{Original length } (l)}$$



Figure 11. Tensile Strain

2. Compressive strain

Let initial length of bar before applied load be l , when compressive load P is applied. Its length gets decrease by δl .

$$\text{Compressive Strain } (\epsilon) = \frac{\text{Shortening in length } (\delta l)}{\text{Original length } (l)}$$

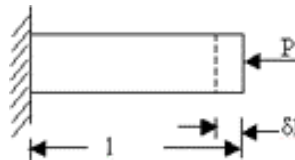

Figure 12. Compressive Strain

3. Shear Strain (γ)

To get a proper definition of strain, it is important to understand the concept of complementary shear stresses in a material as discussed in the previous section.

Consider again the element ABCD from a material subjected to shearing stress (τ) on a faces AB and CD as shown in Figure 13 (a). We may assume that the deformation occurs as shown in Figure 13 (b). However, this is possible only when the base AB is glued to the bottom. If the element ABCD is the portion of the material as shown in Figure 14 (a) subject to shear forces, then its deformation will be as shown in Figure 14 (b). This deformation is more common case of shear deformation in materials.

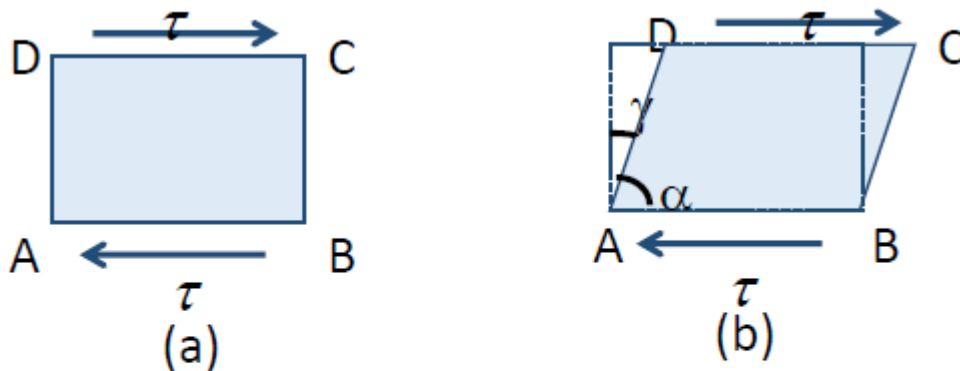

Figure 13. Shear deformation when edge AB is glued at the bottom

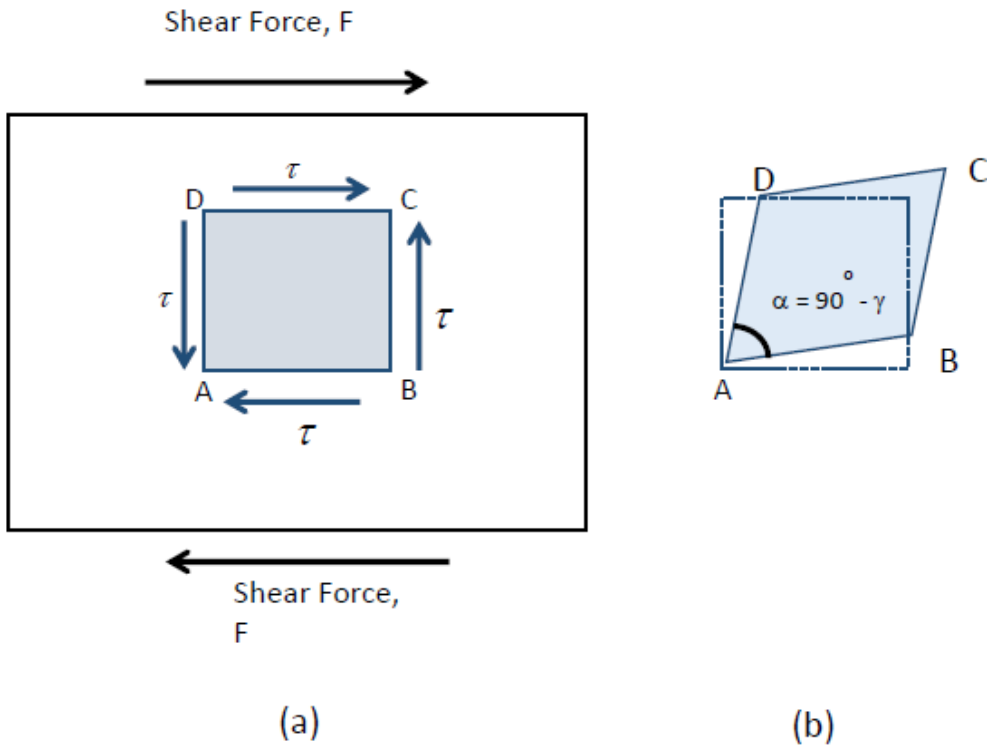

Figure 14. Shear deformation in a plane in a general case

The shear strain is best defined as the change in the angle between the originally perpendicular edges of the rectangular element of the material, upon application of the shear stress. Original angle between AB and AD is 90° . After deformation it is α . Thus, shear strain is defined as

$$\gamma = 90^\circ - \alpha$$

This definition is valid for both cases as shown in Figures 13 and 14.

Hooke's Law

Within elastic limit or more accurately up to the proportional limit of the material, the stress is directly proportional to strain.

For normal stress, the Hooke's law gives $\sigma = E \epsilon$ or

Where σ = Axial/Normal Stress

ϵ = Axial/Normal Strain

E is known as Modulus of Elasticity or Young's Modulus or Elastic Modulus.

Young's Modulus (E) =

For shear stress, the Hooke's law gives $\tau \propto \gamma$ or

$$\tau = G \gamma$$

Where τ = Shear Stress

γ = Shear Strain

G is known as Modulus of Rigidity or Shear Modulus.

$$\text{Modulus of Rigidity (G)} = \frac{\text{Shear Stress } (\tau)}{\text{Shear Strain } (\gamma)}$$

Simple Tension Test for Mild Steel Specimen on Universal Testing Machine (UTM)

To study the behaviour of ductile materials in tension, a standard mild steel specimen is used for tensile test on universal testing machine (UTM).

- On the UTM more than one test can be performed like Tension, Compression, Bending and Shear etc.
- The end of specimens is gripped in UTM and one of the grips is moved apart by hydraulic jack or system, thus exerting tensile load on the specimen.
- The load applied is indicated on dial and the extension in the initial stages is measured by using an extensometer fixed on specimen itself and later stages by scale fixed on machine.
- Almost all machines are provided with an autographic recorder which is directly records the load vs deformation curve (or) stress vs strain curve.
- To fix the extensometer on specimen, two points are marked on a portion of specimen. The distance between these points over which the extension is marked is called gauge length.

The load Vs deformation curve is not unique, even for the specimen of the same material. As the geometry (either length or cross-sectional area) of the specimen changes, the load-deformation curve also changes.

On the other hand, the Stress vs Strain curve for a material is unique, irrespective of the geometric dimensions of the material specimen. Thus, for studying engineering properties of a material, Stress-Strain curve is commonly used. The following is an example of a Stress-Strain curve for mild steel specimen.

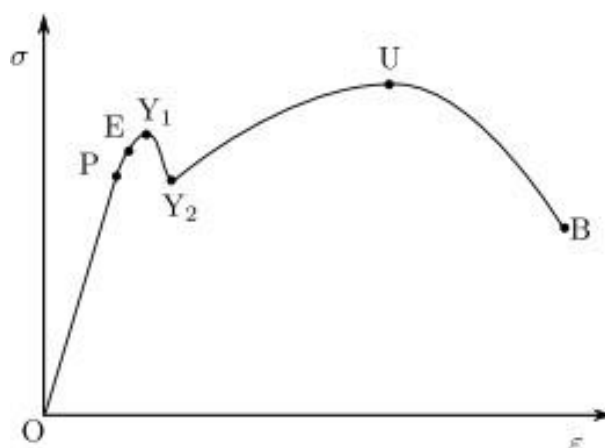

Figure 18. Stress-Strain curve for mild steel Important Points on the Stress-Strain Curve

- **P, Proportionality Limit:**

The point up to which stress is linearly proportional to strain and hence Hooke's law is valid up to P. linear elasticity is valid. The slope of this line OP is nothing but the modulus of elasticity or Young's modulus.

- **E, Elastic Limit:**

The maximum stress that may be developed in a simple tension test such that there is no permanent or residual deformation when the load is entirely removed. Between P and E material is non-linearly elastic

- **Y₁, upper yield point:**

Point around which dislocations break through interstitial carbon atoms and relieve lateral strains. This phenomenon is particular to mild steels.

- **Y₂, lower yield point:**

Once carbon atoms are overcome by the dislocation, relatively lower stresses are required to keep the dislocation moving. This happens around Y₂. This phenomenon is also specific to mild carbon steel. The stress corresponding to this point is called as yield stress or yield strength.

Note: Yield stress is also defined, in other words, as the stress at the which the material begins to deform plastically.

- **U, Ultimate Stress**

Maximum stress in a tensile test is reached at this point. The stress corresponding to this point is called as the Ultimate Strength.

- **B, Breaking point or Rupture**

nt at which specimen fails, breaking into two. The stress corresponding to this point is called as the breaking strength or the rupture strength.

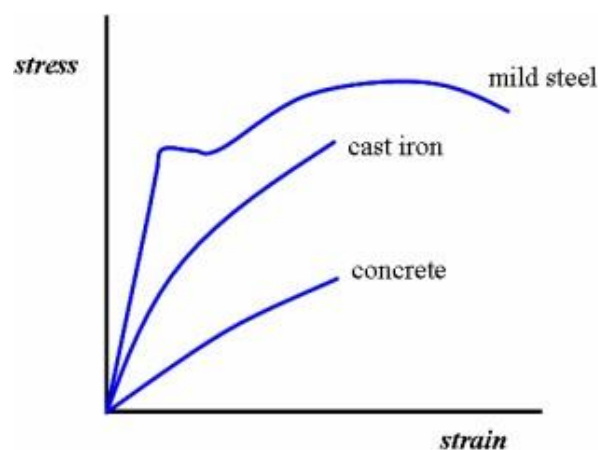
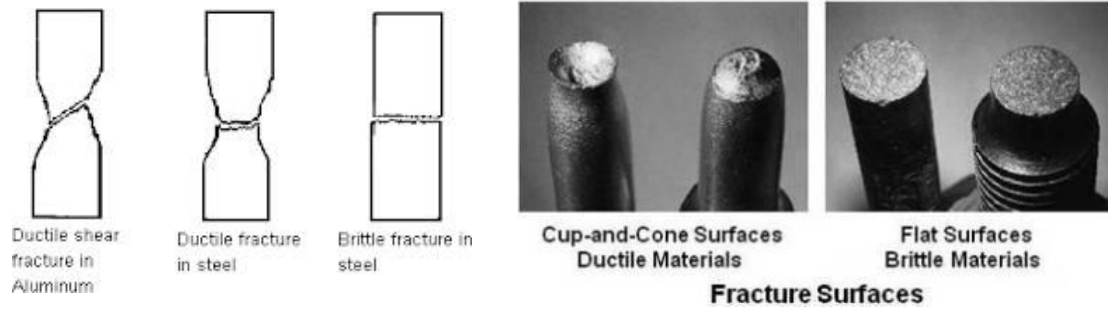

Figure 19. Stress-Strain curve for ductile and brittle materials

It should be noted that for ductile materials fail primarily due to shear stress, and their typical fracture mechanism is cup-and-cone fracture mechanism. While the brittle materials fail, primarily due to normal stress and failure surface is flat, as shown in the following figures.



(a)

(b)

Figure 20. Ductile and brittle failure patterns in materials

Concepts of Permanent Plastic Deformation (Slip, Creep) And Strain- Hardening Cyclic Loading, Fatigue – Endurance Limit and Fatigue Limit

Working Stress and Factor of Safety

Working Stress: Maximum stress to which the material of a member is subjected in practice is called working stress. This is the stress to which a material is actually subjected to a stressed condition. Avoid permanent setting in the member, working stress should be kept less than the elastic limit or permissible stress.

Factor of Safety: Ratio of yield stress to working stress is called factor of safety. And sometime factor of safety is taken as the ratio of ultimate stress to working stress. It is necessary that the working stress should be well below the elastic limit and to achieve this condition, the ultimate stress is divided by factor of safety to obtain working stress.

Lateral Strain and Poisson's Ratio

Strain at right angles to the direction of applied load is known as lateral strain.

- = Increase in length
- = Decrease in breadth
- = Decrease in depth

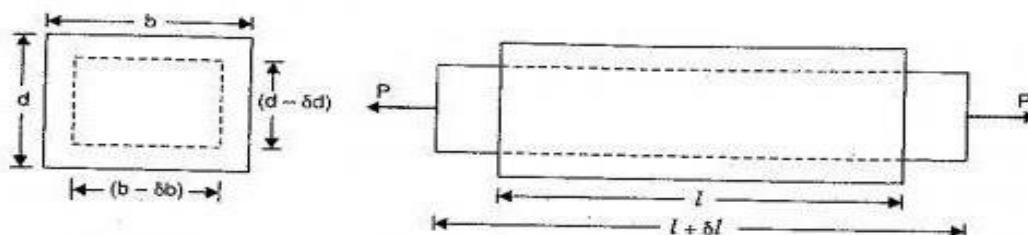

$$\text{Lateral Strain} = -\frac{\delta b}{b} \text{ or } -\frac{\delta d}{d}$$

- If longitudinal strains tensile, lateral strain will be compressive.
- If longitudinal strain is compressive, lateral strain will be tensile.

Poisson's Ratio: Ratio of lateral strain to longitudinal strain is called Poisson's ratio. It is constant for given material, when the material is stresses within elastic limit. It is denoted by ν or $1/m$.

$$\text{Poisson's ratio } (\nu) = \frac{1}{m} = -\frac{\text{Lateral strain}}{\text{Longitudinal strain}}$$

Poisson's Ratio varies from 0.25 to 0.33 for steel and 0.45 to 0.55 for rubber. The value of ν lies between 0 and 0.5.

Three Dimensional Stresses and Strains – Stress Tensor – Generalized

Hooke's Law

Volumetric Strain and Bulk Modulus

Volumetric Strain: Change in dimensions of body will cause some change in its volume. It is the ratio of change in volume to original volume.

$$\epsilon_v = \frac{\delta V}{V} = \epsilon_x + \epsilon_y + \epsilon_z$$

Consider a rectangular bar of length l , breadth b and thickness t , which is subjected to an axial load P in the direction of its length.

- l = Original length of bar,
- δl = Increase in length,
- $l + \delta l$ = Final length,
- b = Original breadth of bar,
- δb = Decrease in breadth,
- $b - \delta b$ = Final breadth,
- t = Original thickness of bar,
- δt = Decrease in thickness,
- $t - \delta t$ = Final thickness
- P = Tensile force acting on the bar,
- E = Modulus of elasticity
- ν = Poisson's Ratio

$$\delta l = \frac{Pl}{AE}$$

Original Volume of body $V = l \times b \times t$

Final Volume = $(l + \delta l) \times (b - \delta b) \times (t - \delta t)$

Final Volume = $l(1 + \frac{\delta l}{l})b(1 - \frac{\delta b}{b})t(1 - \frac{\delta t}{t})$

Final Volume = $lbt(1 + \frac{\delta l}{l})(1 - \frac{\delta b}{b})(1 - \frac{\delta t}{t})$

Final Volume = $lbt[1 - \frac{\delta b}{b} + \frac{\delta l}{l} - \frac{\delta l}{l} \times \frac{\delta b}{b}](1 - \frac{\delta t}{t})$

Final Volume = $lbt[1 - \frac{\delta t}{t} - \frac{\delta b}{b} + (\frac{\delta b}{b} \times \frac{\delta t}{t}) + \frac{\delta l}{l} - (\frac{\delta l}{l} \times \frac{\delta t}{t}) - (\frac{\delta l}{l} \times \frac{\delta b}{b}) + (\frac{\delta l}{l} \times \frac{\delta t}{t} \times \frac{\delta b}{b})]$

Ignoring other negligible value

Final Volume = $lbt[1 + \frac{\delta l}{l} - \frac{\delta b}{b} - \frac{\delta t}{t}]$

Change in Volume $\delta V = \text{Final Volume} - \text{Original Volume}$

$$\delta V = lbt[1 + \frac{\delta l}{l} - \frac{\delta b}{b} - \frac{\delta t}{t}] - lbt$$

$$\delta V = lbt[\frac{\delta l}{l} - \frac{\delta b}{b} - \frac{\delta t}{t}]$$

$$\delta V = V[\frac{\delta l}{l} - \frac{\delta b}{b} - \frac{\delta t}{t}]$$

$$\frac{\delta V}{V} = [\text{linear strain} - \text{lateral strain} - \text{lateral strain}]$$

Volumetric Strain $\epsilon_V = \frac{\delta V}{V} = [\text{linear strain} - 2 \times \text{lateral strain}]$

Change in Volume $\delta V = lbt[\frac{\delta l}{l} - \frac{\delta b}{b} - \frac{\delta t}{t}]$

Change in Volume $\delta V = lbt[\frac{P}{btE} - \nu \frac{P}{btE} - \nu \frac{P}{btE}]$

Change in Volume $\delta V = V \frac{P}{btE} [1 - \nu - \nu]$

Change in Volume $\delta V = V \frac{P}{btE} [1 - 2\nu]$

Volumetric Strain $\epsilon_V = \frac{\delta V}{V} = \frac{P}{btE} [1 - \frac{2}{m}]$

Volumetric Strain $\epsilon_V = [- \frac{2}{m}]$

Volumetric Strain $\epsilon_V = \frac{\delta l}{l} [1 - \frac{2}{m}]$

Volumetric Strain of a rectangular body subjected to three mutually perpendicular forces:

Let $\sigma_x, \sigma_y, \sigma_z$ be the direct tensile stresses acting to x,y,z direction respectively

Type equation here.

$$\epsilon_x = \frac{\sigma_x}{E} - \frac{\sigma_y}{mE} - \frac{\sigma_z}{mE}$$

$$\epsilon_x = \frac{1}{E} [\sigma_x - \frac{\sigma_y}{m} - \frac{\sigma_z}{m}]$$

$$\epsilon_y = \frac{\sigma_y}{E} - \frac{\sigma_x}{mE} - \frac{\sigma_z}{mE}$$

$$\epsilon_y = \frac{1}{E} [\sigma_y - \frac{\sigma_x}{m} - \frac{\sigma_z}{m}]$$

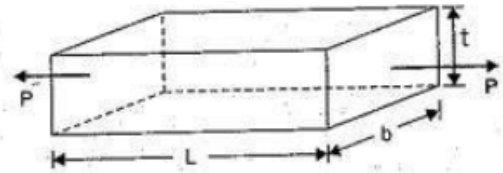

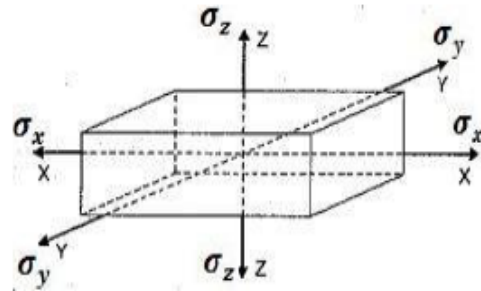

$$\varepsilon_z = \frac{\sigma_z}{E} - \frac{\sigma_y}{mE} - \frac{\sigma_x}{mE} \quad \varepsilon_z = \frac{1}{E} \left[\sigma_z - \frac{\sigma_y}{m} - \frac{\sigma_x}{m} \right]$$

$$\text{Volumetric Strain } \varepsilon_v = \frac{\delta V}{V} = \varepsilon_x + \varepsilon_y + \varepsilon_z$$

$$\varepsilon_v = \frac{\delta v}{V} = \frac{1}{E} (\sigma_x + \sigma_y + \sigma_z) - \frac{2}{mE} (\sigma_x + \sigma_y + \sigma_z)$$

$$\varepsilon_v = \frac{\delta v}{V} = \frac{1}{E} (\sigma_x + \sigma_y + \sigma_z) \left[1 - \frac{2}{m} \right]$$

$$\delta V = \frac{(\sigma_x + \sigma_y + \sigma_z)}{E} V \left[1 - \frac{2}{m} \right]$$

If intensity of stress is same in all direction i.e. $\sigma_x = \sigma_y = \sigma_z = \sigma$

$$\text{Change in Volume } \delta V = \frac{3\sigma V}{E} \left[1 - \frac{2}{m} \right]$$

Elastic Constant:

- 1) **Modulus of elasticity:** Ratio of longitudinal stress to longitudinal strain or linear stress to linear strain. It is denoted by E.

$$\text{Modulus of elasticity (E)} = \frac{\text{Longitudinal stress } (\sigma)}{\text{Longitudinal strain } (\varepsilon)}$$

- 1) **Modulus of Rigidity:** Ratio of shear stress to shear strain. It is denoted by G.

$$\text{Modulus of Rigidity (G)} = \frac{\text{Shear stress } (\tau)}{\text{Shear strain } (\varphi)}$$

- 2) **Bulk Modulus:** When a body is subjected to three mutually perpendicular stresses of equal intensity, the ratio of direct stress to volumetric strain is known as bulk modulus. It is denoted by K.

$$\text{Bulk Modulus } K = \frac{\text{Direct stress}}{\text{Volumetric Strain}} = \frac{\sigma}{\left(\frac{\delta V}{V} \right)}$$

Relations between E, G and K

- $E = 2G \left(1 + \frac{1}{m} \right)$ or $E = 2G (1 + \mu)$
- $E = 3K \left(1 - \frac{2}{m} \right)$ or $E = 3K (1 - \mu)$
- $E = \frac{9KG}{3K + G}$
- $\frac{1}{m} = \frac{3K - 2G}{6K + 2G}$

Bars of Varying Sections

Figure shows a bar which consist of three lengths l_1 l_2 & l_3 with sectional area A_1 , A_2 & A_3 and subjected to an axial load P . Even though the total force on each section is the same, the intensities of stress will be different for three sections.

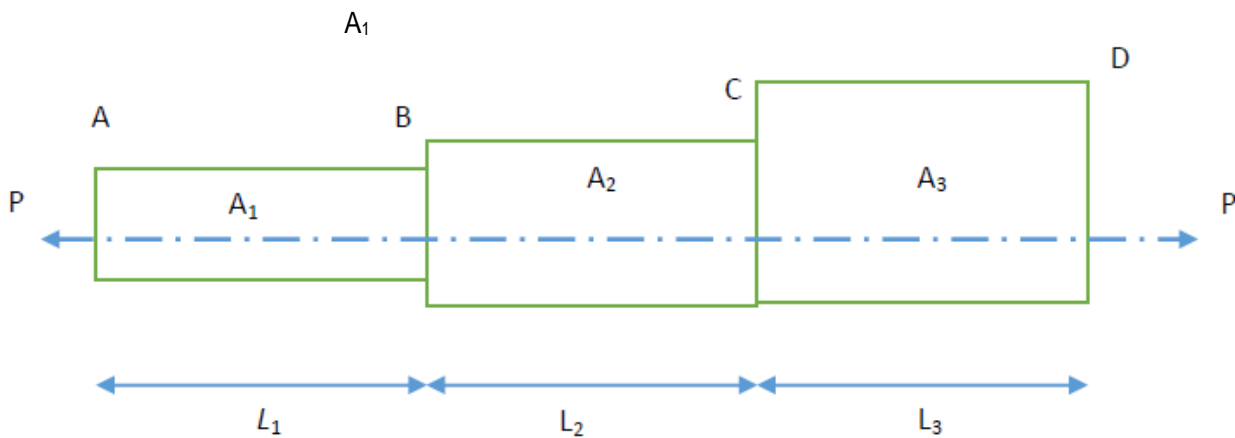

$$\text{Intensity of stress on Section AB} = \sigma_1 = \frac{P}{A_1}$$

$$\text{Intensity of stress on Section BC} = \sigma_2 = \frac{P}{A_2}$$

$$\text{Intensity of stress on Section CD} = \sigma_3 = \frac{P}{A_3}$$

Now let E , be the Young's Modulus

$$\text{Strain on Section AB} = \frac{\sigma_1}{E}$$

$$\text{Strain on Section BC} = \frac{\sigma_2}{E}$$

$$\text{Strain on Section CD} = \frac{\sigma_3}{E}$$

$$\text{Change in length on Section AB} = \delta l_1$$

$$= \epsilon_1 l_1$$

$$\text{Change in length on Section BC} = \delta l_2$$

$$= \epsilon_2 l_2$$

$$\text{Change in length on Section CD} = \delta l_3 = \epsilon_3 l_3$$

$$\text{Total Change in length of bar} = \delta l = \delta l_1 + \delta l_2 + \delta l_3$$

$$\delta l = \frac{Pl_1}{A_1 E} + \frac{Pl_2}{A_2 E} + \frac{Pl_3}{A_3 E}$$

$$\delta l = \frac{P}{E} \left[\frac{l_1}{A_1} + \frac{l_2}{A_2} + \frac{l_3}{A_3} \right]$$

Note: When a body is subjected to a number of forces acting on its outer edge as well as at some other sections, along the length of the body. In such case, the forces are split up and their effects are considered on individual sections. The resulting deformation of the body is equal to the algebraic sum of the deformations of the individual sections, called principle of superposition.

Bars of Composite section or Composite Bars

A bar made up of two or more than two different materials, joined together is called a composite bar.

- 1) The total external load on the composite bar is equal to sum of load carried by each different material
- 2) The extension or compression in each bar is equal. Hence deformation per unit length, i.e. strain in each bar is equal

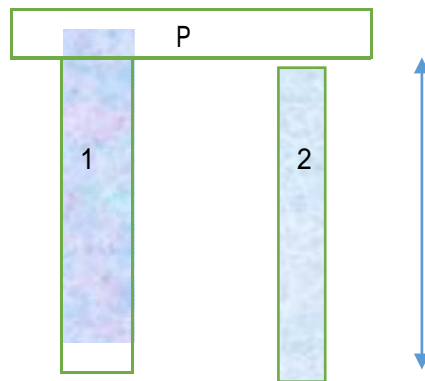

P = Total load on composite bar

l = Length of composite bar and also length of bars of different materials

A_1 = Cross-sectional area of bar 1

A_2 = Cross-sectional area of bar 2

E_1 = Young's Modulus of bar 1

E_2 = Young's Modulus of bar 2

P_1 = Load shared by bar 1

P_2 = Load shared by bar 2

σ_1 = Stress induced in bar 1

σ_2 = Stress induced in bar 2

ϵ_1 = Strain in bar 1

ϵ_2 = Strain in bar 2

By first point discussed above $P = P_1 + P_2$

$$P = \sigma_1 A_1 + \sigma_2 A_2$$

By second point discussed above that strain is same for both bar

Strain in bar 1 (ϵ_1) = Strain in bar 2 (ϵ_2)

$$\frac{\sigma_1}{E_1} = \frac{\sigma_2}{E_2} \quad \sigma_1 = \frac{E_1}{E_2} \sigma_2$$

Where $\frac{E_1}{E_2}$ is known as Modular Ratio.

Thermal stresses or Temperature stresses

Thermal stresses are the stresses induced in a body due to change in temperature. Thermal stresses are setup in a body. When the temperature of body is raised or lowered and the body is not allowed to expand or contract freely. But if the body is allowed to expand or contract freely, no stress will be setup in the body.

You must have notice that in many times is structure will provide a gap between two structural elements. We allow the structural member to expand or contract due to variation in temperature. You must have noticed in the railway tracks are not continuous; some gaps are maintained at a certain distance travel. If this not, then rail track will be subjected to tremendous amount of stress.

Consider a body which is heated at a certain temperature.

l = original length of the body

Δt = variation in temperature

E = young's modulus

α = Co-efficient of linear expansion/ thermal expansion

δl = extension of rod due to rise of temperature

δl is proportional to strain $\Delta t.l$,

$\Delta t = +$ for expansion

$\Delta t = -$ for contraction

If the rod is free to expand $\delta l = \alpha \Delta t.l$

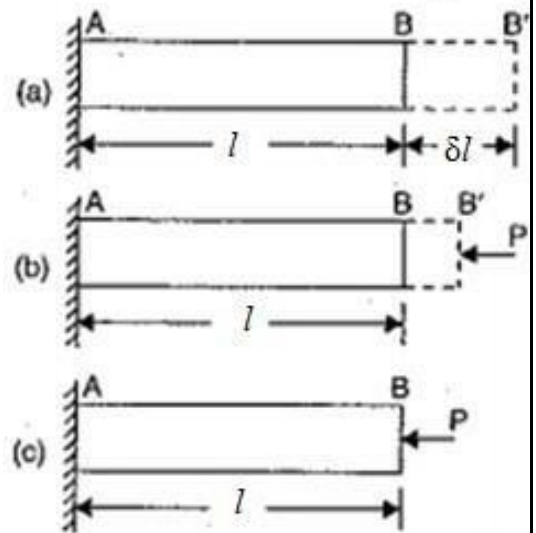

AB represents the original length and BB' represents the increase in length due to temperature rise, Now suppose that an external compressive load P is applied at B' so that the rod is decreased in its length from $(l + \alpha \Delta t.l)$ to $l = (l + \alpha \Delta t.l) - \delta$

$$\text{Total compressive strain} = \frac{\text{Decrease in length}}{\text{Original length}}$$

Thermal strain

$$\epsilon_T = \frac{\alpha \Delta t.l}{l} = \alpha \Delta t$$

Thermal stress

$$\sigma_T = \epsilon_T E = \alpha \Delta t E$$

If ends of body are fixed to rigid supports, so that its expansion is prevented then compressive stress and strain will be set up in the rod. These are known as thermal stress and thermal strain. If supports yield by an amount equal to δ ,

Then the actual expansion = expansion due to rise in temperature $- \delta$
 $= \alpha \Delta t.l - \delta$

$$\text{Actual Strain} = \frac{\text{Actual Expansion}}{\text{Original length}} = \frac{\alpha \Delta t.l - \delta}{l}; \text{ Actual Stress} = \frac{\alpha \Delta t.l - \delta}{l} \times E$$