

I B.TECH – EXAMINATIONS, JUNE - 2011
APPLIED MECHANICS
(CIVIL ENGINEERING)

Time: 3hours

Max.Marks:80

Answer any FIVE questions
 All questions carry equal marks

- - -

- 1.a) What is a force? What are its characteristics? With examples explain composition of forces and resolution of a force.
- b) A barge is pulled by two tug boats as shown in figure 1. If the resultant of the forces exerted by the tug boats is 5 kN force directed along the axis of the barge, determine (i) the tension in each of the ropes knowing that $\alpha = 45^\circ$ and (ii) the value of α such that the tension in the rope 2 is minimum. [8+8]

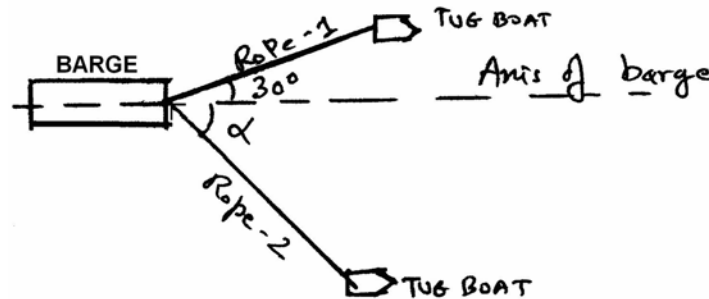

Figure 1

2. The three blocks A, B and C with weights as shown in figure 2 are placed on a 20° incline so that they are in contact with each other at rest. Determine which, if any of the blocks will move and the friction force acting under each. Assume the coefficient of friction as shown below. [16]

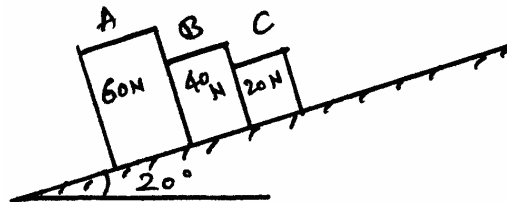

Figure 2

Under the block	Static coefficient of friction	Kinetic coefficient of friction
A	0.5	0.4
B	0.3	0.2
C	0.5	0.4

- 3.a) Derive an expression to find the length of belt required to connect two pulleys at a given distance between them in case of open drive.
- b) An engine running at 160 rpm drives a line shaft by means of a belt. The pulley of the engine is 800 mm in diameter while the pulley on the line shaft is 500 mm. A 1000 mm diameter pulley on the line shaft drives a 150 mm diameter pulley keyed to the machine shaft. Find the speed of the machine shaft
- i) If there is no slip
- ii) If there is a slip of 2.5% at each drive. [8+8]

- 4.a) State and prove parallel axis theorem.
 b) Determine the moment of inertia of a semi-circular lamina of radius 'r' about the diameter from first principle. Also determine the moment of inertia about an axis passing through centroid and parallel to diameter. [8+8]
- 5.a) Explain the mass moment of Inertia.
 b) A rectangular prism of cross-section (a×b) and uniform density 'ρ' has a length 'l' as shown in figure 3. Determine the moment of inertia about the longitudinal and transverse axes passing through the centre of mass. [4+12]

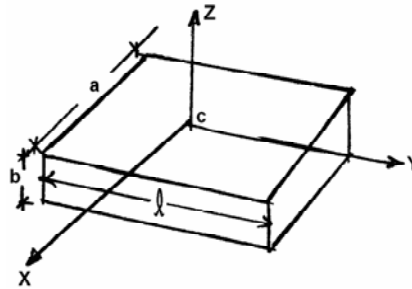

Figure 3

- 6.a) The motion of a particle is described by the following equations

$$x = 2(t+1)^2$$

$$y = 2(t+1)^{-2}$$
 Show that the path travelled by the particle is a rectangular hyperbola. Find also the velocity and the acceleration of the particle at $t = 0$.
 b) A highway curve of 60m radius is super elevated so that the rated speed is 45 km/hr.
 i) Determine the angle of super elevation.
 ii) If skidding is impending when the speed is increased to 80 km/hr. Find the coefficient of friction. [8+8]
7. An engine of mass 550kN pulls a mass of 2600kN up a gradient of 1 in 100 with a uniform speed of 40kmph. Find the power transmitted by the engine if the tractive resistance is 60N per 10kN. Also find the power transmitted by the engine if the acceleration of the engine is 0.2m/sec^2 . [16]
- 8.a) Define the terms:
 i) Period of pendulum.
 ii) Frequency of oscillation.
 b) A body of mass 5N oscillates about a horizontal axis in it at a distance of 400 mm from its centre of gravity. If the moment of inertia about the central axis parallel to the axis of rotation be $\frac{10}{8}\text{Nm}^2$. Find the length of the equivalent simple pendulum. [6+10]

* * * * *

I B.TECH – EXAMINATIONS, JUNE - 2011
APPLIED MECHANICS
(CIVIL ENGINEERING)

Time: 3hours

Max.Marks:80

Answer any FIVE questions
All questions carry equal marks

- - -

- 1.a) Derive an expression to find the length of belt required to connect two pulleys at a given distance between them in case of open drive.
- b) An engine running at 160 rpm drives a line shaft by means of a belt. The pulley of the engine is 800 mm in diameter while the pulley on the line shaft is 500 mm. A 1000 mm diameter pulley on the line shaft drives a 150 mm diameter pulley keyed to the machine shaft. Find the speed of the machine shaft
- i) If there is no slip
 ii) If there is a slip of 2.5% at each drive. [8+8]
- 2.a) State and prove parallel axis theorem.
- b) Determine the moment of inertia of a semi-circular lamina of radius 'r' about the diameter from first principle. Also determine the moment of inertia about an axis passing through centroid and parallel to diameter. [8+8]
- 3.a) Explain the mass moment of Inertia.
- b) A rectangular prism of cross-section (a×b) and uniform density 'ρ' has a length 'l' as shown in figure 3. Determine the moment of inertia about the longitudinal and transverse axes passing through the centre of mass. [4+12]

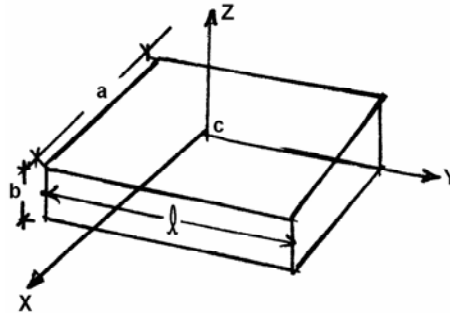

Figure 3

- 4.a) The motion of a particle is described by the following equations

$$x = 2(t+1)^2$$

$$y = 2(t+1)^{-2}$$

Show that the path travelled by the particle is a rectangular hyperbola. Find also the velocity and the acceleration of the particle at $t = 0$.

- b) A highway curve of 60m radius is super elevated so that the rated speed is 45 km/hr.
- i) Determine the angle of super elevation.
 ii) If skidding is impending when the speed is increased to 80 km/hr. Find the coefficient of friction. [8+8]

5. An engine of mass 550kN pulls a mass of 2600kN up a gradient of 1 in 100 with a uniform speed of 40kmph. Find the power transmitted by the engine if the tractive resistance is 60N per 10kN. Also find the power transmitted by the engine if the acceleration of the engine is 0.2m/sec^2 . [16]

6.a) Define the terms:

- i) Period of pendulum.
 - ii) Frequency of oscillation.
- b) A body of mass 5N oscillates about a horizontal axis in it at a distance of 400 mm from its centre of gravity. If the moment of inertia about the central axis parallel to the axis of rotation be $\frac{10}{8}\text{Nm}^2$. Find the length of the equivalent simple pendulum. [6+10]

7.a) What is a force? What are its characteristics? With examples explain composition of forces and resolution of a force.

- b) A barge is pulled by two tug boats as shown in figure 1. If the resultant of the forces exerted by the tug boats is 5 kN force directed along the axis of the barge, determine (i) the tension in each of the ropes knowing that $\alpha = 45^\circ$ and (ii) the value of α such that the tension in the rope 2 is minimum. [8+8]

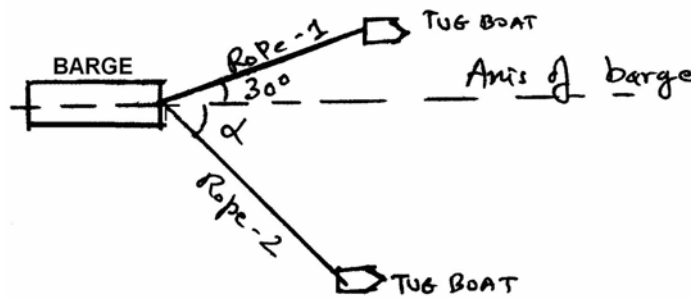

Figure 1

8. The three blocks A, B and C with weights as shown in figure 2 are placed on a 20° incline so that they are in contact with each other at rest. Determine which, if any of the blocks will move and the friction force acting under each. Assume the coefficient of friction as shown below. [16]

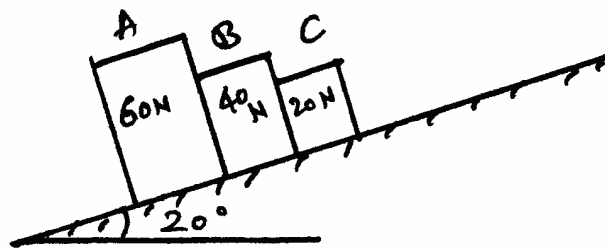

Figure 2

Under the block	Static coefficient of friction	Kinetic coefficient of friction
A	0.5	0.4
B	0.3	0.2
C	0.5	0.4

I B.TECH – EXAMINATIONS, JUNE - 2011
APPLIED MECHANICS
(CIVIL ENGINEERING)

Time: 3hours

Max.Marks:80

Answer any FIVE questions
All questions carry equal marks

- - -

- 1.a) Explain the mass moment of Inertia.
 b) A rectangular prism of cross-section ($a \times b$) and uniform density ' ρ ' has a length ' l ' as shown in figure 3. Determine the moment of inertia about the longitudinal and transverse axes passing through the centre of mass. [4+12]

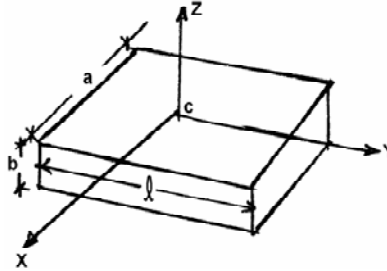

Figure 3

- 2.a) The motion of a particle is described by the following equations

$$x = 2(t+1)^2$$

$$y = 2(t+1)^{-2}$$

Show that the path travelled by the particle is a rectangular hyperbola. Find also the velocity and the acceleration of the particle at $t = 0$.

- b) A highway curve of 60m radius is super elevated so that the rated speed is 45 km/hr.
 i) Determine the angle of super elevation.
 ii) If skidding is impending when the speed is increased to 80 km/hr. Find the coefficient of friction. [8+8]

3. An engine of mass 550kN pulls a mass of 2600kN up a gradient of 1 in 100 with a uniform speed of 40kmph. Find the power transmitted by the engine if the tractive resistance is 60N per 10kN. Also find the power transmitted by the engine if the acceleration of the engine is 0.2m/sec^2 . [16]

- 4.a) Define the terms:
 i) Period of pendulum.
 ii) Frequency of oscillation.
 b) A body of mass 5N oscillates about a horizontal axis in it at a distance of 400 mm from its centre of gravity. If the moment of inertia about the central axis parallel to the axis of rotation be $\frac{10}{8}\text{Nm}^2$. Find the length of the equivalent simple pendulum. [6+10]

- 5.a) What is a force? What are its characteristics? With examples explain composition of forces and resolution of a force.
- b) A barge is pulled by two tug boats as shown in figure 1. If the resultant of the forces exerted by the tug boats is 5 kN force directed along the axis of the barge, determine (i) the tension in each of the ropes knowing that $\alpha = 45^\circ$ and (ii) the value of α such that the tension in the rope 2 is minimum. [8+8]

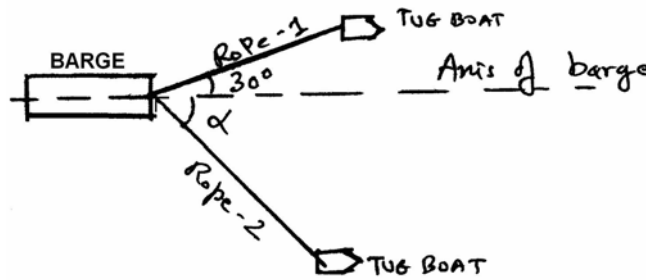

Figure 1

6. The three blocks A, B and C with weights as shown in figure 2 are placed on a 20° incline so that they are in contact with each other at rest. Determine which, if any of the blocks will move and the friction force acting under each. Assume the coefficient of friction as shown below. [16]

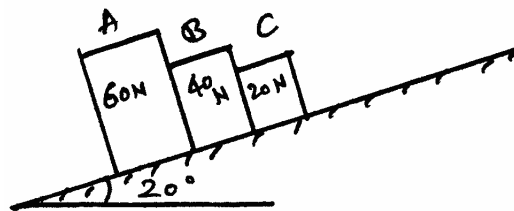

Figure 2

Under the block	Static coefficient of friction	Kinetic coefficient of friction
A	0.5	0.4
B	0.3	0.2
C	0.5	0.4

- 7.a) Derive an expression to find the length of belt required to connect two pulleys at a given distance between them in case of open drive.
- b) An engine running at 160 rpm drives a line shaft by means of a belt. The pulley of the engine is 800 mm in diameter while the pulley on the line shaft is 500 mm. A 1000 mm diameter pulley on the line shaft drives a 150 mm diameter pulley keyed to the machine shaft. Find the speed of the machine shaft
- i) If there is no slip
- ii) If there is a slip of 2.5% at each drive. [8+8]
- 8.a) State and prove parallel axis theorem.
- b) Determine the moment of inertia of a semi-circular lamina of radius 'r' about the diameter from first principle. Also determine the moment of inertia about an axis passing through centroid and parallel to diameter. [8+8]

I B.TECH – EXAMINATIONS, JUNE - 2011
APPLIED MECHANICS
(CIVIL ENGINEERING)

Time: 3hours

Max.Marks:80

Answer any FIVE questions
 All questions carry equal marks

- - -

1. An engine of mass 550kN pulls a mass of 2600kN up a gradient of 1 in 100 with a uniform speed of 40kmph. Find the power transmitted by the engine if the tractive resistance is 60N per 10kN. Also find the power transmitted by the engine if the acceleration of the engine is 0.2m/sec^2 . [16]
- 2.a) Define the terms:
 - i) Period of pendulum.
 - ii) Frequency of oscillation.
- b) A body of mass 5N oscillates about a horizontal axis in it at a distance of 400 mm from its centre of gravity. If the moment of inertia about the central axis parallel to the axis of rotation be $\frac{10}{8}\text{Nm}^2$. Find the length of the equivalent simple pendulum. [6+10]
- 3.a) What is a force? What are its characteristics? With examples explain composition of forces and resolution of a force.
- b) A barge is pulled by two tug boats as shown in figure 1. If the resultant of the forces exerted by the tug boats is 5 kN force directed along the axis of the barge, determine (i) the tension in each of the ropes knowing that $\alpha = 45^\circ$ and (ii) the value of α such that the tension in the rope 2 is minimum. [8+8]

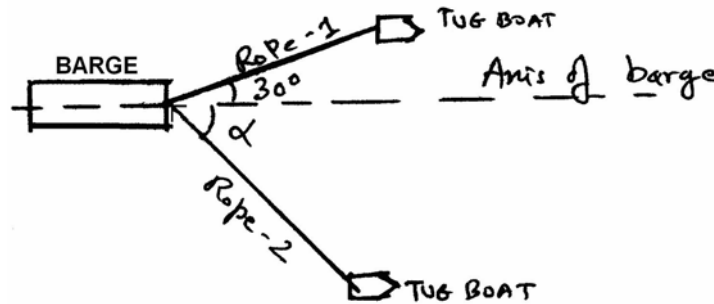

Figure 1

4. The three blocks A, B and C with weights as shown in figure 2 are placed on a 20° incline so that they are in contact with each other at rest. Determine which, if any of the blocks will move and the friction force acting under each. Assume the coefficient of friction as shown below. [16]

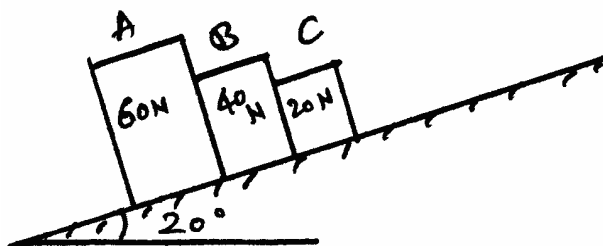

Figure 2

Under the block	Static coefficient of friction	Kinetic coefficient of friction
A	0.5	0.4
B	0.3	0.2
C	0.5	0.4

- 5.a) Derive an expression to find the length of belt required to connect two pulleys at a given distance between them in case of open drive.
- b) An engine running at 160 rpm drives a line shaft by means of a belt. The pulley of the engine is 800 mm in diameter while the pulley on the line shaft is 500 mm. A 1000 mm diameter pulley on the line shaft drives a 150 mm diameter pulley keyed to the machine shaft. Find the speed of the machine shaft
- If there is no slip
 - If there is a slip of 2.5% at each drive. [8+8]
- 6.a) State and prove parallel axis theorem.
- b) Determine the moment of inertia of a semi-circular lamina of radius 'r' about the diameter from first principle. Also determine the moment of inertia about an axis passing through centroid and parallel to diameter. [8+8]
- 7.a) Explain the mass moment of Inertia.
- b) A rectangular prism of cross-section (a×b) and uniform density 'ρ' has a length 'l' as shown in figure 3. Determine the moment of inertia about the longitudinal and transverse axes passing through the centre of mass. [4+12]

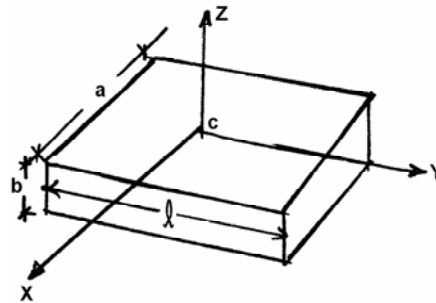

Figure 3

- 8.a) The motion of a particle is described by the following equations
- $$x = 2(t+1)^2$$
- $$y = 2(t+1)^{-2}$$
- Show that the path travelled by the particle is a rectangular hyperbola. Find also the velocity and the acceleration of the particle at $t = 0$.
- b) A highway curve of 60m radius is super elevated so that the rated speed is 45 km/hr.
- Determine the angle of super elevation.
 - If skidding is impending when the speed is increased to 80 km/hr. Find the coefficient of friction. [8+8]

* * * * *