

Roll No
EE-111
B.E. (All Branches), I Year II Semester
 Examination, June 2016
Choice Based Credit System (CBCS)
Fundamentals of Electrical Engineering
Time : Three Hours
Maximum Marks : 60

- Note :** i) Attempt any five questions.
 ii) All questions carry equal marks.

1. a) State and explain Kirchoff's Law with suitable example.
 b) Find the value of current 'I'.

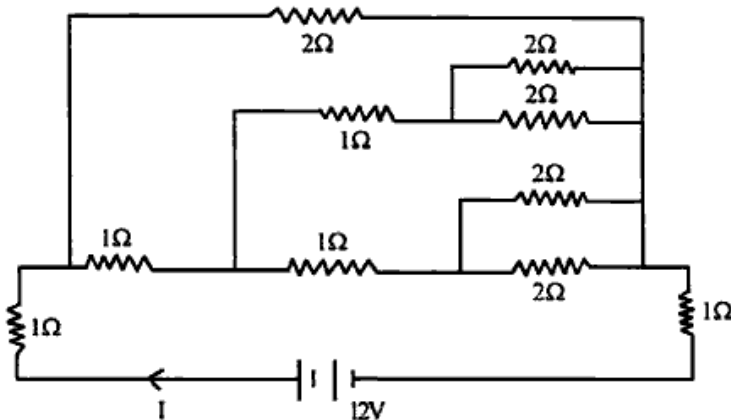

2. a) Define the following term:
 i) Active power ii) Reactive power
 iii) Apparent power iv) Power factor
 v) Alternation vi) Frequency
 b) Show that the power consumed by a pure inductive circuit is zero.
 c) Derive an expression for series resonance of a R-L-C series AC circuit.

3. a) Derive the relation between line quantities and phase quantities for balanced star connections.
 b) Write down the advantages of 3- ϕ system over single phase system.
4. a) Compare the Electrical circuit with magnetic circuit.
 b) Define the following term:
 i) MMF ii) Flux
 iii) Permeability iv) Magnetic field intensity
 v) Susceptance vi) Magnetic field density
5. a) State and explain laws of electromagnetic induction.
 b) Draw the electrical equivalent circuit and write down the equivalent equations.

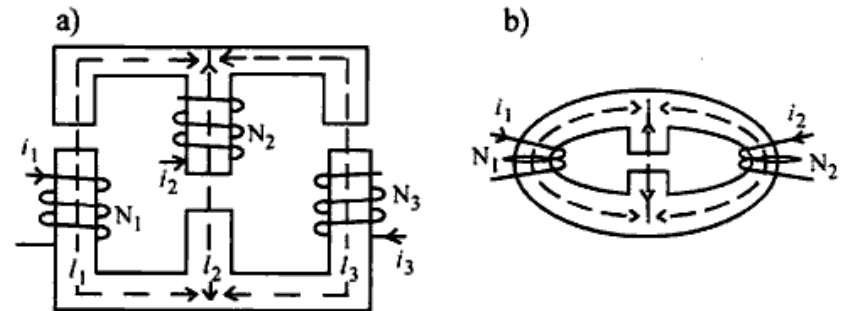

6. a) Derive an EMF equation of a single phase transformer.
 b) Show that the transformer is a constant flux device.
 c) State and explain no load current with their components.
- a) Write down the constructional features of a D.C. Machine with neat and suitable diagrams.
 b) Discuss various types of losses occurs in various electrical machines.
