

For the tuned amplifier shown in figure. Determine the

- Resonant frequency
- Q of tank circuit
- B.W. of amplifier

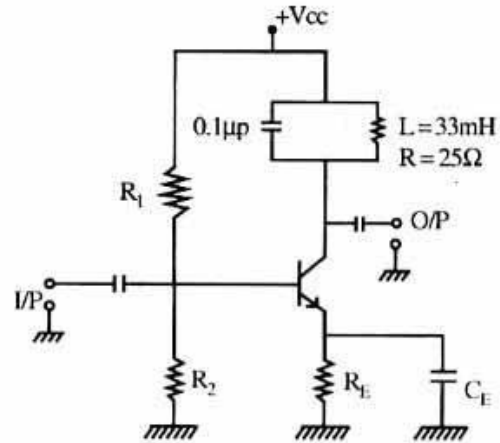

Roll No

EX - 304

B.E. III Semester

Examination, December 2015

Electronic Devices and Circuits - I

Time : Three Hours

Maximum Marks : 70

- Note:**
- Answer five questions. In each question part A, B, C is compulsory and D part has internal choice.
 - All parts of each question are to be attempted at one place.
 - All questions carry equal marks, out of which part A and B (Max. 50 words) carry 2 marks, part C (Max. 100 words) carry 3 marks, part D (Max. 400 words) carry 7 marks.
 - Except numericals, Derivation, Design and Drawing etc.

- What happens to the width of the depletion layer of a p-n junction when it is
 - Forward biased
 - Reverse biased
 - Explain why a photodiode is usually operated under reverse bias.
 - Differentiate between half wave and full wave centre tap rectifier.
 - Explain the voltage stabilization capabilities of a zener diode through a simple circuit.

OR

Explain the LED, draw its constructional diagram and write its advantages and disadvantages.

[2]

2. a) Compare the features of the three transistor configurations.
- b) Draw and explain the equivalent circuit of UJT.
- c) What are the differences between BJT and JFET.
- d) Draw the voltage divider circuit and derive an expression for its stability factors.

OR

Explain the principle of operation of UJT and mention its applications.

3. a) Explain the Darlington amplifier.
- b) Draw h-mode circuit for CE.
- c) Drive the relation between amplification factors.
- d) Explain the midband analysis of single stage CB amplifier.

OR

Explain the analysis of low frequency response of RC coupled amplifier in CE configuration.

4. a) What are the condition for sustained oscillations?
- b) State the frequency of RC phase shift oscillator.
- c) Explain the effect of negative feedback on bandwidth, gain and input impedance.
- d) Derive the expression for frequency of oscillation of Wein bridge oscillator.

[3]

OR

Calculate the voltage gain of the circuit.

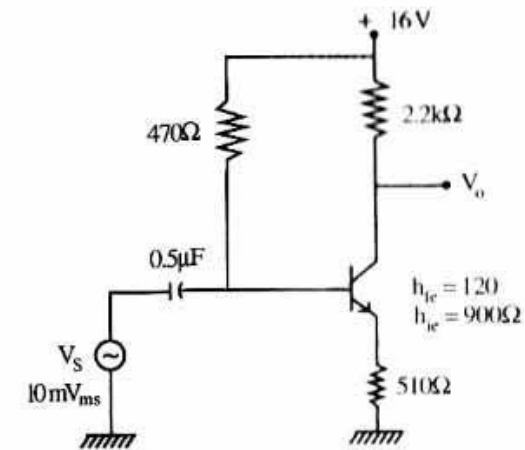

5. a) What are the advantages of double tuned over single tuned?
- b) Why is driver stage necessary for push-pull circuit?
- c) Show that maximum collector efficiency of class A transformer coupled power amplifier is 50%.
- d) A class A transformer coupled power amplifier has zero signal collector current of 50mA. If the collector supply voltage is 5V, find
 - i) The maximum a.c. power output
 - ii) The power rating of transistor
 - iii) The maximum collector efficiency

OR