

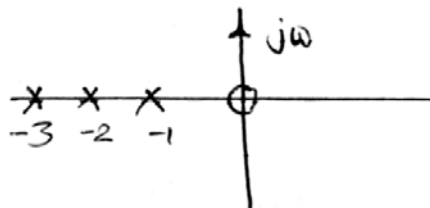

- iii) Addition of a pole to the close loop transfer function
- a) increases rise time b) decreases rise time
- c) increases overshoot d) has no effect.
- iv) The transfer function of a system having a gain of 9 and a pole zero map as in figure below is



- a) $\frac{9(s+1)(s+2)(s+3)}{s}$ b) $\frac{9(s-1)(s-2)(s-3)}{s}$
- c) $\frac{9s(s+1)}{(s+2)(s+3)}$ d) $\frac{9s}{(s+1)(s+2)(s+3)}$
- v) The TF of a network $\frac{1+0.5s}{2+s}$ is known as
- a) High pass system
- b) Lead network
- c) Lag network
- d) Proportional controller.
- vi) If the Nyquist plot of a certain feedback system crosses the negative real axis at -0.1 point, the gain margin of the system is given by
- a) 0.1 b) 10
- c) 100 d) none of these.



- xi) The root locus is symmetrical w.r.t.
 - a) negative real axis
 - b) positive real axis
 - c) imaginary axis
 - d) positive & negative real axis.
- xii) A feedback control system is basically
 - a) high pass filter
 - b) band pass filter
 - c) low pass filter
 - d) none of these.

GROUP – B

(Short Answer Type Questions)

Answer any *three* of the following $3 \times 5 = 15$

- 2. Consider the following mechanical translational system shown in figure below. F denotes force, x denotes displacement, M denotes mass and B denotes friction coefficient and K denotes spring constant.

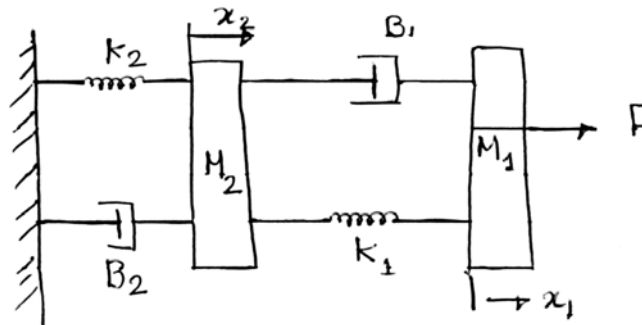

- i) Write down the differential equation(s) governing the above system.
- ii) Draw the corresponding electrical equivalent circuit using force-voltage analogy.

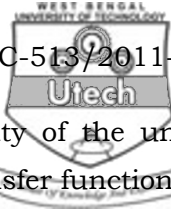

3. Using Routh criterion investigate the stability of the unity feedback control system whose open loop transfer function is

$$G(s) = \frac{e^{-sT}}{s(s+2)}$$

For what value of T will the system be stable ?

4. A system is represented by

$$\dot{X} = \begin{bmatrix} -3 & -2 \\ -1 & -2 \end{bmatrix} X + \begin{bmatrix} 1 \\ 1 \end{bmatrix} U(t)$$

$$Y = [1 \ 2] X$$

Find the poles of the system. Assume $D = 0$.

5. Find the Z -transfer function of the system defined by

$$y(n) - 0.5y(n-1) = x(n-2) - 5x(n-2) + 6x(n) \text{ where } y(n) \text{ and } x(n) \text{ denote output and input sequences respectively.}$$

6. For the system defined by $G(s) = \frac{5(s-1)}{(s+2)(s+5)}$ draw the approximate root-locus diagram.

7. Using Mason's Gain formula, determine the transfer function of the system.

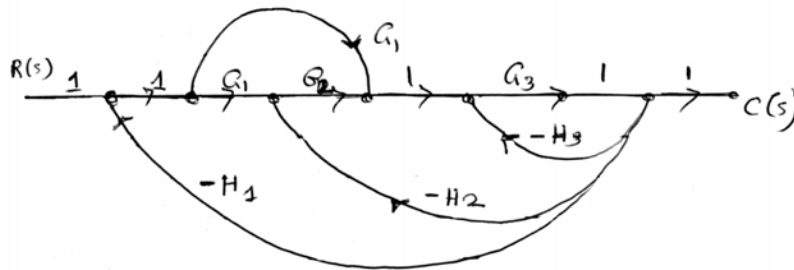

8. Obtain the Z -transform for a unit-step function.



GROUP - C

(Long Answer Type Questions)

Answer any *three* of the following. $3 \times 15 = 45$

9. a) A unity feedback control system has an open loop transfer function

$$G(s) = \frac{k}{(s^2 + 8s + 32)}$$

Sketch the root locus of the system and deduce how the peak overshoot varies with increasing k if the loop is closed. 5 + 5

- b) What kind of controller would you recommend for this system ? 5

10. Prove that for a standard second order system defined by

$$G(s) = \frac{W_n^2}{s^2 + 2\xi W_n s + W_n^2},$$

the peak overshoot due to a step

input depends on ξ only. Prove further that the constant ξ lines pass through the origin of the $(\sigma i j \omega)$ plane. 10 + 5

11. a) Derive the transfer function for a zero-order hold. 5

- b) A continuous function $y(t)$ is sampled by an impulse sampler as shown below :

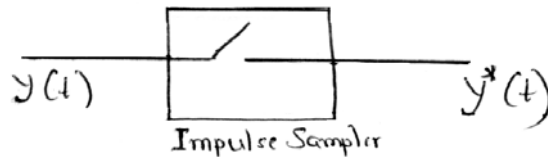

Obtain the Laplace transform for $y^*(t)$ 5

- c) Obtain the Z-transform for $x[n] = |a|^n$ and comment on the ROC. 5



12. The open-loop transfer function of a unity feedback control system is given by

$$G(s) = \frac{s + 0.25}{s^2(s + 1)(s + 0.5)}$$

Determine the closed-loop stability by applying Nyquist criterion.

13. Sketch the Bode Plot for the transfer function defined by

$$G(s)H(s) = \frac{2(s + 0.2)}{s^2 + (s + 1)(s + 0.5)}$$

Determine

- a) phase cross-over frequency
- b) gain cross-over frequency
- c) gain margin
- d) phase margin. 7 + 8

14. a) Determine the transfer matrix for a system whose A, B, C matrices are :

$$A = \begin{bmatrix} 1 & -2 \\ 4 & -5 \end{bmatrix}, \quad B = \begin{bmatrix} 2 \\ 1 \end{bmatrix}, \quad C = [1 \quad 1] \quad 6$$

- b) Is the system stable ? 4
- c) Is the system controllable ? Assume $D = 0$. 5

=====