

I B.TECH – EXAMINATIONS, JUNE - 2011
ENGINEERING DRAWING

Time: 3hours

Max.Marks:75

Answer any FIVE questions
 All questions carry equal marks

- - -

- Two straight lines, OA and OB make an angle of 75° between them. P is a point 40 mm from OA and 50 mm from OB. Draw a hyperbola through P, with OA and OB as asymptotes. [15]
- A line AB, 75mm long is in second quadrant with the end, A in the HP and the end, B in the VP. The line is inclined at 30° to HP and at 45° to VP. Draw the projections of AB and determine its traces. [15]
- A thin rectangular plate of sides, 60 mm \times 30 mm has its shorter edge in V.P and that shorter edge is inclined at 30° to H.P. Project its top view if its front view is a square of 30 mm long. [15]
- A cylinder, 65 mm diameter and 90 mm long has its axis parallel to the H.P and is inclined at 30° to V.P. It is cut by a vertical section plane in such a way that the true shape of the section is an ellipse having a major axis, 75 mm long. Draw its sectional front view and true shape of the section. [15]
- A square prism of base 50 mm side and height 125 mm stands on the ground with the side of its base inclined at 30° to V.P. It is penetrated by a cylinder, 50 mm diameter and 125 mm long, whose axis is parallel to both H.P and V.P and bisects the axis of the prism. Draw the projections showing fully the curves of intersection. [15]
- Draw the isometric projection of the following views as shown in figure 1. All dimensions are in mm. [15]

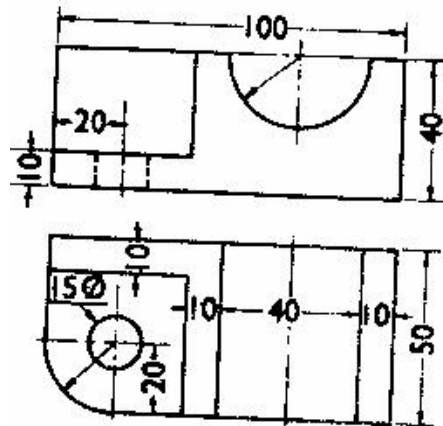

Fig: 1

7. Draw the front view, both sides view and top view of the following figure 2. All dimensions are in mm. [15]

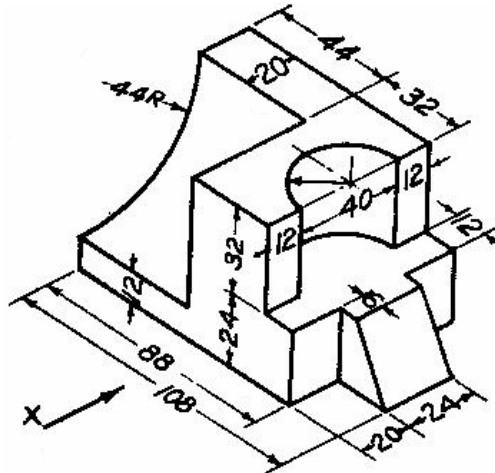

Fig: 2

8. Draw the perspective view of a square prism of base 10 cm side and 12 cm height. The nearest edge of the base is parallel to and 3 cm behind the picture plane. The station point is situated at a distance of 30 cm from the picture plane and 6 cm above the ground plane and 20 cm to the right of the apex. [15]

I B.TECH – EXAMINATIONS, JUNE - 2011
ENGINEERING DRAWING

Time: 3hours

Max.Marks:75

Answer any FIVE questions
All questions carry equal marks

- - -

1. Construct a hypocycloid with rolling circle of 50 mm diameter and directing circle of 175 mm diameter. Draw a tangent to it at a point 50 mm from the centre of the directing circle. [15]
2. A line PQ is 75 mm long and lies in an auxiliary inclined plane which makes an angle of 45° with the H.P. The front view of the line measures 55 mm and the end P is in V.P and 20 mm above H.P. Draw the projections of PQ and find its inclinations with both the planes and their traces. [15]
3. A pentagonal pyramid has an edge of the base in the V.P is inclined at 30° to the H.P., while the triangular face containing that edge makes an angle of 45° to the V.P. Draw the three views of the pyramid, if the edge of the base is 30 mm and that of axis is 80 mm. [15]
4. Draw the development of the lateral surface of the truncated triangular pyramid resting on H.P with one of its edges perpendicular to V.P and is cut by a plane inclined at 30° to H.P and the plane is passing through the axis at a distance of 20 mm from the vertex. The edge of the base is 30 mm and the length of the axis is 40 mm. [15]
5. A cylinder 50 mm diameter and 100 mm long is centrally penetrated by a cone of 50 mm diameter and 75 mm height. The axis of the cylinder which is vertical, cuts the axis of the cone which is horizontal at 30 mm from the base of the cone. Draw the front view showing the curves of penetration. [15]
6. Draw the isometric projection of the following views as shown in figure 1. All dimensions are in mm. [15]

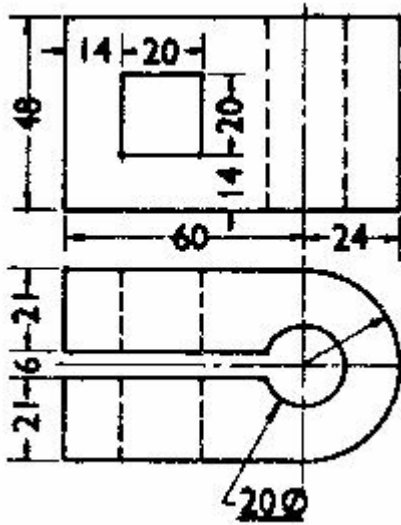

Fig: 1

7. Draw the front view, top view and both side views of the following figure 2. All dimensions are in mm. [15]

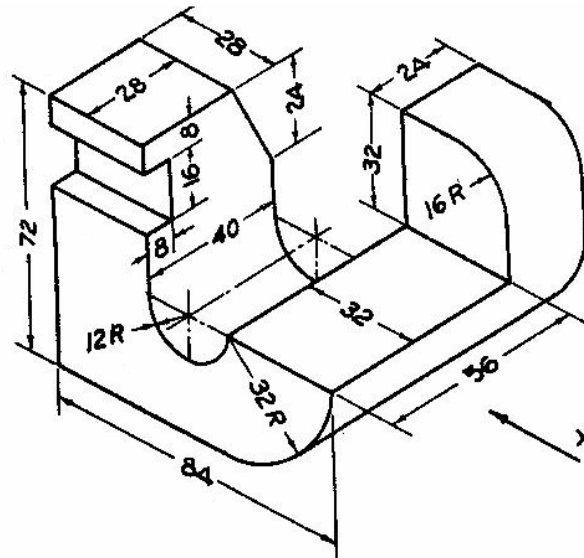

Fig: 2

8. Draw the perspective view of a pentagonal prism, lying on the ground plane on one of its rectangular faces, the axis being inclined at 30° to the picture plane, and a corner of the base touching the picture plane. The station point is 6.5 mm in front of the picture plane and lies in the central plane which bisects the axis. The horizon is at the level of the top edge of the prism. [15]

I B.TECH – EXAMINATIONS, JUNE - 2011
ENGINEERING DRAWING

Time: 3hours

Max.Marks:75

Answer any FIVE questions
All questions carry equal marks

- - -

1. The major axis of the ellipse is 100 mm and the minor axis is 55 mm. Find the foci and construct the ellipse by “Arc of circles method”. Also draw a pair of tangents from any point, P outside the ellipse. [15]
2. The projections of the ends of a line AB are on the same projector. The end A is 30 mm below H.P and 15 mm behind V.P. The end B is 35 mm above H.P and 40 mm in front of V.P. Determine its true length, traces and the inclinations with the reference planes. [15]
3. A hexagonal plate of side, 40mm, is resting on a corner in VP with its surface making an angle of 30° with the VP. The front view of the diagonal passing through that corner is inclined at 45° to the line, xy. Draw the projections of the plate using auxiliary plane method. [15]
4. A square pyramid, base 50 mm side and axis 75 mm long, is resting on H.P on one of its triangular faces, the top view of the axis making an angle of 30° with V.P. It is cut by a horizontal section plane, the V.T of which intersects the axis at a point 6 mm from the base. Draw the front view, sectional top view and the development of the sectioned pyramid. [15]
5. A cylinder of 75 mm diameter and 125 mm height stands on its base on the ground. It is penetrated centrally by a cylinder, 50 mm diameter and 125 mm long, whose axis is parallel to H.P, but inclined at 30° to V.P. Draw the projections showing the curves of intersection. [15]
6. Draw the isometric projection of the following views as shown in figure 1. All dimensions are in mm. [15]

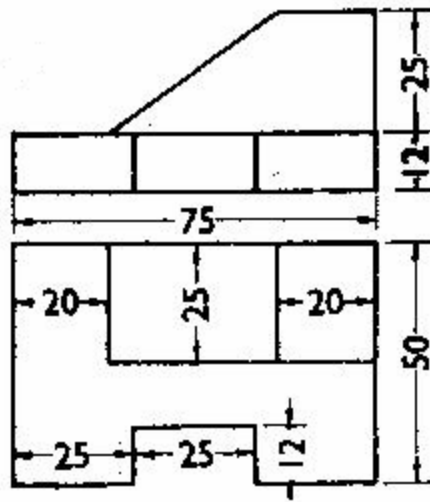

Fig: 1

7. Draw the front, top and right side views of the following as shown in figure 2. All dimensions are in mm. [15]

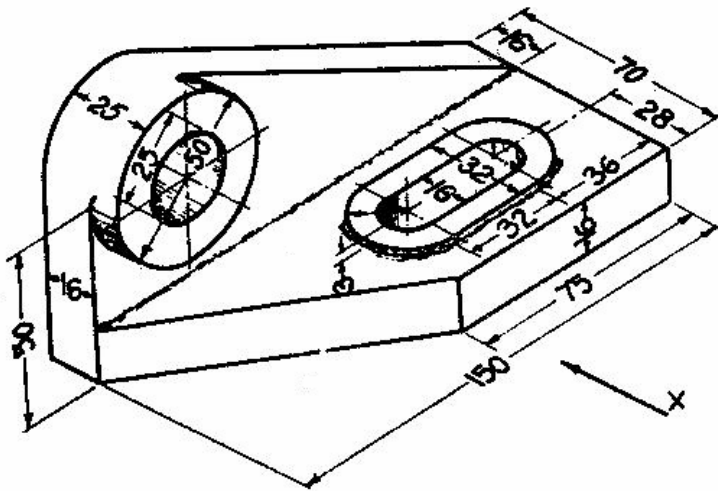

Fig: 2

8. Draw the perspective view of a pentagonal prism, lying on the ground plane on one of its rectangular faces, the axis being inclined at 30° to the picture plane, and a corner of the base touching the picture plane. The station point is 6.5 mm in front of the picture plane and lies in the central plane which bisects the axis. The horizon is at the level of the top edge of the prism. [15]

I B.TECH – EXAMINATIONS, JUNE - 2011
ENGINEERING DRAWING

Time: 3hours

Max.Marks:75

Answer any FIVE questions
All questions carry equal marks

- - -

- 1.a) The actual length of 500 m is represented by a line of 15 cm on a drawing. Construct a vernier scale to read upto 600 m. Mark on it, the lengths, 549 m, 371 m and 402 m.
- b) Construct a regular pentagon of side, 30 mm. [15]
2. A line AB measures 100 mm. The projectors through its V.T and the end A are 40 mm apart. The point A is 30 mm below H.P and 20 mm behind V.P. The V.T is 10 mm above H.P. Draw the projections of the line and determine its H.T and inclinations with H.P and V.P. [15]
3. A thin pentagonal plate of 60 mm long edges has one of its edges in the H.P and perpendicular to V.P while its farthest corner is 60 mm above the H.P. Draw the projections of the plate. Project another front view on Auxiliary Vertical Plane (A.V.P) making an angle of 45^0 with V.P. [15]
4. A cone, base 65 mm diameter and axis 75 mm long, is lying on H.P on one of its generators with the axis parallel to V.P. A section plane which is parallel to V.P cuts the cone 6 mm away from the axis. Draw the sectional front view and the development of the surface of the remaining portion of the cone. [15]
5. A vertical cylinder of 60 mm diameter is penetrated by a square prism of 35 mm side, the axis of which is inclined at 30^0 to the ground, but parallel to V.P. The faces of the prism are equally inclined to the V.P and the axis of the prism is 10 mm in front of the axis of the cylinder. Draw the projections of the solids showing the curves of penetration. [15]
6. Draw the isometric projection of the following views as shown in figure 1. All dimensions are in mm. [15]

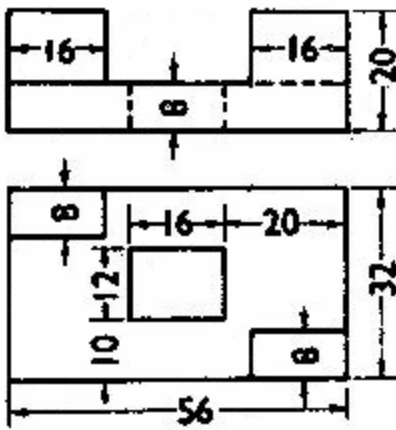

Fig: 1

7. Draw the front, top and left side views of the following figure 2. All dimensions are in mm. [15]

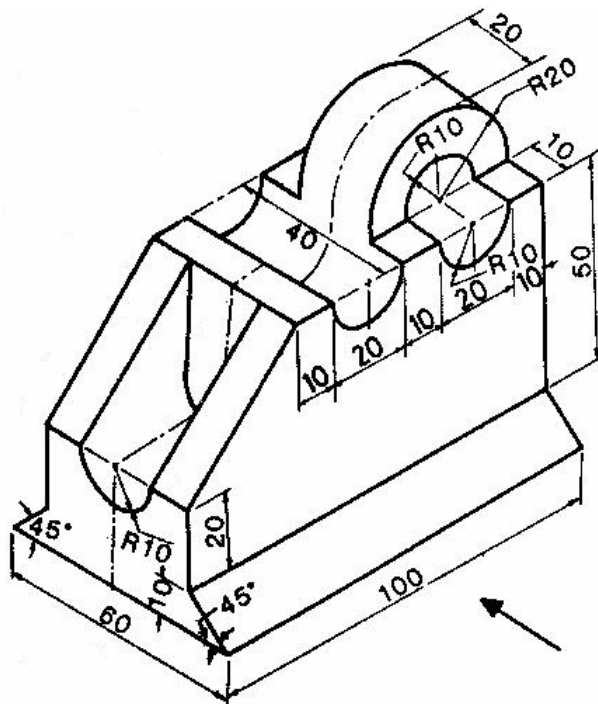

Fig: 2

8. Draw the perspective view of a square prism of base 10 cm side and 12 cm height. The nearest edge of the base is parallel to and 3 cm behind the picture plane. The station point is situated at a distance of 30 cm from the picture plane and 6 cm above the ground plane and 20 cm to the right of the apex. [15]
