



Name :

Roll No. :

Invigilator's Signature :

CS/B.Tech (ME/PE)/SEM-5/ME-503/2011-12

2011

DESIGN OF MACHINE ELEMENTS

Time Allotted : 3 Hours

Full Marks : 70

The figures in the margin indicate full marks.

Candidates are required to give their answers in their own words as far as practicable.

GROUP – A

(Multiple Choice Type Questions)

1. Choose the correct alternatives for any *ten* of the following : 10 × 1 = 10

- i) A turn buckle has
 - a) R.H thread at both ends
 - b) L.H thread at both ends
 - c) L.H thread at one end and R.H thread at other end
 - d) thread at the middle section.

- ii) The efficiency of a self locking squared threaded power screw is
 - a) more than 50%
 - b) equal to 50%
 - c) less than 50%
 - d) equal to 100%.



- iii) A spring used to absorb shock and vibration is
- a) closely coiled helical spring
 - b) open coiled helical spring
 - c) conical spring
 - d) torsion spring.
- iv) A welded joint is shown in Figure 1 :

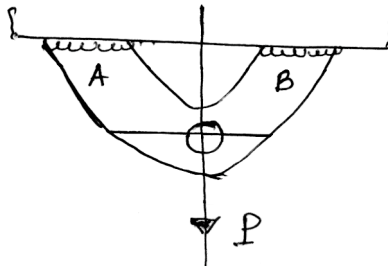

Figure 1

If the weld at *B* has thicker fillets than at *A*, the load carrying capacity, *P* of the joint will

- a) increase
 - b) decrease
 - c) remain unaffected
 - d) be doubled.
- v) When a nut is tightened by placing a washer below oil, the bolt will be subjected to
- a) tension
 - b) compression
 - c) shear
 - d) combined load.
- vi) Principal stress theory of failure is applicable for
- a) Ductile materials
 - b) Brittle materials
 - c) Metals
 - d) Composites.
- vii) The included angle in Acme thread is
- a) 60°
 - b) 55°
 - c) 47.5°
 - d) 29° .



3. a) What is meant by 'hole basis system' ?
- b) A hole is dimensioned as $25_{+0.03}^{-0.03}$ mm and the shaft is dimensioned as $25_{+0.00}^{-0.02}$ mm. Determine the hole tolerance and allowance of the fit. What type of fit will be established ? 2 + 3
4. a) What is the difference between stresses in thin and thick cylinders ?
- b) A thin cylindrical pressure vessel of 500 mm diameter is subjected to an internal pressure of 2 N/mm^2 . If the thickness of the vessel is 20 mm, find the hoop stress, longitudinal stress and the maximum shear stress. 2 + 3
5. A steam boiler, 1.2 metre in diameter, generates steam at a gauge pressure of 0.7 N/mm^2 . Assuming the efficiency of the riveted joints as 75%, find the thickness of the shell. Given that ultimate tensile stress = 385 MPa and factor of safety = 5.
6. In belt drive, for maximum power transmission, show that one third of the maximum tension in the belt is absorbed as centrifugal tension.



GROUP – C

(Long Answer Type Questions)

Answer any *three* of the following. $3 \times 15 = 45$

7. a) Design a helical spring for a spring loaded safety valve for the following conditions :

Operating pressure = 1 N/mm^2

Maximum pressure when the valve is blown off freely = 1.075 N/mm^2

Maximum lift of the valve when the pressure is $1.075 \text{ N/mm}^2 = 6 \text{ mm}$

Diameter of the valve seat = 100 mm

Maximum shear stress = 400 N/mm^2

Modulus of rigidity = $86 \times 10^3 \text{ N/mm}^2$

Spring index 5.5. 8

- b) A solid circular shaft is subjected to a bending moment of 3000 N-m and a torque of 10000 N-m . The shaft is made of 45C8 steel having ultimate tensile stress of 700 MPa and an ultimate shear stress of 500 MPa . Assuming a factor of safety as 6, determine the diameter of the shaft. 7



8. A line shaft supporting two pulleys A and B is shown in

Figure 2. Power is supplied to the shaft by means of a vertical belt on pulley A, which is then transmitted to pulley B carrying a horizontal belt. The ratio of belt tensions on tight and loose sides is 3 : 1 and the maximum tension in either belt is limited to 2.7 kN. The shaft is made of plain carbon steel 40C8 ($\sigma_{ut} = 650$ MPa and $\tau_{yt} = 380$ MPa). The pulleys are keyed to the shaft. Determine the shaft diameter according to A.S.M.E. code if $k_b = 1.5$ and $k_t = 1.0$.

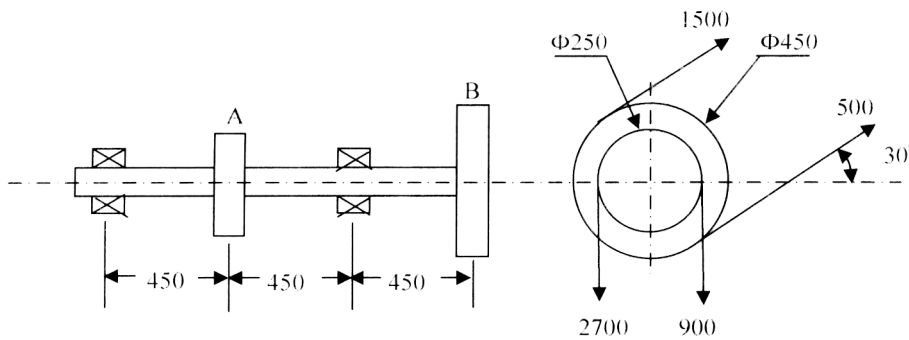

Lengths and forces indicated are in mm and N respectively.

Figure 2

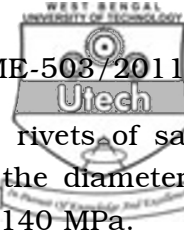

9. a) A bracket is supported by means of 4 rivets of same size, as shown in Figure 3. Determine the diameter of the rivet if the maximum shear stress is 140 MPa. 8

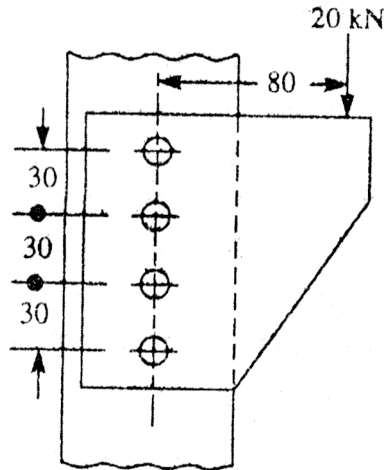

All dimensions in mm.

Figure 3

- b) Design of a cotter joint to connect a piston rod to the cross head. σ , the maximum steam pressure on the piston rod is 35 kN. Assuming that all the parts are made of the same material having the following permissible stresses :

Tensile stress = 100 N/mm^2 , Shear stress = 80 N/mm^2
and Crushing stress = 120 N/mm^2 . 7

10. Select a flat belt to drive a compressor running at 720 rpm which is driven by a 25 kW, 1440 rpm motor. Centre distance between the pulleys is 3 m. The belt is open type. The load correction factor is 1.3 and arc of contact factor 1.019. Dunlop's HI-SPEED belt rate is 0.0118 kW/mm width at 5.08 m/s belt velocity. Give the belt specification.



11. a) A 50 mm diameter solid shaft is welded to a flat plate as shown in Figure 4. If the size of the weld is 15 mm, find the maximum and normal shear stress in the weld. 7

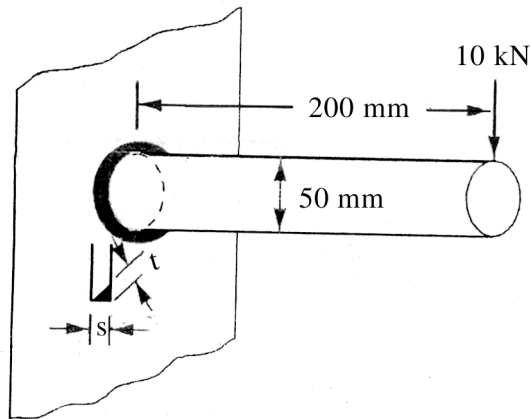

Figure 4

- b) A vertical two start square threaded screw of 100 mm mean diameter and 20 mm pitch supports a vertical load of 20 kN. The axial thrust on the screw is taken by a collar bearing of 250 mm outside diameter and 100 mm inside diameter. Find the force required at the end of a lever which is 400 mm long in order to lift and lower the load. The coefficient of friction between the screw and its nut is 0.15 and that for collar bearing is 0.20. 8

