

**I B. Tech I Semester Regular Examinations, January - 2020**  
**ENGINEERING DRAWING**  
 (Com. to CSE, IT, Agri E)

Time: 3 hours

Max. Marks: 75

**Answer any five Questions one Question from Each Unit**  
**All Questions Carry Equal Marks**

1. a) Draw an involute of a circle of diameter 40 mm diameter. Also draw the normal and tangent to the curve at a point 80 mm from the center of the circle. (10M)

b) Construct a regular heptagon of side 40 mm. (5M)

Or

2. a) Construct a vernier scale to read meters, decimeters, and long enough to measure up to 6 meters when 1 meter is represented by 2.5 centimeters. Find R.F and show on it, a distance of 4.33 meters. (8M)

b) Construct an ellipse of vertical major axis 90 mm and horizontal minor axis 60mm long. (7M)

3. End A of the line AB of 75mm long is 50mm in front of VP and 15mm above HP. End B is 15mm in front of VP and above HP. Top view of the line is measured to be 50mm long. Determine the front view length and the true inclination. Show also its traces. (15M)

Or

4. a) Two points A and B are in the Horizontal Plane. The point A is 30mm in front of VP, while B is behind the VP. The Distance between their projectors is 75mm and the line joining their top views makes an angle  $45^{\circ}$  with xy. Find the distance of the point B from the VP. (7M)

b) (i) Draw the projections of a line 70mm long when it is perpendicular to HP and parallel to VP and 15mm in front of VP. (8M)  
 (ii) A line 70mm long is perpendicular to VP and parallel to HP and 20mm above it. Draw its projections.

5. A hexagonal lamina of side 30 mm rests on one of its corner on VP the diagonal containing the corner inclined  $50^{\circ}$  to HP. The surface of the lamina is inclined  $35^{\circ}$  to VP. Draw its projection. (15M)

Or

6. A pentagonal lamina of 40 mm side has an edge on the HP. The surface of the plane is Inclined at  $45^{\circ}$  to HP and perpendicular to the VP. Draw its projections. (15M)

7. a) Draw the projection of a cone of diameter 40 mm and height 70 mm lying on the ground on one of its base point such that base makes an angle  $40^{\circ}$  to HP. and perpendicular to VP. (10M)

b) A pentagonal pyramid of 30 mm side and axis 60 mm long is resting upon its base on HP such that one of the base edges is perpendicular to VP. If the axis of the pyramid is parallel to and 40 mm away from VP. Draw its projections. (5M)

Or

8. A Hexagonal Prism of side of base 35 mm and length of axis 70 mm has a side of base parallel to the HP. The axis of the prism is inclined at  $30^\circ$  to the HP and  $45^\circ$  to the VP. Draw the projection of Prism. (15M)
9. Figure.1 shows the three views of an object. Draw the isometric view. (15M)

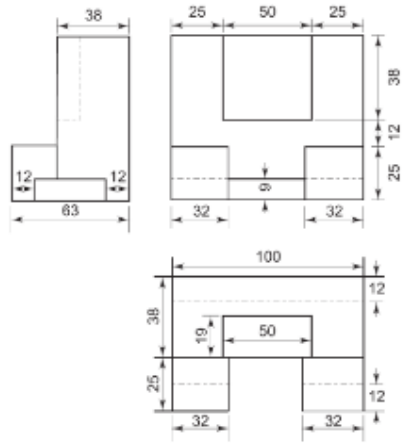

Figure.1

Or

10. Draw the front, top and left and right hand side view of the given figure.2. (15M)

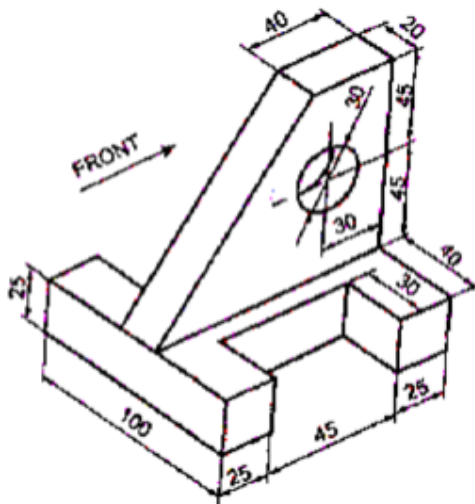

Figure.2



**I B. Tech I Semester Regular Examinations, January - 2020**  
**ENGINEERING DRAWING**  
 (Com. to CSE, IT, Agri E)

Time: 3 hours

Max. Marks: 75

**Answer any five Questions one Question from Each Unit**  
**All Questions Carry Equal Marks**

- ~~~~~
1. a) Construct an epicycloids having a rolling circle of diameter 50 mm and a directing circle of radius 100mm. Also draw a tangent and normal at any point M on the curve. (10M)
  - b) Construct a regular hexagon and octagon of each of side of length 40mm by general method. (5M)

Or

2. a) The major axis of an ellipse is 130 mm and the minor axis is 80mm long. Find the foci and draw the ellipse by arcs of circles method. Draw a tangent to the ellipse at a point on it 25mm above the major axis. (7M)
- b) On a map, the distance between two points is 14 cm. The real distance between them is 20 km. Draw a diagonal scale of this map to read kilometres and hectametres, and to measure up to 25km. Show a distance of 17.6 km on this scale? (8M)
3. a) Two points F and G are on HP. The point F being 15 mm in front of VP, while G is 20 mm behind VP. The line joining their top views makes an angle of  $45^{\circ}$  with xy. Find the horizontal distance between two points. (7M)
- b) A 100 mm long line is parallel to and 40 mm above HP. Its two ends are 25 mm and 50 mm in front of the VP respectively. Draw its projections and find its inclination with the VP. (8M)

Or

4. The line AB has its end A 10 mm in front of VP and 15 mm above the HP, end B 35 mm in front of VP and 40 mm above the HP. The distance between the end projectors is 55 mm. Draw the projection of line and find out its true length, inclination with HP and VP. Also locate the HT and VT. (15M)
5. A thin circular plate of 45 mm diameter with its center 35 mm above HP and 40 mm in front of VP is perpendicular to VP and inclined to HP at angle of  $30^{\circ}$ . Draw the projections of the plate. (15M)

Or

6. A square lamina ABCD of side 45 mm rests on the ground on its corner A in such a way that the diagonal AC is inclined at  $45^{\circ}$  to the HP and apparently inclined at  $30^{\circ}$  to the VP. Draw its projections. (15M)
7. a) A square prism, base 40mm side and height 65mm, has its axis inclined at  $45^{\circ}$  to the HP and has an edge of its base on the HP. Draw its projections. (10M)
- b) A Hexagonal pyramid, side of base 25 mm and axis 55 mm long rests with one of the edges of its base on HP. Draw its Projections. (5M)

Or

8. A square pyramid of base 40 mm and height 60 mm is on HP with one of its base edges so that the axis is making  $45^{\circ}$  with HP and the base edge making  $30^{\circ}$  with VP. Draw the projections. (15M)
9. The front and top views of an object are shown in figure.1. Construct the isometric view. (15M)

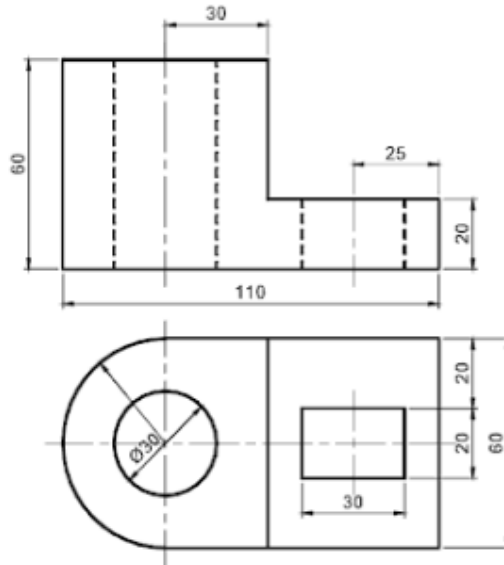

Figure.1

Or

10. Draw the three orthographic views for the following figure.2. (15M)

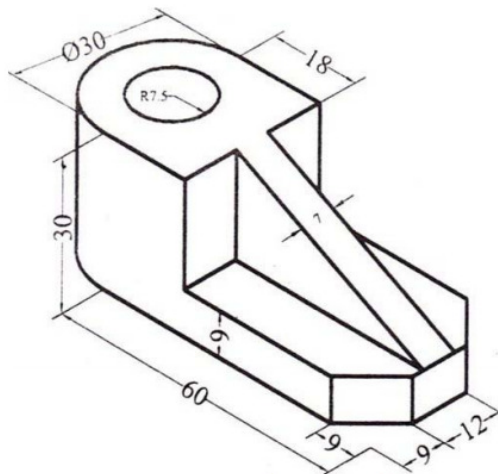

Figure.2



**I B. Tech I Semester Regular Examinations, January - 2020**  
**ENGINEERING DRAWING**  
 (Com. to CSE, IT, Agri E)

Time: 3 hours

Max. Marks: 75

**Answer any five Questions one Question from Each Unit**  
**All Questions Carry Equal Marks**

1. a) Construct a cycloid given the radius of the generating circle is 30 mm. Also draw a tangent and normal at any point on the cycloid. (10M)

b) Divide a straight line AB of 60mm long into eight number of equal parts. (5M)

Or

2. a) Draw a rectangular hyperbola. Given a point P on it as 25 mm and 35 mm from the asymptotes OX and OY respectively. Also draw a tangent and normal at any point M on the curve. (7M)

b) An area of 144 Sq. cm on a map represents an area of 9 Sq. km on the field. Find the R.F. of the scale for this map and draw a diagonal scale to show kilometers, hectametres and decameters and to measure upto 5 kilometres. Indicate on the scale a distance of 3 kilometres, 5 hectametres and 6 decametres. (8M)

3. a) A line AB is on HP and its one end A is 20mm in front of VP The line makes an angle of  $45^{\circ}$  with VP and its front view is 60 mm long. Draw the projections of the line and determine the true length. (8M)

b) A point A is 30 mm above the HP and 8mm in front of VP. The point B is 10 mm above the HP and 25 mm in front of VP. The distance between the projectors of A and B is 50 mm. Determine the traces of the line joining A and B. (7M)

Or

4. A and B are two points space. The point A is in the VP and 24 mm above the HP. Point B is in the HP and 36 mm from the VP. The point A is 54 mm away from B. Draw the top view and front view of the straight line AB and also determine the true inclinations of the line with HP and VP respectively. (15M)

5. A circular lamina of diameter 40 mm rests on one of its circumference point on HP. the diameter containing the point inclined  $45^{\circ}$  to VP. The surface of the lamina is inclined  $40^{\circ}$  to HP. Draw its projection. (15M)

Or

6. A regular hexagon of 40 mm side has a corner in the HP. Its surface inclined at  $45^{\circ}$  to the HP. and the top view of the diagonal through the corner which is in the HP. makes an angle of  $60^{\circ}$  with the VP. Draw its projections. (15M)



7. a) A hexagonal prism of base side 25 mm and axis height 55 mm resting on HP with one of its base edges, such that, the axis is inclined at  $30^\circ$  to HP and parallel to VP. Draw the projections of the prism. (10M)
- b) A square pyramid, side of 35 mm and axis 55 mm is resting on HP. Draw its projections when all the sides of the bases equally inclined to VP. (5M)

Or

8. A pentagonal pyramid has an edge of the base in the VP and inclined at  $30^\circ$  to the HP, while triangular face containing that edge makes an angle of  $45^\circ$  with the VP. Draw the three views of the pyramid. Length of side of the base is 30 mm, while that of the axis is 65 mm. (15M)
9. Draw the three orthographic views for the following figure.1. (15M)

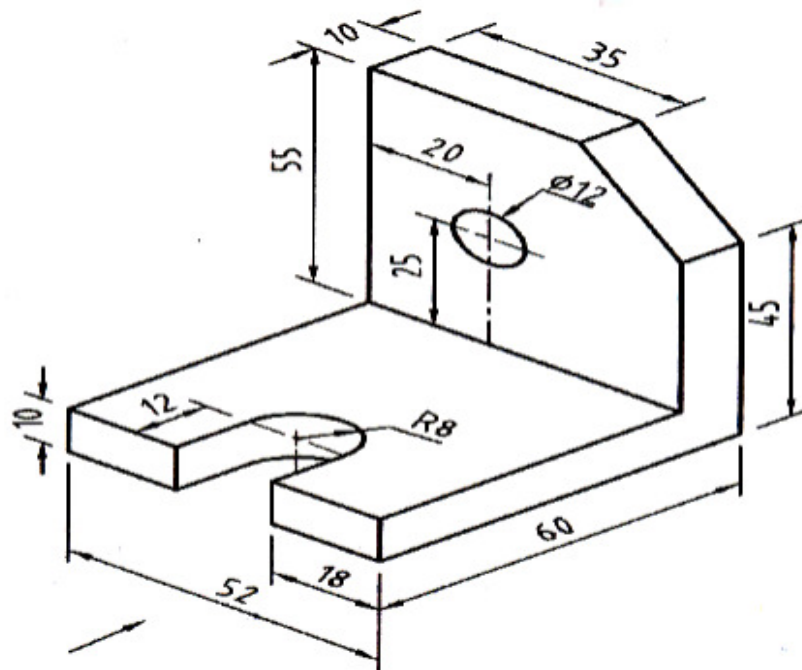

Figure.1

Or

10. Plan, elevation and side view of a cut block is given in figure.2. Construct the isometric view. (15M)

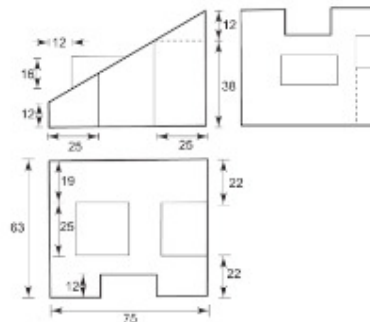

Figure.2



**I B. Tech I Semester Regular Examinations, January - 2020**  
**ENGINEERING DRAWING**  
 (Com. to CSE, IT, Agri E)

Time: 3 hours

Max. Marks: 75

**Answer any five Questions one Question from Each Unit**  
**All Questions Carry Equal Marks**

1. a) Construct a diagonal scale of Representative Fraction is  $1/4000$  to show meters (8M)  
 and long enough to measure up to 500 meters. Show on a distance of 374 meters  
 and 153 meters.

b) Draw a rectangle having its sides 125 mm and 75 mm long. Inscribe a parabola in (7M)  
 it.

Or

2. a) Construct a scale of R.F=  $1:2.5$  to show decimeters and centimeters and by a (8M)  
 vernier to read millimeters to measure up to 4 decimeters. Mark on the scale  
 lengths of 2.26 dm.

b) Construct a regular pentagon of 40 mm side by any two methods. (7M)

3. a) A line 50mm long is inclined at  $45^\circ$  to the VP. It is parallel to HP. and 20 mm (7M)  
 above it. Draw its elevation.

b) Draw the projection of following points. Give 30mm space between each (8M)  
 projectors with proper dimensions.

(i) A is 35 mm above HP and 45 mm in front of VP.

(ii) B is 40 mm above HP and in VP.

(iii) C is in HP and 45 mm in front of VP.

(iv) D is in both HP and VP.

Or

4. A straight line PQ has its end P 15mm in front of the VP and nearer to it. The mid (15M)  
 point M of the line is 55 mm in front of the VP and 45 mm above the HP. The  
 front and top views measure 95mm and 110mm respectively. Draw the projections  
 of the line. Also find its true length and true inclinations with the HP and the VP.

5. A semi-circular plate of 80mm diameter has its straight edge in the VP and (15M)  
 inclined at  $45^\circ$  to the HP. The surface of the plate makes an angle of  $30^\circ$  with the  
 VP. Draw its projections.

Or

6. Draw the projections of pentagonal lamina whose side is 30mm long, which is rest (15M)  
 on HP by one of its edge and inclined at  $45^\circ$  to VP. The surface of the plate is  
 inclined at  $30^\circ$  to HP.

7. a) A pentagonal prism, edge of base 30 mm and axis length 60 mm has one of its of (10M)  
 the base in the VP. Draw its projections if rectangular face containing that edge  
 makes an angle  $30^\circ$  with the VP.

b) Draw the projections of a tetrahedron with 65mm long edges lying on a face in the (5M)  
 HP. and an edge of the face is perpendicular to the VP.

Or



8. A right circular cone of base 60mm diameter and axis 75mm long is lying on VP (15M) on one of its end generator. Draw projections of the cone when F.V. of an axis inclined at  $45^\circ$  with the HP.
9. Draw the front, top and left and right hand side view of the given figure.1 (15M)

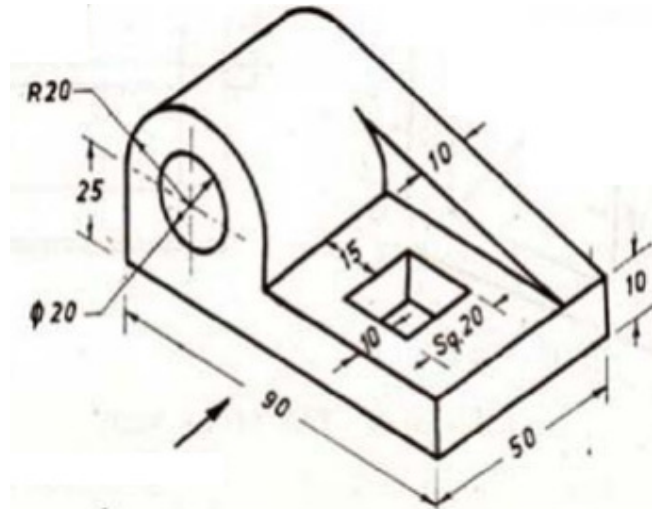

Figure.1

Or

10. Construct the isometric view from the following views as shown in figure.2. (15M)

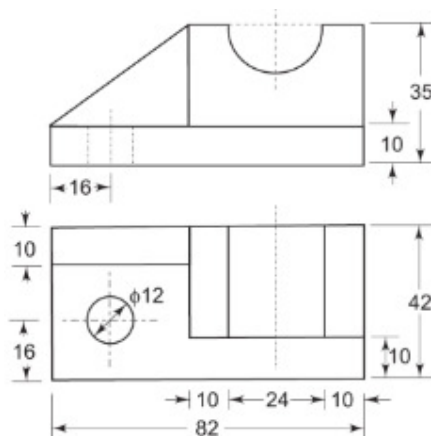

Figure.2

