

SE | COMP | III (R.)

EDLC

13/5/13

P4-RT-Exam.-Feb.-13-2-275

Con. 6402-13.

GS-6195

(3 Hours)

[Total Marks : 100

N.B. : (!) Question No. 1 is compulsory.

(2) Attempt any **four** questions out of the remaining **six** questions.

(3) **Figures** to the **right** indicates **full** marks.

(4) Assume **suitable** data wherever **necessary** and mention it clearly.

1. (a) Explain the purpose of thin and lightly doped base region of BJT structure. 5

(b) List the characteristic features of 555 timer. 5

(c) Design a circuit with OP-AMP to produce the O/P  $V_0$  given by - 5

$$V_0 = (V_{s1} + V_{s3}) - (V_{s2} + V_{s4})$$

(d) Justify how FET can be used as variable resistor, constant source and constant voltage source. 5

2. (a) Explain the graphical determination of the h-parameters using characteristic curve of CE amplifier. 10

(b) Determine the following for the circuit shown in figure :- 10

(i)  $I_{BQ}$  (ii)  $I_{CQ}$  (iii)  $V_{CEQ}$  (iv)  $V_{CQ}$  (v)  $V_{EQ}$  (vi)  $V_{BQ}$

Use exact and approximate analysis to solve the same.

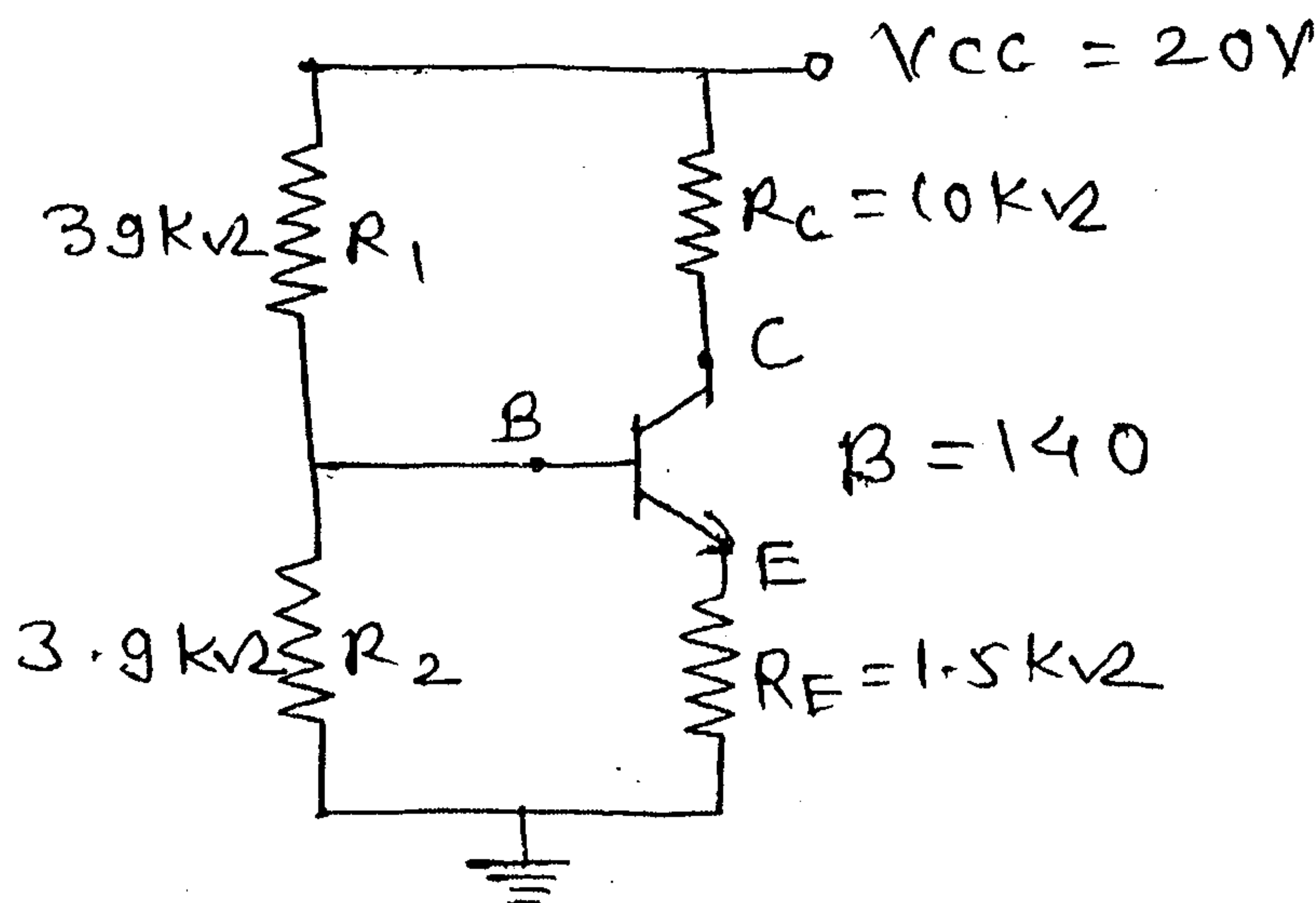

[TURN OVER

3. (a) Derive equations for  $Z_i$ ,  $Z_o$ ,  $A_v$ , for common source configuration using voltage divider network (with unbypassed  $R_s$ ). 10
- (b) Calculate the voltage gain, input and O/P impedance for the circuit shown below:- 10

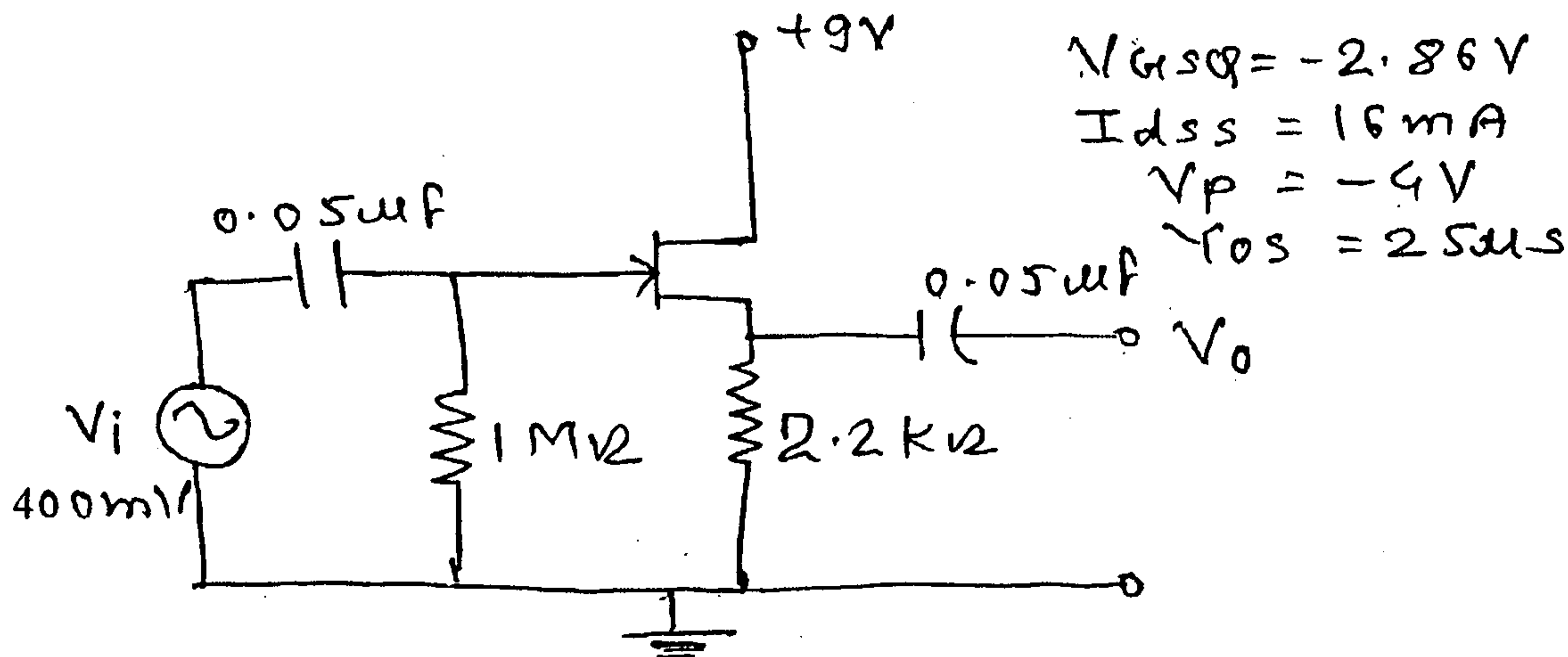

4. (a) Explain any two applications of monostable multivibrator using IC 555. 10
- (b) Design a regulator using LM 723 for  $V_o = 9V$  and  $I_o = 3A$ . 10
5. (a) Explain the D/A converter using binary weighted resistor. 10
- (b) Explain how an op-amp can be used as - (i) Integrator, (ii) Differentiator. 10
6. (a) Explain Instrumentation amplifier with three OP-AMPS and derive overall gain  $A_v$ . 10
- (b) Using IC 555 design Astable multivibrator for output frequency at 5 kHz and duty cycle of 70%. Draw the related waveforms. 10
7. Write short notes on (any four) :- 20
- Virtual ground concept of OP-AMP
  - Inverting Schmitt Trigger
  - Properties of Ideal OP-AMP
  - PLL
  - Zero crossing detector.