

**6E3109**

Roll No. \_\_\_\_\_

[Total No. of Pages : 4]

**6E3109****B.Tech. VIth Semester (Main/Back) Examination, June - 2010****Electrical Engineering****6 EE1 Modern Control Theory (Common for EE & EX)****Time : 3 Hours****Maximum Marks : 80****Min. Passing Marks : 24****Instructions to Candidates:**

*Attempt overall Five questions selecting one question from each unit. All questions carry equal marks. (Schematic diagrams must be shown wherever necessary. Any data you feel missing may suitably be assumed and stated clearly. Units of quantities used/calculated must be stated clearly.)*

*Use of following supporting material is permitted during examination. (Mentioned in form No. 205)*

1. Calculator.

**Unit-I**

1. a) Define linear, independence of vectors. What information do they give about the controllability of the system. Define
  - i) Bases
  - ii) Domain
  - iii) Range of a vector space. (8)
- b) How is Linearity defined in reference of a control system. Can a nonlinear system be linearised? Which techniques do you know? (8)

**OR**

- a) Differentiate between Modern and conventional control system. (8)
- b)
  - i) What is meant by causal and non-causal systems.
  - ii) Define state, state space and state space equations. (8)

## Unit-II

2. a) Obtain the state space representation for the following mechanical system. (8)

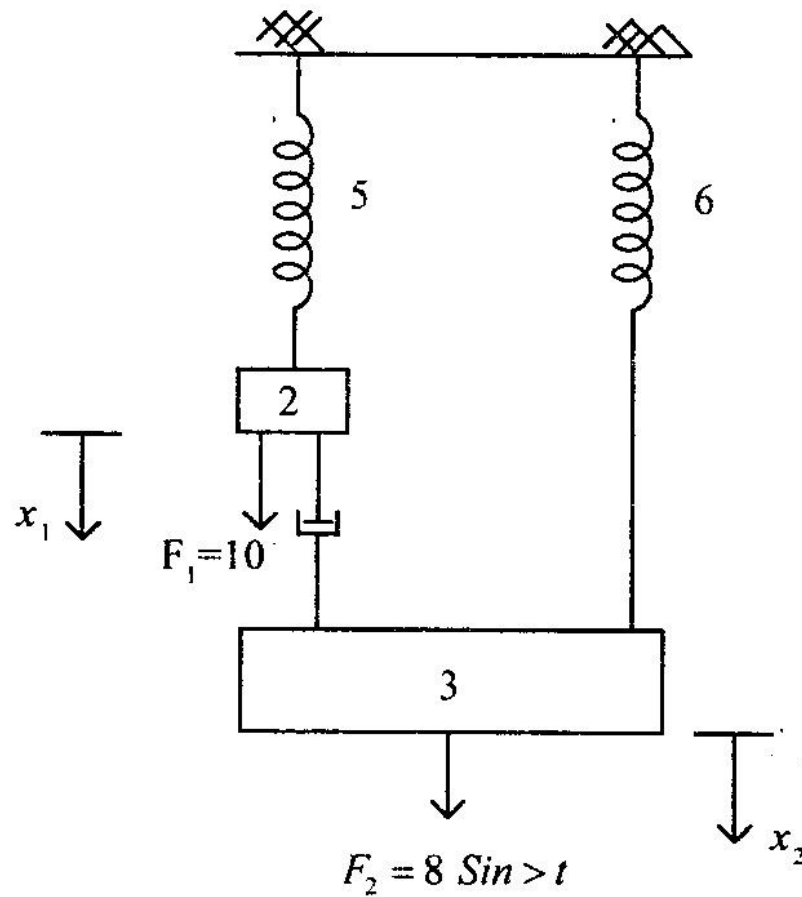

- b) Write differential equations governing the following electrical circuit and hence develop transfer function for it. (8)

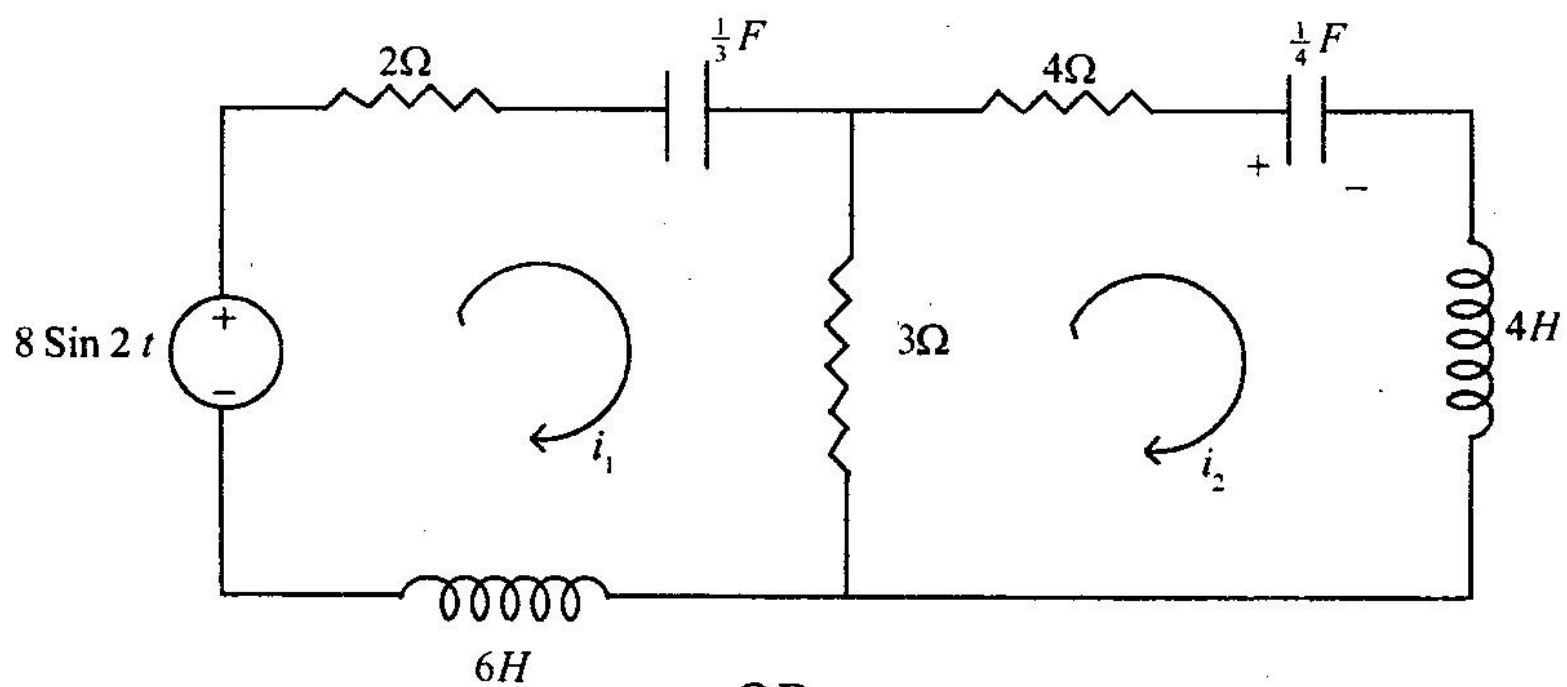

OR

- a) A system is described by following differential equation. Derive the state model for it.

$$\frac{d^3 y}{dt^3} + 6 \frac{d^2 y}{dt^2} + 2 \frac{dy}{dt} + 4y = -5 \frac{d^2 u}{dt^2} + 8 \frac{du}{dt} \quad (6)$$

- b) Show that systems shown in figures below are analogous systems. Find the transfer functions of both.

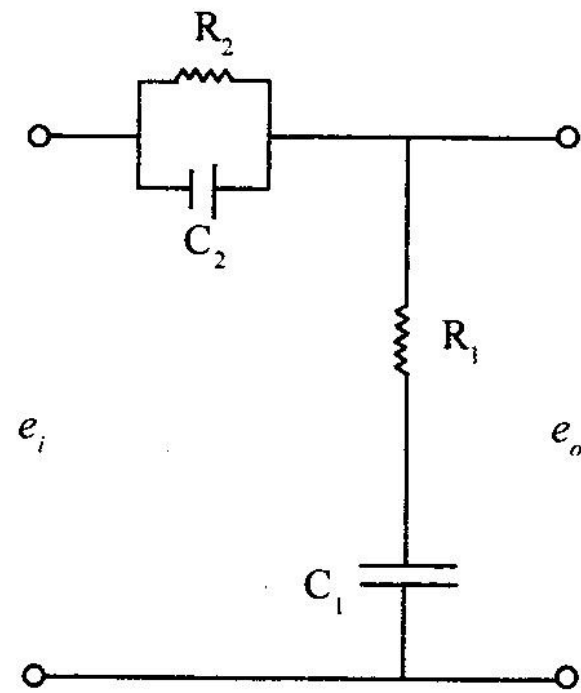
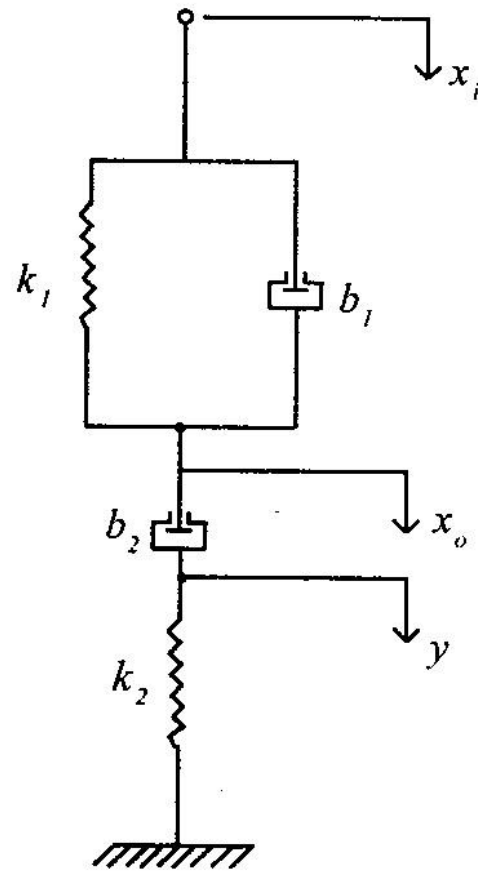

(10)

**Unit-III**

3. a) A control system is described by following transfer function.

$$\frac{Y(s)}{U(s)} = \frac{s+12}{s^2+7s+12}$$

obtain the state space representation of this system in

- i) Controllable phase variable form.
- ii) Observable phase variable form.

(8)

- b) Consider the system

$$\dot{x} = \begin{bmatrix} 0 & 1 \\ -2 & -3 \end{bmatrix} X, \quad X(0) = \begin{bmatrix} 0 \\ 1 \end{bmatrix}$$

Find the free response of the system. (8)

**OR**

- a) Consider the system

$$\dot{X} = \begin{bmatrix} -3 & 1 \\ -2 & 0 \end{bmatrix} X + \begin{bmatrix} 0 \\ 1 \end{bmatrix} Y$$

$$Y = [1 \ 0] X.$$

Find the transfer function  $\frac{C(s)}{R(s)}$  of the above system. (8)

- b) Consider the same system given in the above equation. Transform the

system by similarity transformation defined by  $X = P \bar{X} = \begin{bmatrix} 2 & -1 \\ -1 & 1 \end{bmatrix} \bar{X}$ . (8)

#### Unit-IV

4. a) For the system matrix

$$A = \begin{bmatrix} -4 & 1 & 0 \\ 0 & -3 & 1 \\ 0 & 0 & -2 \end{bmatrix} \text{ Find the eigenvalues and eigenvectors.} \quad (8)$$

- b) Write short notes on : (any two)

- i) State transition matrix
- ii) Caley - Hamilton Theorem
- iii) Kalman's method of controllability and observability. (4 each)

OR

- a) The transfer function  $G(s)$  of a system is given by  $G(s) = \frac{s+3}{(s+2)^2(s+5)}$ .

Transform the system in Jordan canonical form. (8)

- b) Write short notes on : (any two)

- i) Pole - placement Design
- ii) Eigenvalues & Eigenvectors
- iii) Solution of state equation. (4each)

#### Unit-V

5. a) Consider the system  $\dot{X} = AX + BY$  and  $Y = CX$  with

$$A = \begin{bmatrix} 0 & 1 \\ 0 & 0 \end{bmatrix} \quad b = \begin{bmatrix} 0 \\ 1 \end{bmatrix} \quad \text{and} \quad c = [1 \quad 0]$$

Design a feedback control law to place the closed loop poles at  $s = -4 \pm j4$ . (8)

- b) How are digital control systems different from continuous time control systems. How are they analysed and what stability tests are available to check their stability. (8)

OR

Write short notes on : (any two)

- i) Ackerman's Formula.
- ii) Sampled data control systems.
- iii) Digital PID controller. (8each)