

N.B: (1) Question no 1 is compulsory.

- (2) Answer any **four** out of remaining six Questions.
- (3) Assume any **suitable** data wherer **required**.
- (4) **Weightage** will be given to **neat presentation** and **neat sketches**.
- (5) **Figures** in bold to the right indicate **full marks**.

1. Answer any four question

(20)

- A) Prove that the sensitiveness of a proell governor is greater than that of a porter governor.
- B) Explain the term self locking and self energizing brakes.
- C) Explain with neat diagram teas used in the radial cams.
 - I. Base circle.
 - II. Trace point.
 - III. Pressure angle.
 - IV. Pitch point.
 - V. Pitch circle.
- D) Derive the equation of gyroscopic couple on naval ship during pitching.
- E) Explain epicyclic gear train with it's merits & demerits' as companied to reverted gear train.
- F) Find the relation for frictional torque acting on the centrifugal clutch.

2. A) In the epicyclic gear train as shown in fig, the compound wheel A & B as well as internal wheel C & D rotate independently about the axis 'o'. the wheels E & F rotate on the pins fixed to arm A .all the wheels are of same module the number of teeth on the wheels are ,

$T_A=52; T_B=56; T_E \& T_F=36$; deter mine the speed of C if

- I. The wheel D fixed and arm A rotates at 200 rpm clockwise
- II. The wheel D rotates at 20 rpm counter- clockwise & the arm A rotates at 200rpm clockwise

(14)

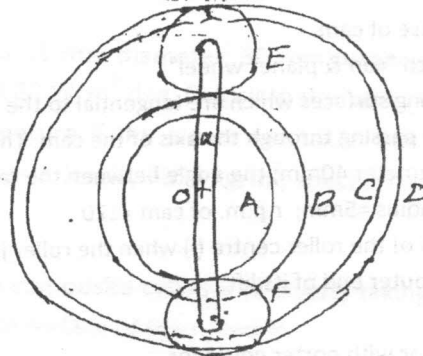

B) Explain with neat sketch the working of epicyclic-train dynamometer (06)

3. A) Explain with neat sketches the steering, pitching, and rolling related to naval ship (06)

B) All the arms of a porter governor are 178 mm long and are hinged at a distance of 38mm from the axis of rotation .the mass each ball is 1.15kg and mass of the sleeve is 20kg.The governor sleeve begins to rise at 280 rpm when the links are at an angle 30° to the vertical. Assuming the friction force to be constant, determine the minimum and maximum speed of rotation when the inclination of the arms to the vertical is 45° .

(14)

4. A) A cone clutch transmits 20kW at 1600 rpm .the following data apply; Cone angle $=30^\circ$; maximum intensity of pressure $=0.8 \times 10^5 \text{ N/m}^2$; the mean radius is twice the width of the friction surface. Co-efficient of friction is 0.3 .Determine (i) the dimensions of the contact surfaces. (ii)The axial load or force to keep the clutch engaged when transmitting power. (iii) The width of the friction surface. Assume uniform wear. (14)

B) Define and Explain the following terms relating to governor, (08)

- I. Sensitiveness.
- (ii) Isochronous.

5. A) The drum for a band brake of a crane is 50cm diameter, The crane barrel is 35 cm diameter, the angle of contact of band brake 280° and the co-efficient of friction between the band and the drum is 0.25. The brake lever is arranged as shown in Fig. Calculate the force P required to support a load of 10,000N on the rope round the barrel.

(12)

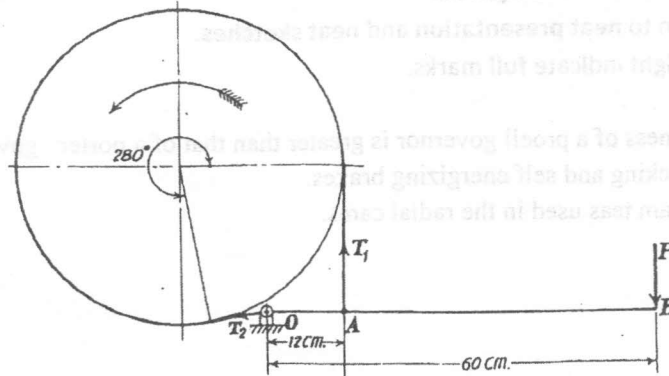

- B) Prove that the frictional torque in case of cone clutch considering uniform wear is given by,

(08)

$$T_{total} = \frac{1}{2} \times \mu w (r_1 + r_2) / \sin \alpha$$

6. A) A motor cycle with rider has a mass of 250kg. The centre of gravity of the motor cycle and the rider falls 60cm above the ground when running straight in vertical position. Each road wheel diameter is 60cm with polar mass moment of inertia of 1 kgm^2 . The engine rotates 6 times faster than the wheels in the same direction and the rotating parts of the engine have a mass moment of inertia of 0.175 kgm^2 . Determine the angle of inclination of the motor cycle or the angle of heel required if it is speeding at 80km/hr and rounding a curve of radius 50m.

(12)

- B) Explain the following.

(08)

- I. Jump phenomena in case of cam.
- II. Explain with neat sketch "sun & planet wheel"

7. A) A cam has straight working surfaces which are tangential to the base circle of the cam. The follower is a roller follower with line of stroke passing through the axis of the cam. The particulars are the following Base circle diameter=90mm; Roller diameter 40mm; the angle between the tangential faces of cam $=90^\circ$; The faces are joined by a nose circle of radius =5mm; r.p.m. of cam =120. Determine the acceleration of the roller centre (i) when the roller just leaves contact of the flank on its ascent (ii) when the roller is at its outer end of its lift.

(16)

- B) compare the watt governor with porter governor.

(04)