

**10EE63 ELECTRICAL MACHINE DESIGN**

Subject Code : 10EE63 IA Marks : 25

No. of Lecture Hrs./ Week : 04 Exam Hours : 03

Total No. of Lecture Hrs. : 52 Exam Marks : 100

**PART -A****UNIT-1**

**PRINCIPLES OF ELECTRICAL MACHINE DESIGN:** Introduction, considerations for the design of electrical machines, limitations. Different types of materials and insulators used in electrical machines. 4 Hours

**UNIT-2**

**DESIGN OF DC MACHINES:** Output equation, choice of specific loadings and choice of number of poles, design of Main dimensions of the DC machines, Design of armature slot dimensions, commutator and brushes, magnetic circuit -estimation of ampere turns, design of yoke and poles-main and inter poles, field windings – shunt, series and inter poles. 10 Hours

**UNIT -3 & 4**

**DESIGN OF TRANSFORMERS** (Single phase and three phase): Output equation for single phase and three phase transformers, choice of specific loadings, expression for volts/turn, determination of main dimensions of the core, types of windings and estimation of number of turns and conductor cross sectional area of Primary and secondary windings, estimation of no load current, expression for leakage reactance and voltage regulation. Design of tank and cooling tubes (round and rectangular) 12 Hours

**PART -B****UNIT -5 & 6**

**DESIGN OF INDUCTION MOTORS:** Output equation, Choice of specific loadings, main dimensions of three phase induction motor, Stator winding design, choice of length of the air gap, estimation of number of slots for the squirrel cage rotor, design of Rotor bars and end ring, design of Slip ring induction motor, estimation of No load current and leakage reactance, and circle diagram. 14 Hours

**UNIT -7 & 8**

**DESIGN OF SYNCHRONOUS MACHINES:** Output equation, Choice of specific loadings, short circuit ratio, design of main dimensions, armature slots and windings, slot details for the stator of salient and non salient pole synchronous machines. Design of rotor of salient pole synchronous machines, magnetic circuits, dimensions of the pole body, design of the field winding, and design of rotor of non-salient pole machine. 12 Hours

**TEXT BOOKS:**

1. A Course In Electrical Machine Design, A.K.Sawhney,Dhanpatt Rai & Sons
2. Design Of Electrical Machines, V. N. Mittle, 4th edition

**REFERENCE BOOKS:**

1. Performance And Design Of AC Machines, M.G.Say,CBS Publishers and Distributors Pvt.Ltd.
2. Design Data Handbook, A.Shanmugasundarm, G,Gangadharan,R.Palani,Wiley Eastern Ltd.

## CONTENT

SL No	TOPIC	Page No
1	<b>UNIT 1: PRINCIPLES OF ELECTRICAL MACHINE DESIGN</b>	<b>6-13</b>
2	<b>Introduction, considerations for the design of electrical machines.</b>	
3	<b>Limitations.</b>	
4	<b>Different types of materials.</b>	
5	<b>Insulators used in electrical machines.</b>	
6	<b>UNIT 2 DC Machines</b>	<b>14-66</b>
7	<b>Output equation, choice of specific loadings and choice of number of poles.</b>	
8	<b>design of Main dimensions of the DC machines.</b>	
9	<b>Design of armature slot dimensions.</b>	
10	<b>Commutator and brushes.</b>	
11	<b>Magnetic circuit.</b>	
12	<b>Estimation of ampere turns.</b>	
13	<b>Design of yoke and poles-main and inter poles.</b>	
14	<b>Field windings – shunt,</b>	
15	<b>series and</b>	
16	<b>inter poles.</b>	

17	<b>UNIT 3 &amp; 4 DESIGN OF TRANSFORMERS</b>	<b>67-105</b>
18	<b>(Single phase and three phase): Output equation for single phase and three phase transformers,</b>	
19	<b>choice of specific loadings,</b>	
20	<b>expression for volts/turn,</b>	
21	<b>determination of main dimensions of the core,</b>	
22	<b>types of windings and estimation of number of turns and conductor cross sectional area of Primary and secondary windings, estimation of no load current,</b>	
23	<b>expression for leakage reactance and voltage regulation.</b>	
24	<b>Design of tank and cooling tubes (round and rectangular)</b>	
25	<b>UNIT 5 &amp; 6 DESIGN OF INDUCTION MOTORS: diagram</b>	<b>106-150</b>
26	<b>Output equation,</b>	
27	<b>Choice of specific loadings,</b>	
28	<b>choice of length of the air gap,</b>	
29	<b>estimation of number of slots for the squirrel cage rotor,</b>	
30	<b>design of Rotor bars and end ring,</b>	
31	<b>design of Slip ring induction motor,</b>	
32	<b>estimation of No load current and leakage</b>	

	<b>reactance and circle diagram.</b>	
<b>33</b>	<b>DESIGN OF SYNCHRONOUS MACHINES:</b>	<b>151-192</b>
<b>34</b>	<b>Output equation, Choice of specific loadings,</b>	
<b>35</b>	<b>short circuit ratio, design of main dimensions, armature slots and windings,</b>	
<b>36</b>	<b>slot details for the stator of salient and non salient pole synchronous machines.</b>	
<b>37</b>	<b>Design of rotor of salient pole synchronous machines,</b>	
<b>38</b>	<b>magnetic circuits, dimensions of the pole body,</b>	
<b>39</b>	<b>design of the field winding,</b>	
<b>40</b>	<b>and design of rotor of non-salient pole machine.</b>	

**UNIT-1**

**PRINCIPLES OF ELECTRICAL MACHINE DESIGN:** Introduction, considerations for the design of electrical machines, limitations. Different types of materials and insulators used in electrical machines. 4 Hours

**Electrical Machine Design****Chapter.1 PRINCIPLES OF ELECTRICAL MACHINE DESIGN****Introduction**

The magnetic flux in all electrical machines (generators, motors and transformers) plays an important role in converting or transferring the energy. Field or magnetizing winding of rotating machines produces the flux while armature winding supplies either electrical power or mechanical power. In case of transformers primary winding supplies the power demand of the secondary.

The basic design of an electrical machine involves the dimensioning of the magnetic circuit, electrical circuit, insulation system etc., and is carried out by applying analytical equations.

A designer is generally confronted with a number of problems for which there may not be one solution, but many solutions. A design should ensure that the products perform in accordance with the requirements at higher efficiency, lower weight of material for the desired output, lower temperature rise and lower cost. Also they are to be reliable and durable.

A practical designer must effect the design so that the stock (standard frames, punching etc.) is adaptable to the requirements of the specification. The designer must also affect some sort of compromise between the ideal design and a design which comply with manufacturing conditions. A electrical designer must be familiar with the,

- a. National and international standards
  - Indian Standard (IS), Bureau of Indian Standard (BIS), India
  - British Standard (BS), England
  - International Electrotechnical Commission (IEC)
  - NEMA (The National Electrical Manufacturers Association).
- b. Specifications (that deals with machine ratings, performance requirements etc., of the consumer)
- c. Cost of material and labour
- d. Manufacturing constraints etc.

A designer can refer to Design Data Handbook (Electrical Machine Design Data Book, authored by A Shanmugasundaram and others, New Age International Publishers, Reprint 2007, or any other such handbooks) which is a source of design procedure, properties of materials, ranges of design parameters etc., and manufacturer's brochure.

As the design involves a number of assumptions and constraints, final design values can be obtained only by iterative methods. Computer plays a vital role in arriving at the final values. By Finite Element Method (FEM), the effect of a single parameter on the dynamical performance of the machine can be studied. Furthermore, some tests, which are not even feasible in laboratory setup, can be virtually performed by Finite Element Method.

The design problems, that have been considered to solve in the latter chapters, are of different nature from the design worked out in detail in respect of any machine. However, these test problems provide adequate elementary skills in design, which is an indication that a student has a fair knowledge to deal with the entire design.

### Factors for consideration in electrical machine design

The basic components of all electromagnetic apparatus are the field and armature windings supported by dielectric or insulation, cooling system and mechanical parts. Therefore, the factors for consideration in the design are,

1. **Magnetic circuit or the flux path:** Should establish required amount of flux using minimum mmf. The core losses should be less.
2. **Electric circuit or windings:** Should ensure required emf is induced with no complexity in winding arrangement. The copper losses should be less.
3. **Insulation:** Should ensure trouble free separation of machine parts operating at different potential and confine the current in the prescribed paths.
4. **Cooling system or ventilation:** Should ensure that the machine operates at the specified temperature.
5. **Machine parts:** Should be robust.

The art of successful design lies not only in resolving the conflict for space between iron, copper, insulation and coolant but also in optimization of cost of manufacturing, and operating and maintenance charges.

The factors, apart from the above, that requires consideration are

- a. Limitation in design ( saturation, current density, insulation, temperature rise etc.,)
- b. Customer's needs
- c. National and international standards
- d. Convenience in production line and transportation
- e. Maintenance and repairs
- f. Environmental conditions etc.

### Limitations in design

The materials used for the machine and others such as cooling etc., imposes a limitation in design. The limitations stem from saturation of iron, current density in conductors, temperature, insulation, mechanical properties, efficiency, power factor etc.

- a. **Saturation:** Higher flux density reduces the volume of iron but drives the iron to operate beyond knee of the magnetization curve or in the region of saturation. Saturation of iron poses a limitation on account of increased core loss and excessive

- excitation required to establish a desired value of flux. It also introduces harmonics.
- b. **Current density:** Higher current density reduces the volume of copper but increases the losses and temperature.
  - c. **Temperature:** poses a limitation on account of possible damage to insulation and other materials.
  - d. **Insulation** (which is both mechanically and electrically weak): poses a limitation on account of breakdown by excessive voltage gradient, mechanical forces or heat.
  - e. Mechanical strength of the materials poses a limitation particularly in case of large and high speed machines.
  - f. High efficiency and high power factor poses a limitation on account of higher capital cost. (A low value of efficiency and power factor on the other hand results in a high maintenance cost).
  - g. Mechanical Commutation in dc motors or generators leads to poor commutation.

Apart from the above factors Consumer, manufacturer or standard specifications may pose a limitation.

### Materials for Electrical Machines

The main material characteristics of relevance to electrical machines are those associated with conductors for electric circuit, the insulation system necessary to isolate the circuits, and with the specialized steels and permanent magnets used for the magnetic circuit.

#### Conducting materials

Commonly used conducting materials are copper and aluminum. Some of the desirable properties a good conductor should possess are listed below.

1. Low value of resistivity or high conductivity
2. Low value of temperature coefficient of resistance
3. High tensile strength
4. High melting point
5. High resistance to corrosion
6. Allow brazing, soldering or welding so that the joints are reliable
7. Highly malleable and ductile
8. Durable and cheap by cost

Some of the properties of copper and aluminum are shown in the table-2.



Table-2

Sl. No	Particulars	Copper	Aluminum
1	Resistivity at 20 <sup>0</sup> C	0.0172 ohm / m/ mm <sup>2</sup>	0.0269 ohm / m/ mm <sup>2</sup>
2	Conductivity at 20 <sup>0</sup> C	58.14 x 10 <sup>6</sup> S/m	37.2 x 10 <sup>6</sup> S/m
3	Density at 20 <sup>0</sup> C	8933kg/m <sup>3</sup>	2689.9m <sup>3</sup>
4	Temperature coefficient (0-100 <sup>0</sup> C)	0.393 % per <sup>0</sup> C	0.4 % per <sup>0</sup> C
		Explanation: If the temperature increases by 1 <sup>0</sup> C, the resistance increases by 0.4% in case of aluminum	
5	Coefficient of linear expansion (0-100 <sup>0</sup> C)	16.8x10 <sup>-6</sup> per <sup>0</sup> C	23.5 x10 <sup>-6</sup> per <sup>0</sup> C
6	Tensile strength	25 to 40 kg / mm <sup>2</sup>	10 to 18 kg / mm <sup>2</sup>
7	Mechanical property	highly malleable and ductile	not highly malleable and ductile
8	Melting point	1083 <sup>0</sup> C	660 <sup>0</sup> C
9	Thermal conductivity (0-100 <sup>0</sup> C)	599 W/m <sup>0</sup> C	238 W/m <sup>0</sup> C
10	Jointing	can be easily soldered	cannot be soldered easily

For the same resistance and length, cross-sectional area of aluminum is 61% larger than that of the copper conductor and almost 50% lighter than copper.

Though the aluminum reduces the cost of small capacity transformers, it increases the size and cost of large capacity transformers. Aluminum is being much used now a days only because copper is expensive and not easily available. Aluminum is almost 50% cheaper than Copper and not much superior to copper.

### Magnetic materials

The magnetic properties of a magnetic material depend on the orientation of the crystals of the material and decide the size of the machine or equipment for a given rating, excitation required, efficiency of operation etc.

The some of the properties that a good magnetic material should possess are listed below.

1. Low reluctance or should be highly permeable or should have a high value of relative permeability  $\mu_r$ .
2. High saturation induction (to minimize weight and volume of iron parts)
3. High electrical resistivity so that the eddy emf and the hence eddy current loss is less
4. Narrow hysteresis loop or low Coercivity so that hysteresis loss is less and efficiency of operation is high
5. A high curie point. (Above Curie point or temperature the material loses the magnetic property or becomes paramagnetic, that is effectively non-magnetic)
6. Should have a high value of energy product (expressed in joules / m<sup>3</sup>).

Magnetic materials can broadly be classified as Diamagnetic, Paramagnetic, Ferromagnetic, Antiferromagnetic and Ferrimagnetic materials. Only ferromagnetic materials have properties that are well suitable for electrical machines. Ferromagnetic properties are confined almost entirely to iron, nickel and cobalt and their alloys. The only exceptions are some alloys of manganese and some of the rare earth elements.

The relative permeability  $\mu_r$  of ferromagnetic material is far greater than 1.0. When ferromagnetic materials are subjected to the magnetic field, the dipoles align themselves in the direction of the applied field and get strongly magnetized.

Further the Ferromagnetic materials can be classified as Hard or Permanent Magnetic materials and Soft Magnetic materials.

**a) Hard or permanent magnetic materials** have large size hysteresis loop (obviously hysteresis loss is more) and gradually rising magnetization curve.

Ex: carbon steel, tungsten steel, cobalt steel, alnico, hard ferrite etc.

**b) Soft magnetic materials** have small size hysteresis loop and a steep magnetization curve.

Ex: i) cast iron, cast steel, rolled steel, forged steel etc., (in the solid form).

-Generally used for yokes poles of dc machines, rotors of turbo alternator etc., where steady or dc flux is involved.

ii) Silicon steel (Iron + 0.3 to 4.5% silicon) in the laminated form. Addition of silicon in proper percentage eliminates ageing & reduce core loss. Low silicon content steel or dynamo grade steel is used in rotating electrical machines and are operated at high flux density. High content silicon steel (4 to 5% silicon) or transformer grade steel (or high resistance steel) is used in transformers. Further sheet steel may be hot or cold rolled. Cold rolled grain oriented steel (CRGOS) is costlier and superior to hot rolled. CRGO steel is generally used in transformers.

**c) Special purpose Alloys:**

Nickel iron alloys have high permeability and addition of molybdenum or chromium leads to improved magnetic material. Nickel with iron in different proportion leads to

- (i) High nickel permalloy (iron +molybdenum +copper or chromium), used in current transformers, magnetic amplifiers etc.,
- (ii) Low nickel Permalloy (iron +silicon +chromium or manganese), used in transformers, induction coils, chokes etc.
- (iii) Perminvor (iron +nickel +cobalt)
- (iv) Pemendur (iron +cobalt +vanadium), used for microphones, oscilloscopes, etc.
- (v) Mumetal (Copper + iron)

**d) Amorphous alloys (often called metallic glasses):**

Amorphous alloys are produced by rapid solidification of the alloy at cooling rates of about a million degrees centigrade per second. The alloys solidify with a glass-like atomic structure which is non-crystalline frozen liquid. The rapid cooling is achieved by causing the molten

alloy to flow through an orifice onto a rapidly rotating water cooled drum. This can produce sheets as thin as  $10\mu\text{m}$  and a metre or more wide.

These alloys can be classified as iron rich based group and cobalt based group.

Material	Maximum permeability $\mu \times 10^{-3}$	Saturation magnetization in tesla	Coercivity A/m	Curie temperature $^{\circ}\text{C}$	Resistivity $\Omega\text{m} \times 10^8$
3% Si grain oriented	90	2.0	6-7	745	48
2.5% Si grain non-oriented	8	2.0	40	745	44
<0.5% Si grain non oriented	8	2.1	50-100	770	12
Low carbon iron	3-10	2.1	50-120	770	12
78% Ni and iron	250-400	0.8	1.0	350	40
50% Ni and iron	100	1.5-1.6	10	530	60
Iron based Amorphous	35-600	1.3-1.8	1.0-1.6	310-415	120-140

### Insulating materials

To avoid any electrical activity between parts at different potentials, insulation is used. An ideal insulating material should possess the following properties.

- 1) Should have high dielectric strength.
- 2) Should with stand high temperature.
- 3) Should have good thermal conductivity
- 4) Should not undergo thermal oxidation
- 5) Should not deteriorate due to higher temperature and repeated heat cycle
- 6) Should have high value of resistivity ( like  $10^{18} \Omega\text{cm}$ )
- 7) Should not consume any power or should have a low dielectric loss angle  $\delta$
- 8) Should withstand stresses due to centrifugal forces ( as in rotating machines), electro dynamic or mechanical forces ( as in transformers)
- 9) Should withstand vibration, abrasion, bending
- 10) Should not absorb moisture
- 11) Should be flexible and cheap
- 12) Liquid insulators should not evaporate or volatilize

Insulating materials can be classified as Solid, Liquid and Gas, and vacuum. The term insulating material is sometimes used in a broader sense to designate also insulating liquids, gas and vacuum.

Solid: Used with field, armature, transformer windings etc. The examples are:

- 1) Fibrous or inorganic animal or plant origin, natural or synthetic  
paper, wood, card board, cotton, jute, silk etc.,  
rayon, nylon, terelane, asbestos, fiber glass etc.,

- 2) Plastic or resins. Natural resins-lac, amber, shellac etc.,  
Synthetic resins-phenol formaldehyde, melamine, polyesters, epoxy, silicon resins, bakelite, Teflon, PVC etc
- 3) Rubber : natural rubber, synthetic rubber-butadiene, silicone rubber, hypalon, etc.,
- 4) Mineral : mica, marble, slate, talc chloride etc.,
- 5) Ceramic : porcelain, steatite, alumina etc.,
- 6) Glass : soda lime glass, silica glass, lead glass, borosilicate glass
- 7) Non-resinous : mineral waxes, asphalt, bitumen, chlorinated naphthalene, enamel etc.,

Liquid: Used in transformers, circuit breakers, reactors, rheostats, cables, capacitors etc., & for impregnation. The examples are:

- 1) Mineral oil (petroleum by product)
- 2) Synthetic oil askarels, pyranols etc.,
- 3) Varnish, French polish, lacquer epoxy resin etc.,

Gaseous: The examples are:

- 1) Air used in switches, air condensers, transmission and distribution lines etc.,
- 2) Nitrogen use in capacitors, HV gas pressure cables etc.,
- 3) Hydrogen though not used as a dielectric, generally used as a coolant
- 4) Inert gases neon, argon, mercury and sodium vapors generally used for neon sign lamps.
- 5) Halogens like fluorine, used under high pressure in cables

No insulating material in practice satisfies all the desirable properties. Therefore a material which satisfies most of the desirable properties must be selected.

### Classification of insulating materials based on thermal consideration

The insulation system (also called insulation class) for wires used in generators, motors transformers and other wire-wound electrical components is divided into different classes according to the temperature that they can safely withstand.

As per Indian Standard ( Thermal evaluation and classification of Electrical Insulation, IS.No.1271,1985,first revision) and other international standard insulation is classified by letter grades A,E,B,F,H (previous Y,A,E,B,F,H,C).

Insulation class		Maximum operating temperature in °C	Typical materials
Previous	Present		
Y		90	Cotton, silk, paper, wood, cellulose, fiber etc., without impregnation or oil immersed
A	A	105	The material of class Y impregnated with natural resins, cellulose esters, insulating oils etc., and also laminated wood, varnished paper etc.
E	E	120	Synthetic resin enamels of vinyl acetate or nylon tapes, cotton and paper laminates with formaldehyde bonding etc.,
B	B	130	Mica, glass fiber, asbestos etc., with suitable bonding substances, built up mica, glass fiber and asbestos laminates.

F	F	155	The materials of Class B with more thermal resistance bonding materials
H	H	180	Glass fiber and asbestos materials and built up mica with appropriate silicone resins
C	C	>180	Mica, ceramics, glass, quartz and asbestos with binders or resins of super thermal stability.

The maximum operating temperature is the temperature the insulation can reach during operation and is the sum of standardized ambient temperature i.e. 40 degree centigrade, permissible temperature rise and allowance tolerance for hot spot in winding. For example, the maximum temperature of class B insulation is (ambient temperature 40 + allowable temperature rise 80 + hot spot tolerance 10) = 130°C.

Insulation is the weakest element against heat and is a critical factor in deciding the life of electrical equipment. The maximum operating temperatures prescribed for different class of insulation are for a healthy lifetime of 20,000 hours. The height temperature permitted for the machine parts is usually about 200°C at the maximum. Exceeding the maximum operating temperature will affect the life of the insulation. As a rule of thumb, the lifetime of the winding insulation will be reduced by half for every 10 °C rise in temperature. The present day trend is to design the machine using class F insulation for class B temperature rise.

**UNIT-2**

**DESIGN OF DC MACHINES:** Output equation, choice of specific loadings and choice of number of poles, design of Main dimensions of the DC machines, Design of armature slot dimensions, commutator and brushes, magnetic circuit -estimation of ampere turns, design of yoke and poles-main and inter poles, field windings – shunt, series and inter poles. 10 Hours

**Chapter.2 DESIGN OF DC MACHINES****Details to be specified while ordering a DC machine or consumer's specification**

1. Output : kW (for generators), kW or Hp (for motors)
2. Voltage : V volt
3. Speed : N rpm
4. Rating : Continuous or Short time
5. Temperature rise:  $\theta^{\circ}\text{C}$  for an ambient temperature of  $40^{\circ}\text{C}$
6. Cooling : Natural or forced cooling
7. Type: Generator or motor, separately excited or self-excited-shunt, series, or compound, if compound type of connection – long or short shunt, type of compounding – cumulative or differential, degree of compounding – over, under or level. With or without inter poles, with or without compensating windings, with or without equalizer rings in case of lap winding.
8. Voltage regulation ( in case of generators) : Range and method
9. Speed control ( in case of motors ) : range and method of control
10. Efficiency: must be as for as possible high (As the efficiency increases, cost of the machine also increases).
11. Type of enclosure: based on the field of application – totally enclosed, screen protected, drip proof, flame proof, etc.,
12. Size of the machine etc.,

**Size of the DC machine**

The size of the DC machine depends on the main or leading dimensions of the machine viz., diameter of the armature D and armature core length L. As the output increases, the main dimensions of the machine D and L also increases.

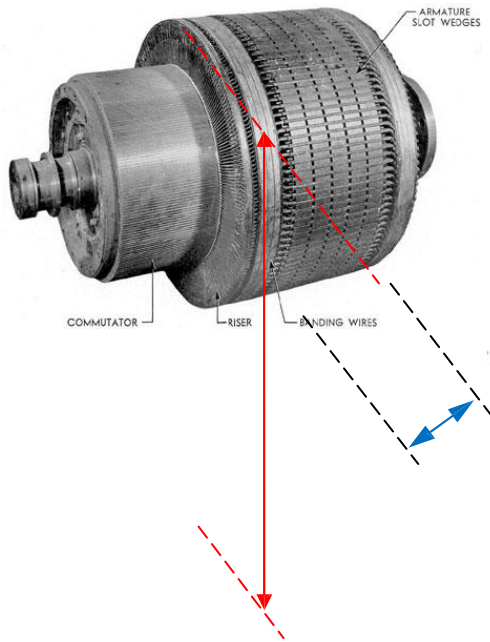

Figure.1. Armature of a dc machine

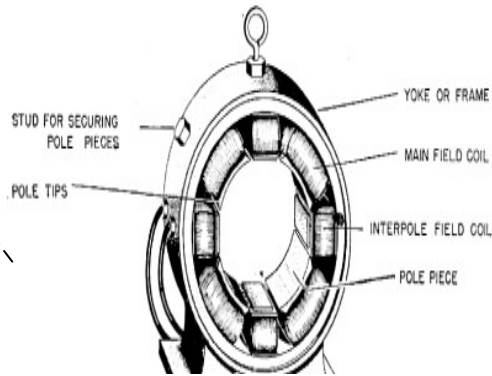
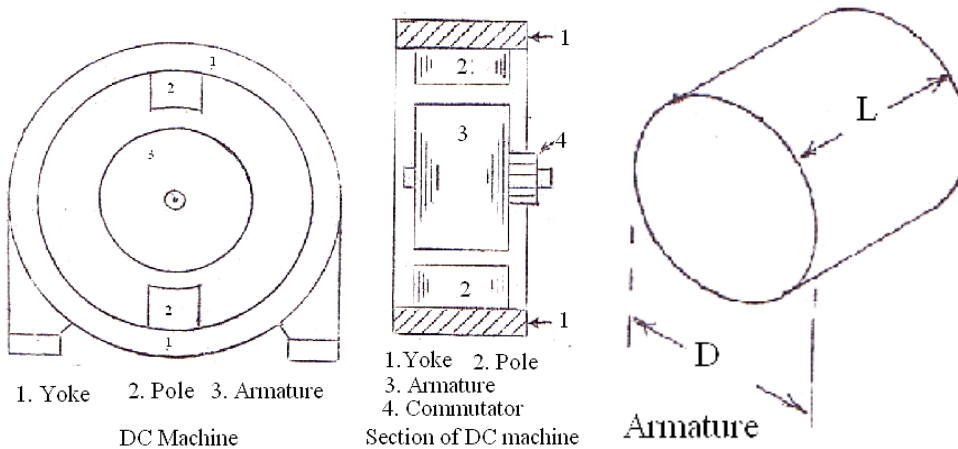

Figure.2. Yoke and pole arrangement of a dc machine



**OUTPUT EQUATION**

**Note:** Output equation relates the output and main dimensions of the machine. Actually it relates the power developed in the armature and main dimensions.

	E : emf induced or back emf
	$I_a$ : armature current
	$\phi$ : Average value of flux / pole
	Z : Total number of armature conductors
	N : Speed in rpm
<b>Derivation:</b>	P : Number of poles
Nomenclature:	A : number of armature paths or circuits
	D : Diameter of the armature
	L : Length of the armature core

Power developed in the armature in kW =  $E I_a \times 10^{-3}$

$$\begin{aligned}
 &= \frac{\phi Z N P}{60 A} \times I_a \times 10^{-3} \\
 &= (P\phi) \times \frac{I_a Z}{A} \times \frac{N \times 10^{-3}}{60} \dots\dots (1)
 \end{aligned}$$

The term  $P\phi$  represents the total flux and is called the magnetic loading. Magnetic loading/unit area of the armature surface is called the specific magnetic loading or average value of the flux density in the air gap  $B_{av}$ . That is,



$$B_{av} = \frac{P\phi}{\pi DL} \text{ Wb/m}^2 \text{ or tesla denoted by } T$$

$$\text{Therefore } P\phi = B_{av} \pi DL \dots\dots\dots (2)$$

The term  $(I_a Z/A)$  represents the total ampere-conductors on the armature and is called the electric loading. Electric loading/unit length of armature periphery is called the specific electric loading  $q$ . That is,

$$q = \frac{I_a Z}{A \pi D} \text{ ampere - conductors / m}$$

$$\text{Therefore } I_a Z/A = q \pi D \dots\dots\dots (3)$$

Substitution of equations 2 and 3 in 1, leads to

$$\begin{aligned} kW &= B_{av} \pi DL \times q \pi D \times \frac{N \times 10^{-3}}{60} \\ &= 1.64 \times 10^{-4} B_{av} q D^2 L N \\ &= C_0 D^2 L N \end{aligned}$$

where  $C_0$  is called the output coefficient of the DC machine and is equal to  $1.64 \times 10^{-4} B_{av} q$ .

$$\text{Therefore } D^2 L = \frac{kW}{1.64 \times 10^{-4} B_{av} q N} \text{ m}^3$$

The above equation is called the output equation. The  $D^2 L$  product represents the size of the machine or volume of iron used. In order that the maximum output is obtained/kg of iron used,  $D^2 L$  product must be as less as possible. For this, the values of  $q$  and  $B_{av}$  must be high.

### Effect of higher value of $q$

Note: Since armature current  $I_a$  and number of parallel paths  $A$  are constants and armature diameter  $D$  must be as less as possible or  $D$  must be a fixed minimum value, the number of armature conductors increases as  $q = I_a Z / A \pi D$  increases.

- As  $q$  increases, number of conductors increases, resistance increases,  $I^2 R$  loss increases and therefore the temperature of the machine increases. Temperature is a limiting factor of any equipment or machine.
- As  $q$  increases, number of conductors increases, conductors/slot increases, quantity of insulation in the slot increases, heat dissipation reduces, temperature increases, losses increases and efficiency of the machine reduces.
- As  $q$  increases, number of conductors increases, armature ampere-turns per pole  $AT_a / \text{pole} = (I_a Z / 2 A P)$  increases, flux produced by the armature increases, and therefore the effect of armature reaction increases. In order to overcome the effect of

armature reaction, field mmf has to be increased. This calls for additional copper and increases the cost and size of the machine.

- d. As  $q$  increases, number of conductors and turns increases, reactance voltage proportional to  $(\text{turns})^2$  increases. This leads to sparking commutation.

### Effect of higher value of $B_{av}$

- a. As  $B_{av}$  increases, core loss increases, efficiency reduces.  
 b. As  $B_{av}$  increases, degree of saturation increases, mmf required for the magnetic circuit increases. This calls for additional copper and increases the cost of the machine.

It is clear that there is no advantage gained by selecting higher values of  $q$  and  $B_{av}$ . If the values selected are less, then  $D^2L$  will be large or the size of the machine will unnecessarily be high. Hence optimum value of  $q$  and  $B_{av}$  must be selected.

In general  $q$  lies between 15000 and 50000 ampere-conductors/m.

Lesser values are used in low capacity, low speed and high voltage machines.

In general  $B_{av}$  lies between 0.45 and 0.75 T.

### SEPARATION OF $D^2L$ PRODUCT

Knowing the values of kW and N and assuming the values of  $q$  and  $B_{av}$ , a value for

$$D^2L = \frac{kW}{1.64 \times 10^{-4} \times B_{av} q N} \text{ can be calculated.}$$

Let it be  $0.1 \text{ m}^3$ .

Since the above expression has two unknowns namely D and L, another expression relating D and L must be known to find out the values of D and L.

Usually a value for the ratio armature core length L to pole pitch is assumed to separate  $D^2L$  product. The pole pitch  $\tau$  refers to the circumferential distance corresponding one pole at diameter D. In practice  $L/\tau$  lies between 0.55 and 1.1.

$$\begin{aligned} \text{Therefore } L &= (0.55 \text{ to } 1.1) \tau \\ &= (0.55 \text{ to } 1.1) \pi D / P \end{aligned}$$

$$\text{If } L/\tau = 1.0 \text{ and } P = 4, \text{ then } L = 1.0 \times \pi D / P = 1.0 \times \pi D / 4 = 0.785D.$$

$$\text{Therefore } D^2 \times 0.785 D = 0.1 \text{ or } D = 0.5\text{m. Thus } L = 0.785 \times 0.5 = 0.395 \text{ m.}$$

Note: The  $D^2L$  product can also be separated by assuming a value for the peripheral velocity of the armature.

### LIMITATIONS OF $D$ AND $L$

As the diameter of the armature increases, the peripheral velocity of the armature  $v = \pi DN / 60$  m/s, centrifugal force and its effects increases. Therefore the machine must be mechanically made robust to withstand the effect of centrifugal force. This increases the cost of the machine. In general for normal construction, peripheral velocity should not be greater than 30 m/s as far as possible.

To prevent arcing between commutator segments, voltage between the commutator segments should not be greater than about 20V on open circuit. If a single turn coil is used then the voltage/conductor  $e = B_{av} L v$  should not be more than 10V.

( $B_{av}$  – Average value of flux density in the air gap in tesla,  $L$  – Length of the conductor or gross armature core length in metre and  $v$  – Peripheral velocity of armature in m/s).

Therefore, armature core length  $L = \frac{e}{B_{av} v}$  should not be greater than  $10 / (0.75 \times 30) = 0.44\text{m}$  for normal design.

### Ventilating ducts and net iron length of armature core

To keep down the temperature rise of the machine parts, the core is provided with both radial and axial ventilating ducts. Radial ducts are created by providing vent or duct spacers in between core packets of width 5-7 cm. Width of the radial duct lies between 0.8 and 1.0 cm in practice.

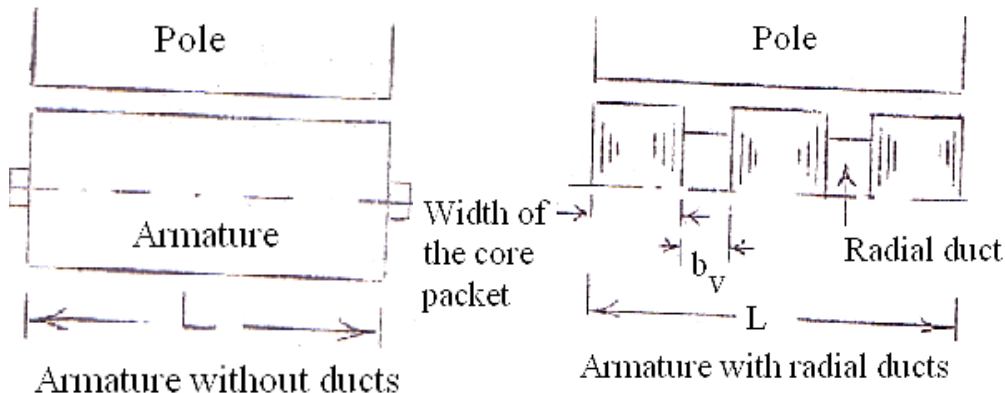

It is clear from the figure that the net core length =  $(L - n_v b_v)$

where  $n_v$  – number of ventilating ducts and  $b_v$  – width of the ventilating duct.

Since the core is laminated to reduce the eddy current loss and flux takes the least reluctance path, flux confines to the iron only. Therefore the length over which the flux passes is not  $L$  or  $(L - n_v b_v)$  but less than that. Generally the thickness of insulation on the laminated core will be

around 10% of the gross core length. Therefore the net iron length will be 0.9 times the net core length or net iron length,

$$L_i = K_i (L - n_v b_v)$$

where  $K_i$  is called the iron or stacking factor and is approximately 0.9 in practice.

### Estimation of number of ventilating ducts

Determine the number of ducts if the length of armature core is 35 cm.

Since the width of the core packet lies between 5 and 7 cm, let the width of the core packet be 6 cm. Therefore number of core packets is equal to  $35 / 6$  or 6 say. Six core packets lead to 5 ducts. If the width of the duct is assumed to be 1.0 cm, then the net core length will be  $(35 - 1 \times 5) = 30$  cm and each core packet after revision will be  $30 / 6 = 5$  cm in width.

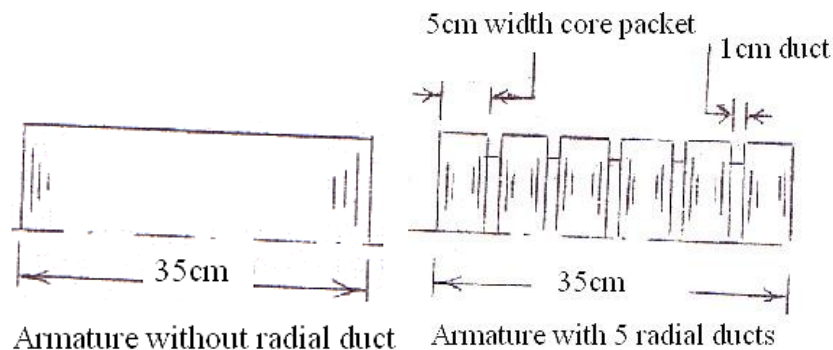

### CHOICE OF NUMBER OF POLES

In order to decide what number of poles (more or less) is to be used, let the different factors affecting the choice of number of poles be discussed based on the use of more number of poles.

#### 1. Frequency

As the number of poles increases, frequency of the induced emf  $f = \frac{PN}{120}$  increases, core loss in the armature increases and therefore efficiency of the machine decreases.

#### 2. Weight of the iron used for the yoke

Since the flux carried by the yoke is approximately  $\phi / 2$  and the total flux  $\phi_T = p\phi$  is a constant for a given machine, flux density in the yoke

$$B_y = \frac{\phi / 2}{\text{cross sectional area of the yoke } A_y} = \frac{\phi_T}{2 P A_y} \propto \frac{1}{P A_y}.$$

It is clear that  $A_y$  is  $\propto 1/P$

as  $B_y$  is also almost constant for a given iron. Thus, as the number of poles increases,  $A_y$  and hence the weight of iron used for the yoke reduces.

### 3. Weight of iron used for the armature core (from the core loss point of view)

Since the flux carried by the armature core is  $\phi/2$ , eddy current loss in the armature core

$$\propto B_c^2 f^2$$

$$\propto \left[ \frac{\phi/2}{A_c} \right]^2 f^2 \propto \left[ \frac{\phi_T}{2 P A_c} \right]^2 \times \left[ \frac{P N}{120} \right]^2$$

$$\propto \frac{1}{A_c^2} \text{ is independent of the number of poles.}$$

On the other hand, since the hysteresis loss in the armature core is

$$\propto B_c^{1.6} f \propto \left( \frac{\phi_T}{2 P A_c} \right)^{1.6} \times \frac{P N}{120} \propto \frac{1}{P^{0.6} A_c^{1.6}}, \text{ the armature core area } A_c$$

$\propto \frac{1}{P^{0.6/1.6}}$  decreases as the number of poles increases for a given hysteresis loss. Thus the weight of iron used for the armature core reduces as the number of poles increases.

### 4. Weight of overhang copper

For a given active length of the coil, overhang  $\propto$  pole pitch  $\pi D/P$  goes on reducing as the number of poles increases. As the overhang length reduces, the weight of the inactive copper used at the overhang also reduces.

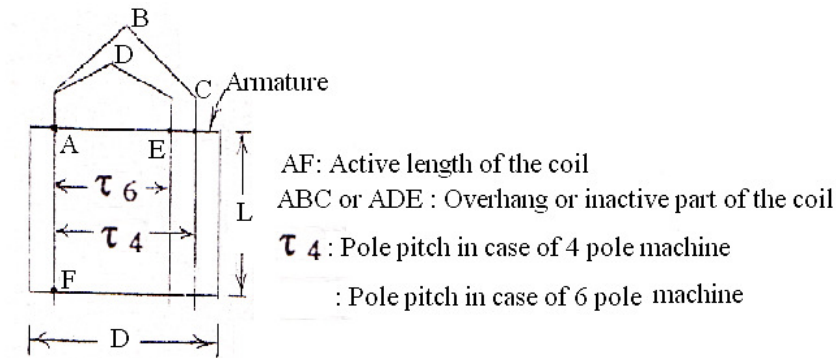

### 5. Armature reaction

Since the flux produced by the armature  $\phi_a = \frac{AT_a / \text{pole}}{\text{reluctance}}$  and armature ampere turns  $AT_a$

$/ \text{pole} = \frac{I_a Z}{2 A P}$  is proportional to  $1/P$ ,  $\phi_a$  reduces as the number of poles increases. This in turn reduces the effect of armature reaction.

## 6. Overall diameter

When the number of poles is less,  $AT_a / \text{pole}$  and hence the flux, produced by the armature is more. This reduces the useful flux in the air gap. In order to maintain a constant value of air gap flux, flux produced by the field or the field ampere-turns must be increased. This calls for more field coil turns and size of the coil defined by the depth of the coil  $d_f$  and height of the coil  $h_f$  increases. In order that the temperature rise of the coil is not more, depth of the field coil is generally restricted. Therefore height of the field coil increases as the size of the field coil or the number of turns of the coil increases. As the pole height, is proportional to the field coil height, height of the pole and hence the overall diameter of the machine increases with the increase in height of the field coil.

Obviously as the number of poles increases, height of the pole and hence the overall diameter of the machine decreases.

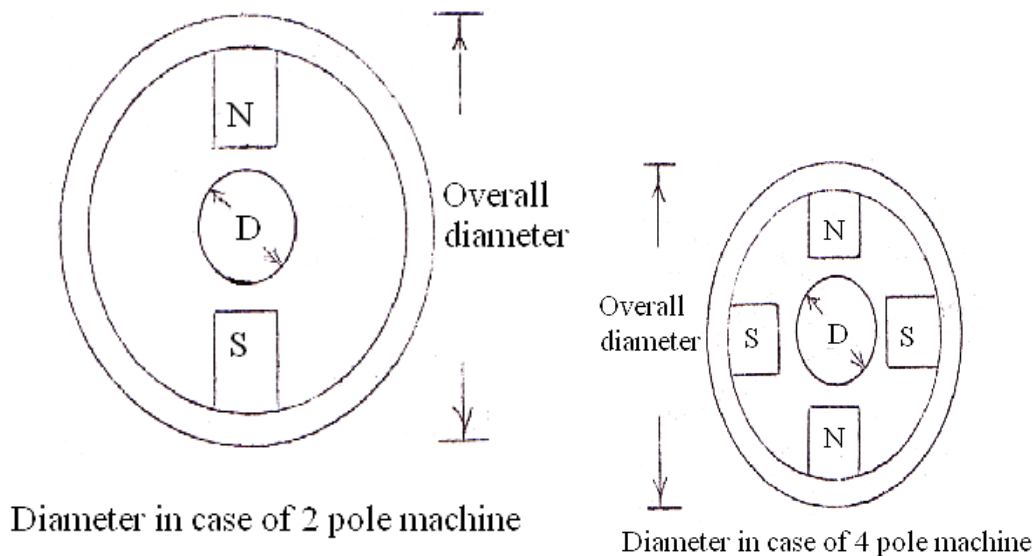

## 7. Length of the commutator

Since each brush arm collects the current from every two parallel paths, current / brush arm  $= 2 I_a / A$  and the cross sectional area of the brush / arm

$$A_b = 2I_a / A \delta_b = 2I_a / P \delta_b$$

$$\propto 1 / P$$

reduces as the number of poles increases.

As  $A_b = t_b w_b n_b$  and  $t_b$  is generally held constant from the commutation point of view,  $w_b n_b$  reduces as  $A_b$  reduces. Hence the length of the commutator

$L_c = (w_b n_b + \text{clearances})$  reduces as  $A_b$  reduces or the number of poles increases.

$w_b$  – width of the brush,  $t_b$  – thickness of the brush,  $n_b$  – number of brushes per spindle

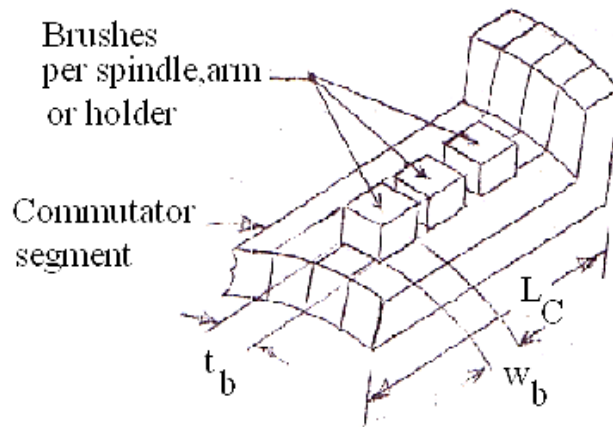

A portion of the commutator

### 8. Flash over

As the number of poles increases, voltage between the segments

$E_b = \frac{\text{voltage between positive and negative brushes}}{\text{number of segments / pole}}$  increases. Because of the increased

value of  $E_b$  and carbon dust collected in the space where the mica is undercut, chances of arcing between commutator segments increases. The arc between the segments in turn may bridge the positive and negative brushes leading to a dead short circuit of the armature or flash over.

### 9. Labour charges

As the number of poles increases cost of labour increases as more number of poles are to be assembled, more field coils are to be wound, placed on to the pole, insulate, interconnect etc.

It is clear that, when the number of poles is more, weight of iron used for yoke and armature core, weight of inactive copper, overall diameter, length of commutator and effect of armature reaction reduces. On the other hand efficiency reduces chances of flash over increases and cost of machine increases.

Since the advantages outnumber the disadvantages, more number of poles is preferable.

Thus, though more number of poles is preferable, it is not advisable from the cost point of view. In general the number of poles should be so selected that good operating characteristics are obtained with minimum weight of active material and minimum cost of construction.

**SELECTION OF NUMBER OF POLES (For a preliminary design)**

As the armature current increases, cross sectional area of the conductor and hence the eddy current loss in the conductor increases. In order to reduce the eddy current loss in the conductor, cross-sectional area of the conductor must be made less or the current / path must be restricted.

For a normal design, current / parallel path should not be more than about 200A. However, often, under enhanced cooling conditions, a current / path of more than 200A is also being used. By selecting a suitable number of paths for the machine, current / path can be restricted and the number of poles for the machine can be decided.

While selecting the number of poles, the following conditions must also be considered as far as possible.

- a. Frequency of the armature induced emf  $f = PN/120$  should be as far as possible between 25 and 50 Hz.
- b. Armature ampere turns / pole  $= I_a Z / 2AP$  should not be greater than 10000.

Example: Select a suitable number of poles for a 1000kW, 500V DC machine.

$$\text{Armature current (approximately) } I_a = \frac{1000 \times 10^3}{500} = 2000\text{A}$$

In order that the current / path is not more than about 200A, lap winding has to be used having number of parallel paths  $= \frac{2000}{200} = 10$ . Since the number of parallel paths is equal to number of poles in a simplex lap winding, 10 poles can be selected for the machine as a preliminary value. (The number of poles selected can also be like 8 or 12).

Example: Select a suitable number of poles for a 100kW, 500V DC machine.

$$\text{Armature current (approximately) } I_a = \frac{1000 \times 10^3}{500} = 200\text{A} .$$



For a current of 200A a lap or wave winding can be used. Since the minimum number of paths and poles is two, 2 poles are sufficient for the machine. However to gain more advantages of more number of poles, let the number of poles be 4.

### ARMATURE WINDING

The armature winding can broadly be classified as concentrated and distributed winding.

In case of a concentrated winding, all the conductors / pole is housed in one slot. Since the conductors / slot is more, quantity of insulation in the slot is more, heat dissipation is less, temperature rise is more and the efficiency of operation will be less. Also emf induced in the armature conductors will not be sinusoidal. Therefore

- design calculations become complicated (because of the complicated expression of non-sinusoidal wave).
- Core loss increases (because of the fundamental and harmonic components of the non-sinusoidal wave) and efficiency reduces.
- Communication interference may occur (because of the higher frequency components of the non-sinusoidal wave).

Hence no concentrated winding is used in practice for a DC machine armature.

In a distributed winding (used to overcome the disadvantages of the concentrated winding), conductors / pole is distributed in more number of slots. The distributed winding can be classified as single layer winding and double layer winding.

In a single layer winding, there will be only one coil side in the slot having any number of conductors, odd or even integer depending on the number of turns of the coil. In a double layer winding, there will be 2 or multiple of 2 coil sides in the slot arranged in two layers. Obviously conductors / slot in a double layer winding must be an even integer.

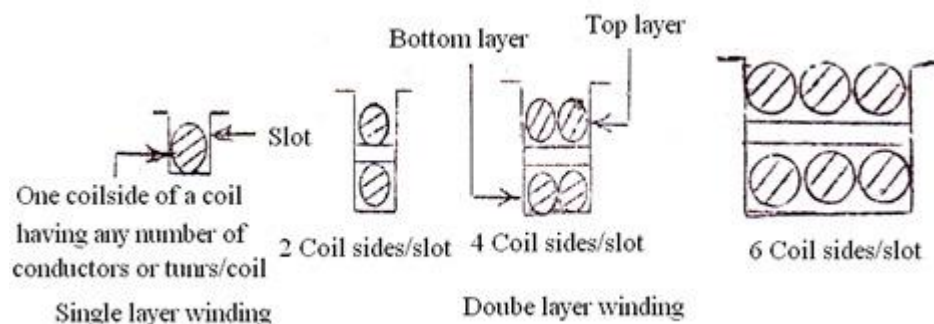

Since for a given number of conductors, poles and slots, a single layer winding calls for less number of coils of more number of turns, reactance voltage proportional to  $(\text{turn})^2$  is high. This decreases the quality of commutation or leads to sparking commutation. Hence a single layer winding is not generally used in DC machines. However it is much used in alternators and induction motors where there is no commutation involved.

Since a double layer winding calls for more number of coils of less number of turns/coil, reactance voltage proportional to (turn)<sup>2</sup> is less and the quality of commutation is good. Hence double layer windings are much used in DC machines.

Unless otherwise specified all DC machines are assumed to be having a double layer winding. A double layer winding can further be classified as simplex or multiplex and lap or wave winding.

### CHOICE BETWEEN A LAP AND WAVE WINDING

Since emf induced or back emf  $E = \frac{\phi Z N P}{60A}$ , number of armature conductors  $Z$

$= \frac{60EA}{\phi NP} = KA$  for given value of  $E$ ,  $N$  and  $P\phi$ .  $K$  is a constant. Therefore  $Z_{lap} = KP$ ,  $Z_{wave} =$

$K2$  and  $Z_{lap} = \frac{P}{2} Z_{wave}$ . It is clear that the number of conductors, coils and commutator

segments in a lap winding is more than that of a wave winding for the same number of turns/coil in both cases. Also since a lap winding is generally equipped with equalizer rings, cost of a lap winding is more than that of a wave winding.

Since a lap winding provides more number of parallel paths, it is generally used for low voltage and high current machines (Ex: machines used for electroplating, battery charging etc). A wave winding is generally used for high voltage and low current machines.

Note:

a. A lap winding can be used for any capacity machine. But a wave winding is to be used only for low capacity machines. As the cost of the wave winding is less, almost all low capacity machines employ wave winding.

b. While selecting the type of winding the following conditions must also be considered as far as possible.

i) Commutator segment pitch  $\tau_c = (\pi \times \text{diameter of the commutator } D_c) / \text{number of commutator segments}$  should not be less than 4mm. Otherwise the segments becomes mechanically weak. (The value 4mm is applicable to medium capacity machines and must only be taken as a guiding value and need not be strictly followed).

ii) Voltage between the commutator segments  $E_b$  on open circuit =  $\frac{\text{emf induced} \times P}{\text{number of segments}}$  should not be more than 20V. Otherwise arcing between the segments might result. Obviously voltage / conductor should not be greater than 10V on open circuit.

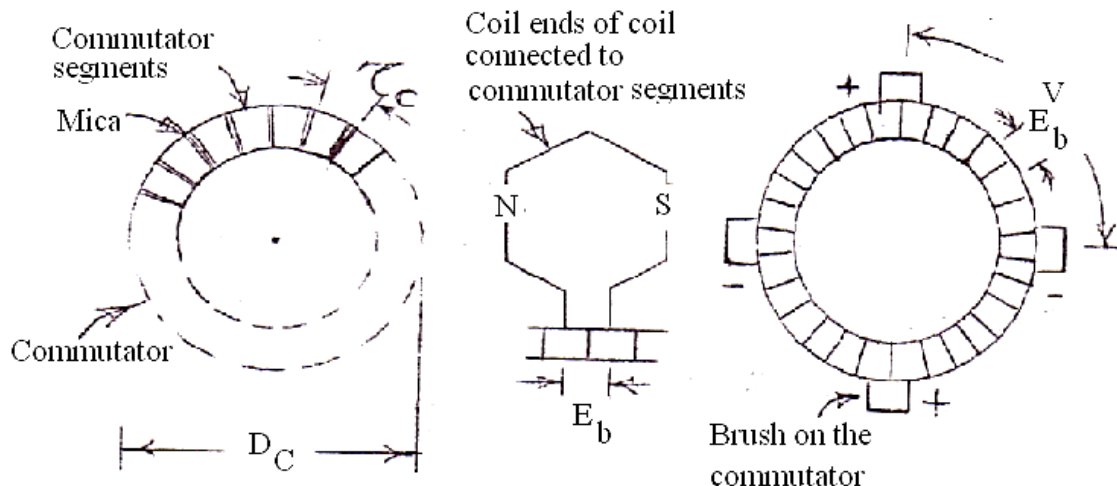

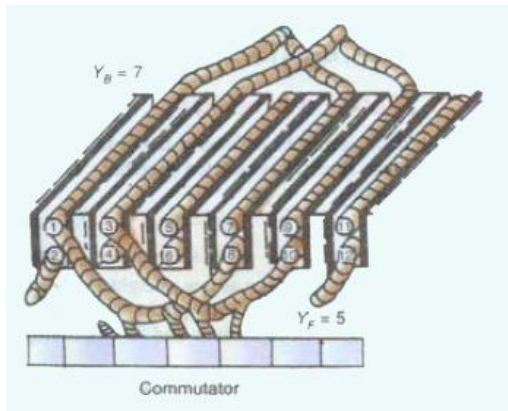

Sketch showing the coil end connection to commutator segments

### NUMBER OF ARMATURE CONDUCTORS

Since the emf induced or back emf  $E = \frac{\phi ZNP}{60A}$ , number of armature conductors

$Z = \frac{60EA}{\phi NP}$  where  $\phi = \frac{B_{av} \pi DL}{P}$  Wb. For a preliminary design emf induced can be taken as the terminal voltage in case of a generator and back emf can be taken as the applied voltage in case of a motor.

The number of armature conductors can also be calculated by considering the specific electric loading. In that case  $Z = \frac{qA \pi D}{I_a}$ . The number of conductors must be an even integer.

### CROSS-SECTIONAL AREA OF THE ARMATURE CONDUCTORS

Since the armature conductors are connected in series in any of the parallel paths of dc machine, maximum value of the current to be carried by the conductor is  $I_a / A$  and the cross sectional area of the conductor  $a = I_a / A\delta$  mm<sup>2</sup>. The current density  $\delta$  lies between 4.5 and 7.0 A / mm<sup>2</sup> in practice.

Note:

As the current density increases, cross sectional area decreases, resistance of the conductor increases,  $I^2R$  loss increases and temperature of the machine increases. If the cooling facility is not good, temperature rise will unnecessarily be high. Hence higher value of current density should be used in machines where the peripheral velocity or speed of operation is high or where cooling facility is good.

For the calculated area 'a', a round, square or rectangular section conductor can be used. (Trapezoidal section conductor is also used but only in case of squirrel cage rotor of an induction motor for increasing the starting torque).

### CHOICE BETWEEN A ROUND AND RECTANGULAR CONDUCTOR

By considering the coil space factor, what type of conductor section is preferable can be decided.

Coil space factor  $S_f$  is defined as the ratio of the area of copper in the coil to the area of the coil. That is,

$$S_f = \frac{\text{Area of copper in the coil } a_f T_f}{\text{Overall area of the coil } h_f d_f} < 1.0$$

where

$a_f$  – cross sectional area of copper or conductor

$T_f$  – number of copper sections (or turns) in the coil

$d_f$  – depth of the coil and  $h_f$  – height of the coil.

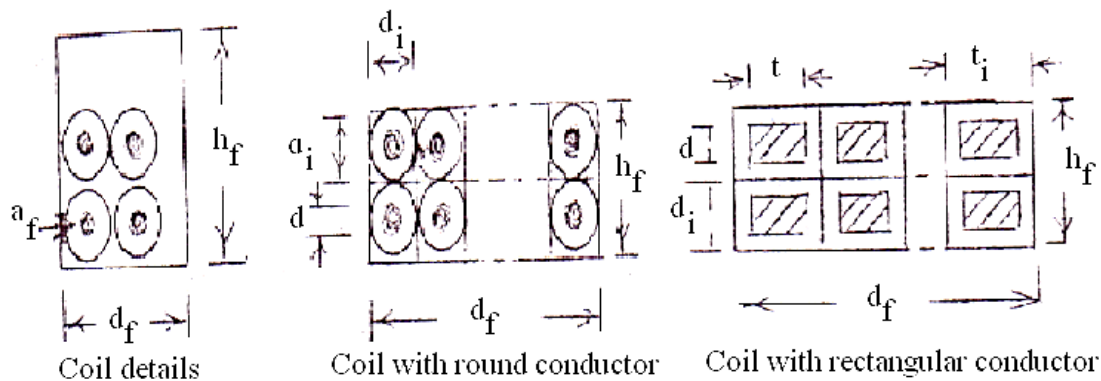

If  $d$  is the diameter of the bare conductor and  $d_i$  is the diameter with insulation, then in case of round conductor

$$S_f = \frac{(\pi d^2/4) \times T_f}{d_i^2 \times T_f} = 0.785(d/d_i)^2$$

and is always less than 0.785. In practice  $S_f$  lies between 0.3 and 0.65 in case of round conductors.

If  $d$  and  $t$  are the depth and width of the rectangular / square conductor without insulation and  $d_i$  and  $t_i$  are the depth and width with insulation, then in case of a rectangular /square conductor

$$S_f = S_f = \frac{dt \times T_f}{d_i t_i \times T_f} = \frac{dt}{d_i t_i} \text{ and lies between 0.7 and 0.85.}$$

[Note:

Since the rectangular conductors can be wound closely without wasting any space in between conductors,  $S_f$  in case of a rectangular conductor is more than that of a round conductor of same cross-sectional area.]

If  $a_f = 100\text{mm}^2$  and  $T_f = 48$ , then area of the coil,

$$h_f d_f = \frac{a_f T_f}{S_f} = \frac{100 \times 48}{0.6} = 8000 \text{ mm}^2, \text{ in case of round conductors with the}$$

assumption that  $S_f = 0.6$ .

$$= \frac{100 \times 48}{0.8} = 6000 \text{ mm}^2, \text{ in case of a rectangular conductors with the}$$

assumption that  $S_f = 0.8$

It is clear that rectangular conductors call for less space as compared to round conductor of same cross sectional area. Though a rectangular conductor is preferable to round conductor, it is costlier than the round conductors. (Quantity of insulation required in case of a rectangular conductor is more than that of the round conductor. Hence the cost is more). Hence rectangular conductors are used when the conductor cross sectional area is more than about  $10 \text{ mm}^2$ .

### DETAILS OF INSULATION

Desirable properties of a good insulator:

1. Should have a high dielectric strength
2. Should withstand a high temperature
3. Should have a high resistivity
4. Should not absorb moisture
5. Should have a low dielectric hysteresis loss
6. Should withstand vibration, abrasion, bending
7. Should be flexible and cheap.

No insulating material in practice satisfies all the desirable properties. Therefore materials which satisfy most of the desirable properties must be selected. Based on the temperature withstanding ability, the insulating materials have been classified as indicated below according to ISI (now BIS) – 1271, 1985, first revision.

Class of insulation	– Y	A	E	B	F	H	C
Maximum temperature $^{\circ}\text{C}$ –	90 $^{\circ}\text{C}$	105 $^{\circ}\text{C}$	120 $^{\circ}\text{C}$	135 $^{\circ}\text{C}$	155 $^{\circ}\text{C}$	180 $^{\circ}\text{C}$	>180

Class Y : Cotton, silk, paper, wood, cellulose, fiber etc., without impregnation or oil immersed.

Class A : The material of class Y impregnated with natural resins, cellulose esters, insulating oils etc., and also laminated wood, varnished paper etc.

Class E : Synthetic resin enamels of vinyl acetate or nylon tapes, cotton and paper laminates with formaldehyde bonding etc.,

Class B : Mica, glass fiber, asbestos etc., with suitable bonding substances, built up mica, glass fiber and asbestos laminates.

Class F : The materials of Class B with more thermal resistance bonding materials.

Class H : Glass fiber and asbestos materials and built up mica with appropriate silicone resins.

Class C : Mica, ceramics, glass, quartz and asbestos with binders or resins of super thermal stability.

### **Insulation on conductors:**

In practice, the most important factor influencing the structure of the insulation is the rated voltage of the machine. Based on the rated voltage, electrical machines can be divided into high voltage and low voltage machines. A low voltage machine is a machine the rated voltage of which is below 1000V.

Insulation on the conductors serves as an inter turn insulation and may be enamel, cotton (single cotton covered SCC or double cotton covered DCC), rayon, silk, glass fiber, asbestos etc.

Addition of insulation to

- a. Round wires or conductors – (0.015 to 0.075) mm for enamel covering  
- (0.2 to 0.35) mm for dcc
- b. Strip or rectangular conductors – (0.06 to 0.15) mm for enamel covering  
- (0.45 to 0.5) mm for dcc

For commercial voltages (up to 1000V) enameled wires are generally used.

For further details chapter.3, Electrical Machine Design Data Book, A.Shanmugasundaram can be referred.

### **TYPES OF SLOTS**

The slots can be open, semi-closed or closed type. Slots may be parallel sided or tapered (varying width). The tooth may also be of parallel sided or tapered. Whenever a double layer winding is used, slots of parallel sided (or of constant slot width) are to be used.

Plain un-notched slots or slots without wedge portion are used only for low capacity machines. In this case the coils are restricted from coming out of the slot by the use of steel binding wires. This type of slots is used only in machines where the peripheral velocity is not more than about 25 m/s. For machines of higher peripheral velocity ear notched slots or slots with lip and wedge portions are used.

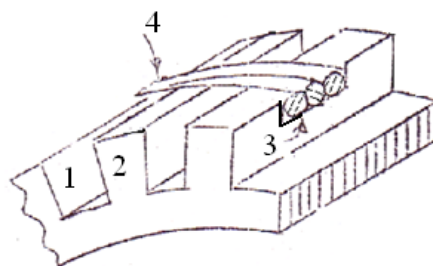
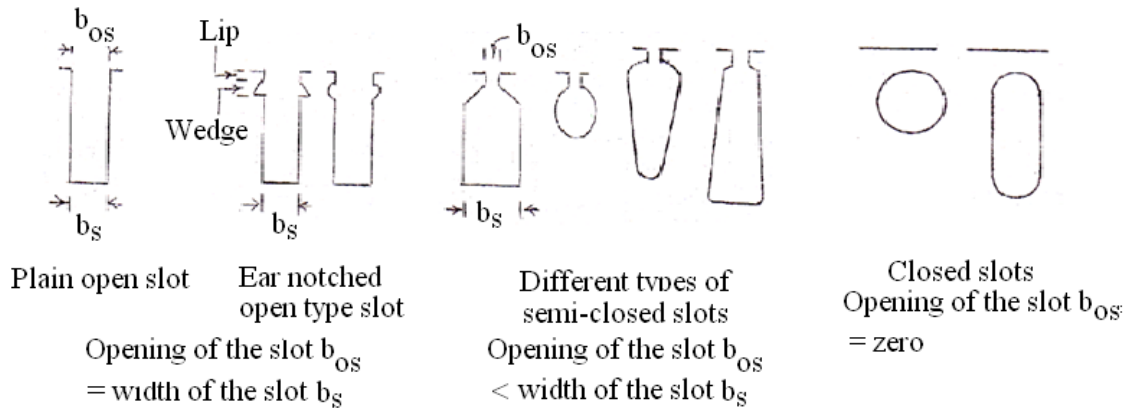

1. Slot
2. Tooth
3. Recess for steel binding wire i.e. 4.

Steel binding wire used to restrict the conductors or coils from coming out of the slots because of centrifugal force when the armature is rotating.



Armature with steel binding wire

Since wide open slots increases the reluctance of the air gap and causes the flux to pulsate in comparison with the closed or semi closed slots, open slots are not preferable. But open slots offers the advantage of placing the coils into the slots and removing them from the slots easily for repair. Also coils can be fully insulated or tapped before being placed into the slots.

With semi closed slots, the coils are to be placed into the slots, turn by turn and therefore it is time consuming and expensive.

With closed slots, preformed coil placement and removal is very difficult and hence no closed slots are used in practice for DC machine armature, stator of alternator or induction motor. However closed slots are used in case of squirrel cage rotor of an induction motor.

In general open type of slots is used in case of high capacity machines and semi closed slots in case of medium and low capacity machines.



## NUMBER OF ARMATURE SLOTS

In order to decide what number of slots (more or less) is to be used, the following merits and demerits are considered.

1. As the number of slots increases, cost of punching the slot increases, number of coils increases and hence the cost of the machine increases.
2. As the number of slots increases, slot pitch

$$\begin{aligned}\lambda_s &= (\text{slot width } b_s + \text{tooth width } b_t) \\ &= \pi D / \text{number of slots } S\end{aligned}$$

decreases and hence the tooth width reduces. This makes the tooth mechanically weak, increases the flux density in the tooth and the core loss in the tooth. Therefore efficiency of the machine decreases.

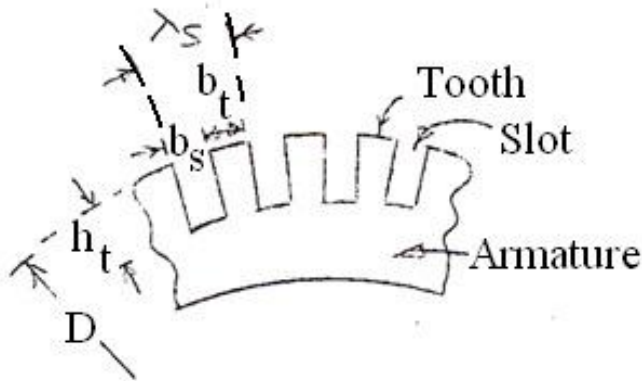

If the slots are less in number, then the cost of punching & number of coils decreases, slot pitch increases, tooth becomes mechanically strong and efficiency increases, quantity of insulation in the slot increases, heat dissipation reduces, temperature increases and hence the efficiency decreases.

It is clear that not much advantage is gained by the use of either too a less or more number of slots.

As a preliminary value, the number of slots can be selected by considering the slot pitch. The slot pitch can assumed to be between (2.5 and 3.5) cm. (This range is applicable to only to medium capacity machines and it can be more or less for other capacity machines).

The selection of the number of slots must also be based on the type of winding used, quality of commutation, flux pulsation etc.

When the number of slot per pole is a whole number, the number slots embraced by each pole will be the same for all positions of armature. However, the number teeth per pole will not be same.

This causes a variation in reluctance of the air gap and the flux in the air gap will pulsate. Pulsations of the flux in the air gap produce iron losses in the pole shoe and give rise to

magnetic noises. On the other hand, when the slots per pole is equal to a whole number plus half the reluctance of the flux path per pole pair remains constant for all positions of the armature, and there will be no pulsations or oscillations of the flux in the air gap.

To avoid pulsations and oscillations of the flux in the air gap, the number of slots per pole should be a whole number plus half. When this is not possible or advisable for other reasons, the number of slots per pole arc should an integer.

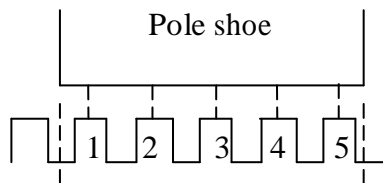

Number of teeth/pole shoe = 5 and flux passes through 5 teeth.

The reluctance of the air gap is inversely proportional to the area corresponding to 5 teeth.

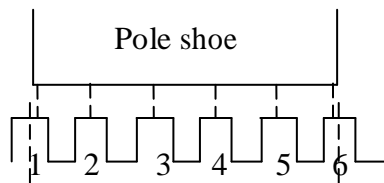

Number of teeth/pole shoe = 5 and flux passes through 6 teeth when the armature is moved half tooth pitch to the right. The reluctance of the air gap is inversely proportional to the area corresponding to 6 teeth. The reluctance in this case is less and the flux is more compared to the former case. Therefore, the flux pulsates i.e. Varies in magnitude.

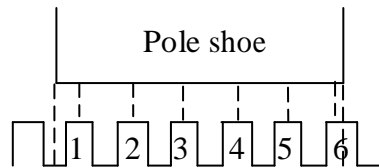

Number of teeth/pole shoe =  $(5 + 0.5)$  and flux passes through 6 teeth.

The reluctance of the air gap is inversely proportional to the area corresponding to 6 teeth.

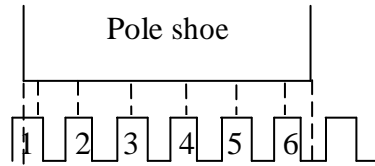

Number of teeth/pole shoe =  $(5+0.5)$  and flux passes through 6 teeth when the armature is moved half tooth pitch to the right. The reluctance of the air gap is inversely proportional 6 teeth as before. The reluctance and the flux in both the cases remains the same in all positions of the armature. However, the reluctance and the flux under the tips of the pole are not the same for all the positions of armature. Therefore when the armature rotates the flux under the pole oscillates between the pole tips. This produces ripple in the voltage induced in the conductors moving under poles.

The flux pulsation under inter pole causes the sparking. A small tooth pitch helps to reduce the effect of armature slots upon the inter poles.

To obtain good commutation, the flux density in the air gap must decrease gradually from maximum value under the center of the pole to zero on the center line between two poles, and the flux densities near the neutral point must be low. A field form that drops off rapidly from maximum value to zero not only leads to commutation difficulties but may also give rise to noises in machines with slotted armatures. In order to achieve good commutation the pole shoe is designed to cover only certain percentage of the pole pitch.

The circumferential distance covered by the pole shoe on the armature surface is called the pole arc. The ratio of the pole arc to pole pitch is called per unit embrace or enclosure. That is, per

unit enclosure  $\psi = \frac{\text{Pole arc}}{\text{Pole pitch}} \leq 1.0$ . In practice  $\psi$  lies between 0.6 and 0.7.

In general, the slots between pole tips of two adjacent pole tips i.e.  $(1-\psi) \frac{S}{P}$  should be at

least 3, or

$$(1-\psi) \frac{S}{P} \geq 3$$

If  $\Psi=0.66$ , the number of slots per pole,

$$\frac{S}{P} \geq \frac{3}{(1-0.66)} \geq 8.82 \text{ or say } 9$$

### Rule to select the number of slots

1. From satisfactory commutation point of view, minimum number of slots / pole can be taken as 9.
2. To avoid flux pulsation, slots / pole should be an (integer + 1/2).
3. Slot pitch  $\lambda_s = \pi D/S$  can assumed to lie between 2.5 and 3.5 cm.
4. For a lap winding, number of slots may be multiple of number of poles P or number of pair of poles p ( $p=P/2$ ) so that equalizer rings can used.
5. For a wave winding, number of slots should not be a multiple of number of pair of poles p and should lead to a particular number of coils that makes the commutator or average pitch  $Y_c = [(C \pm p \times k) / p]$ , an integer.

[Note: With a particular number of coils, if  $Y_c$  does not work out to be an integer, then a wave winding can not be realized. However, it be realized by considering one of the coils as dummy. In that case the number of commutator segments is equal to the number of active coils or (total number of coils – 1). A dummy coil is coil which is electrically inactive. It is made inactive by not connecting its coil ends to the commutator segments. Against its absence, its presence ensures that all the slots are completely filled and armature is mechanically balanced.

$$\begin{aligned} \text{Number of coils } C &= \text{number of slots } S \times \text{number of coil sides / layer} \\ &= \text{number of coil sides} / 2 \\ &= \frac{\text{Total number of armature conductors } Z}{\text{number of conductors / coil}} \\ &= \frac{Z}{2 \times \text{conductors / coil side}} \\ &= \frac{Z}{2 \times \text{number of turns / coil}} \end{aligned}$$

In general the number of commutator segments is equal to the number of active coils. ]

### Size of the armature slots

Width and depth of the slot depends on the number of conductors per slot, cross sectional area of the conductor, rated voltage etc.

[Note: The insulation within the slot can be roughly divided into two main categories: ground wall or slot liner and that associated with conductor insulation and their arrangement in the slot.

**Slot liner:** Protects the winding insulation against any mechanical damage due to roughness of the slot walls and insulate the armature. It also galvanically separates the coil from the iron core of the machine. Materials used generally are Leatheroid, Melinex® polyester films, horn fiber etc.

**Separator:** Separates and insulates the two layers. Leatheroid, horn fiber, micanite etc., are used.

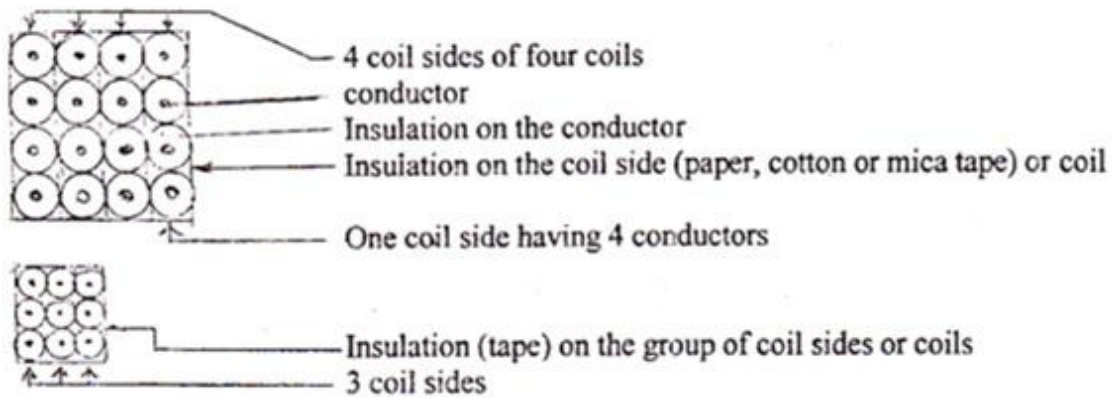

**Conductor insulation:** Separates the wires and turns of a coil. Usually, standards are not as high for conductor insulation as they are for slot liner insulation, and therefore the former is usually notably thinner than the latter. Consequently a conductor or turn to turn insulation is usually, and in small machines in particular, a varnishing on the wire.]

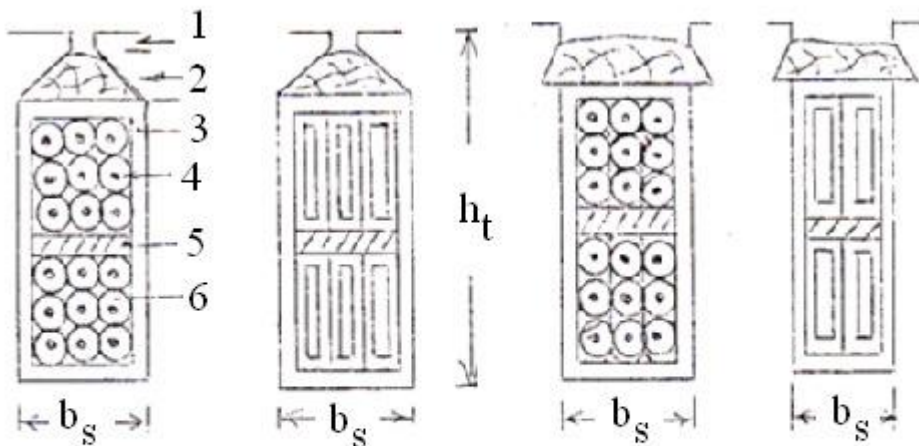

1. Lip
2. Wedge
3. Slot liner
4. Conductor
5. Separator
6. Insulation on the conductor

Slot width  $b_s$  = (Width or diameter of the conductor + insulation on it) number of conductors along the width of the slot + (insulation over the coil or group of coils + slot liner + clearance)

Slot depth  $h_t$  = (Depth or diameter of the conductor + insulation on it) number of conductors along the depth of the slot + (insulation over the coil or group of coils + separator + slot liner + clearance) + wedge 3 to 5 mm + lip 1 or 2 mm.

For a preliminary design, widthwise sum of insulation over the coil or group of coils, slot liner and clearance can be taken as 1.5mm and depth wise sum of insulation over the coil or group of coils, separator, slot liner and clearance 4mm.

For a given slot pitch, as the slot width and depth increases, the tooth width becomes less and it will be mechanically weak. In general  $b_s$  should not be greater than 60% of slot pitch. The slot width and depth must be so selected that the flux density in the tooth at one third height from the root of the tooth  $B_{t1/3}$  is not greater than 2.1T. That is

$$B_{t1/3} = \frac{\phi}{b_{t1/3} L_i \times S/P} \text{ should not be more than } 2.1T$$

$b_{t1/3}$  = width of the armature tooth at 1/3 height from the root of the tooth

$$\begin{aligned} &= \lambda_{s1/3} - b_s \\ &= \frac{\pi (D - 4/3 h_t)}{S} - b_s \end{aligned}$$

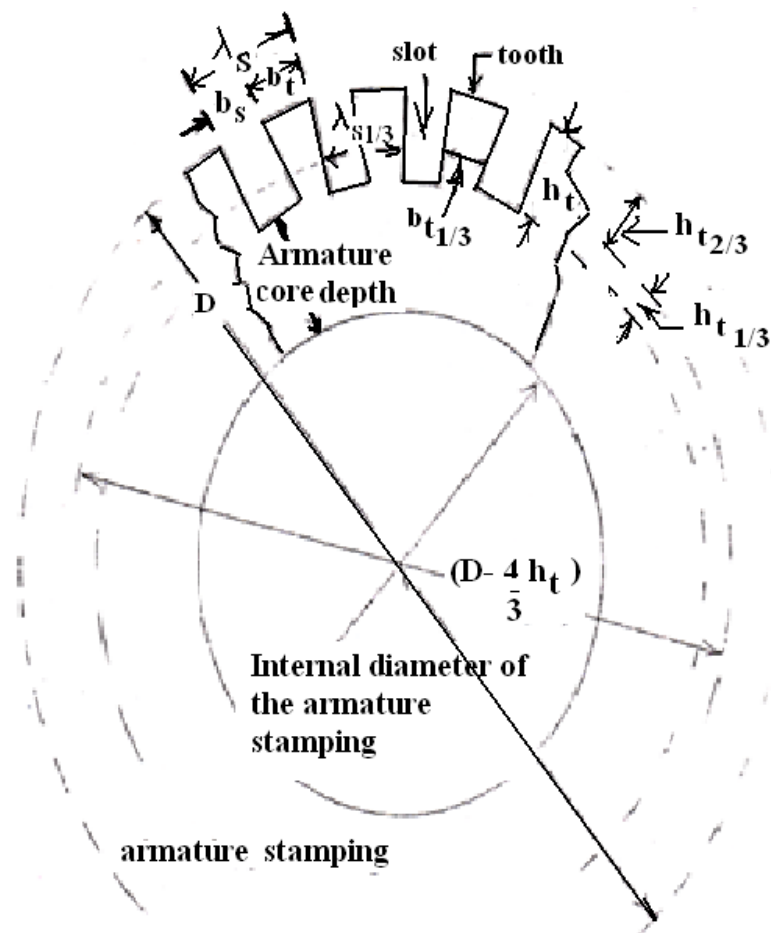

**Armature core depth  $d_c$  •**

Flux density in the armature

$$\text{value of } B_c, d_c = \frac{\phi / 2}{B_c L_i}$$

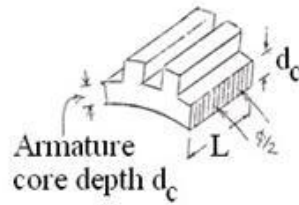

between (1.0 and 1.5)T. With an assumed



Therefore the internal diameter of the armature =  $(D - 2h_t - 2d_c)$ .

\*\*\*\*\*



## Problems on Armature of a DC machine

### Example: 1

Determine the number of poles, armature diameter and core length for the preliminary design of a 500kW, 400V, 600 rpm, dc shunt generator assuming an average flux density in the air gap of 0.7 T and specific electric loading of 38400 ampere- conductors per metre. Assume core length/ pole arc = 1.1. Apply suitable checks.

$$\text{Armature current } I_a = I_L + I_{sh} = \frac{\text{Output in watts}}{\text{terminal voltage}} = \frac{500 \times 10^3}{400} = 400\text{A}$$

In order that the current/path is not more than 200A, a lap winding is to be used. The number of parallel paths required is

$$A = \frac{1250}{200} = 6.25$$

Since the number of parallel paths cannot be a fraction as well an odd integer, A can be 6 or 8. Let it be 6. (Note: A current/path of 200A need not strictly be adhered)

$$\text{Check: Frequency of the induced emf } f = \frac{PN}{120} = \frac{6 \times 60}{120} = 30\text{Hz and can be considered}$$

as the frequency generally lies between 25 and 50 Hz

$$D L = \frac{\text{kW}}{1.64 \times 10^{-4} B q N}$$

$$= \frac{500}{1.64 \times 10^{-4} \times 0.7 \times 38400 \times 600}$$

$$\approx 0.189\text{m}$$

Note: Since the capacity is considerable, power developed in the armature can be taken as power output for a preliminary design.

$$L = 1.1 \text{ pole arc} = 1.1 \Psi \tau$$

Since  $\Psi$  lies between 0.6 and 0.7, let it be 0.7.

$$\text{Since } \tau = \frac{\pi D}{P}, L = 1.1 \times 0.7 \times \frac{\pi D}{6} = 0.4D$$

$$D \times 0.4D = 0.189$$

$$D = \frac{0.189}{0.4} = 0.473\text{m}$$

$$D = 0.78\text{m and } L = 0.4 \times 0.78 \approx 0.31\text{m}$$

$$\text{Check: Peripheral velocity } v = \frac{\pi DN}{60} = \frac{\pi \times 0.78 \times 600}{60} = 24.2\text{m/s}$$

and is within the limits, i.e. 30 m/s.

### Example: 2

Determine the main dimensions of the armature core, number of conductors, and commutator segments for a 350kW, 500V, 450 rpm, 6pole shunt generator assuming a square pole face with pole arc 70% of the pole pitch. Assume the mean flux density to be 0.7T and ampere-conductors per cm to be 280.

$$D L = \frac{kW}{1.64 \times 10 B q N}$$

$$= \frac{350}{1.64 \times 10 \times 0.7 \times 280 \times 100 \times 450}$$

$$\approx 0.24\text{m}$$

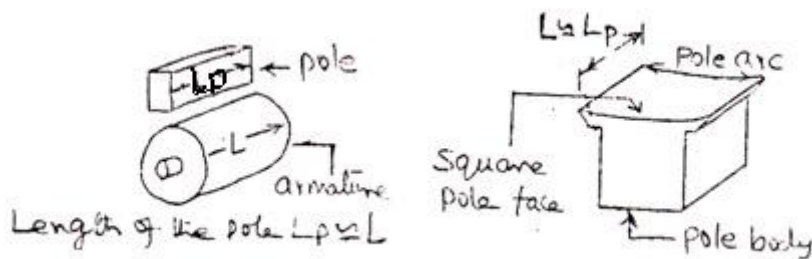

For a square pole face,  $L = \psi \tau = 0.7 \times \frac{\pi D}{6} = 0.36D$

$$D^3 = \frac{0.24}{0.37} = 0.654\text{m}^3$$

Therefore  $D = 0.87\text{m}$  and  $L = 0.37 \times 0.87 \approx 0.32\text{m}$

Since  $E = \frac{\phi Z N P}{60 A}$ , number of armature conductors  $Z = \frac{E 60 A}{\phi N P}$

$$\text{Flux per pole} = \frac{B_{av}\pi DL}{P} = \frac{0.7 \times \pi \times 0.87 \times 0.32}{6} = 0.1 \text{ Wb}$$

If a lap winding is assumed,  $A=P$  and therefore

$$Z = \frac{60 \times 500 \times 6}{0.1 \times 450 \times 6} = 666.6 \text{ and is not possible as the number of conductors must always be an even integer.}$$

The number of conductors can be 666 or 668. Let it be 666.

Number of coils = Number of commutator segments

$$= \frac{Z}{2 \times \text{turns per coil}} = \frac{666}{2 \times 1} = 333 \text{ if a single turn coil is assumed.}$$

### Example: 3

A design is required for a 50kW, 4pole, 600rpm, and 220V dc shunt generator. The average flux density in the air gap and specific electric loading are respectively 0.57T and 30000 ampere-conductors per metre. Calculate suitable dimensions of armature core to lead to a square pole face.

Assume that full load armature drop is 3% of the rated voltage and the field current is 1% of rated full load current. Ratio pole arc to pole pitch is 0.67.

$$D L = \frac{\text{kW}}{1.64 \times 10^{-3} B q N}$$

Note: Since data is available in the problem to calculate the power developed in the armature, the same may be obtained to substitute for kW.

Power developed in the armature in kW =  $E I_a \times 10^{-3}$

$$E = V + \text{voltage drop in the armature circuit} = 220 + 0.03 \times 220 = 226.6 \text{ V}$$

$$I_a = I_L + I_{Sh}$$

$$I_L = \frac{\text{Output in watts}}{\text{terminal voltage}} = \frac{50 \times 10^3}{220} = 227.3 \text{ A}$$

$$I_a = 227.3 + 0.01 \times 227.3 = 229.6 \text{ A}$$

$$\text{kW} = 226.6 \times 229.6 \times 10^{-3} = 52$$

$$D L = \frac{52}{1.64 \times 10 \times 0.57 \times 300 \times 600}$$

$$\approx 0.031\text{m}$$

For a square pole face,  $L = \Psi \tau = 0.67 \times \pi D/4 = 0.53D$

$$D^3 = \frac{0.031}{0.53} \text{ m}^3 \text{ and therefore } D=0.39\text{m and } L=0.53 \times 0.39 \approx 0.21\text{m}$$

#### Example: 4

Determine the diameter and length of the armature core for a 55kW, 110V, 1000rpm, and 4pole dc shunt generator. Assume:

Specific magnetic loading 0.5T, Specific electric loading 13000 ampere –turns,

Pole arc 70% of pole pitch and length of core about 1.1 times the pole arc, Allow 10A for field current and a voltage drop of 4V for the armature circuit.

Determine also the number of armature conductors and slots.

$$D L = \frac{\text{kW}}{1.64 \times 10 \text{ B } q \text{ N}}$$

Power developed in the armature in kW =  $E I_a \times 10$

$E = V +$  voltage drop in the armature circuit =  $110 + 4 = 114\text{V}$

$$I_a = I_L + I_{Sh} = \frac{55 \times 10}{110} + 10 = 510\text{A}$$

$$\text{kW} = 114 \times 510 \times 10^{-3} = 58.14$$

$$q = 13000 \times 2 = 26000$$

as q must be substituted in ampere conductors and one turn corresponds 2 conductors

$$D L = \frac{58.14}{1.64 \times 10 \times 0.5 \times 26000 \times 1000}$$

$$\approx 0.027\text{m}$$

since  $L = 1.1$  times pole arc,  $L = \Psi \tau = 1.1 \times 0.7 \times \pi D/4 = 0.4D$

$$D^3 = \frac{0.027}{0.6} \text{ m}^3 \text{ and therefore } D=0.36\text{m and } L=0.6 \times 0.36 \approx 0.22\text{m}$$

$$\text{Number of armature conductors } Z = \frac{60EA}{\phi NP}$$

$$\text{Flux per pole } \phi = \frac{B_{av} \pi DL}{P} = \frac{0.5 \times \pi \times 0.36 \times 0.22}{4} = 0.03 \text{ Wb}$$

If a lap winding is assumed,  $A=P$  and therefore

$$Z = \frac{60 \times 114 \times 4}{0.03 \times 1000 \times 4} \approx 228$$

Since the minimum number of slots per pole is 9 from commutation point of view, minimum number of slots for the machine is

$$= 9 \times 4 = 36 \text{ -----(1)}$$

Since slot pitch  $\lambda_s = \frac{\pi D}{S}$ , lies between 2.5 and 3.5 cm, the number of slots

$$\text{lies between } \frac{\pi \times 36}{3.5} \approx 32 \text{ and } \frac{\pi \times 36}{2.5} \approx 45 \text{ -----(2)}$$

From 1 and 2 the number of slots lies between 36 and 45.

Since a lap winding is assumed and for a lap winding the number of slots may be multiple of number of poles i.e. 6 or multiple of number of pair poles i.e. 3, let the number of slots  $S = 40$ .

Note: Since preliminary number of slots and conductors are known, actual number of conductors per slot and number of conductors can be calculated as detailed below.

$$\text{Conductors per slot} = \frac{228}{40} = 5.7 \text{ and is not possible as Conductors per slot must always be}$$

an even integer for a double layer winding. Since only double layer winding is for dc machines,

let the number Conductors per slot be 6. Therefore  $Z_{\text{revised}} = 40 \times 6 = 240$ .

### Example: 5

For a preliminary design of a 50hp, 230V, 1400 rpm dc motor, calculate the armature diameter and core length, number of poles and peripheral speed. Assume specific magnetic loading 0.5T, specific electric loading 25000 ampere- conductors per meter, efficiency 0.9.

$$I_a = I_L - I_{sh} \approx I_L = \frac{\text{Input in watts}}{\text{Voltage}} = \frac{h8 \times 746 \div 9}{;} = \frac{50 \times 747}{0.9 \times 230} = 180.2 \text{ A}$$

For this armature current, a lap or wave winding can be used. Since minimum number

of paths and poles is two, 2 poles are sufficient for the machine. However, to gain more advantages of more number of poles, let  $P=4$ .

$$C = \frac{4 \times 1400}{120} = 46.7, \text{ within the limits.}$$

$$D^2L = \frac{\text{kW}}{1.64 \times 10^{-4} B_{av} q N}$$

Power developed in the armature

$$= A \frac{1 + 29}{39} B \text{ output power}$$

$$= A \frac{1 + 2 \times 0.9}{3 \times 0.9} B 50 \times 0.746 = 38.7 \text{ kW}$$

$$D^2L = \frac{38.7}{1.64 \times 10^{-4} \times 0.5 \times 25000 \times 1400} = 0.0134 \text{ m}^3$$

Since  $\frac{C}{D}$  lies between 0.55 and 1.1, let it be 1.0.

$$\text{Therefore } L = \tau = \frac{H I}{4} = 0.785 I$$

$$I = \frac{0.0134}{0.785} = 0.017 \text{ m}^3 \text{ and } D = 0.26 \text{ m, } L = 0.785 \times 0.26 \approx 0.2 \text{ m}$$

$$\text{Peripheral velocity } v = \frac{H I}{60} = \frac{H \times 0.26 \times 1400}{60} \approx 19 \text{ m/s}$$

### Example: 6

Calculate the armature diameter and core length for a 7.5kW, 4pole, 1000rpm, and 220V shunt motor. Assume:

Full load efficiency = 0.83, field current is 2.5% of rated current. The maximum efficiency occurs at full load.

$$D^2L = \frac{\text{kW}}{1.64 \times 10^{-4} B_{av} q N}$$

Power developed in the armature

= Electrical output of the motor + Iron, friction and windage losses

$$\text{Electrical input to the motor} = \frac{\text{output}}{\eta} = \frac{7.5 \times 10^3}{0.83} \approx 9036 \text{ W}$$

$$\text{Losses at full load} = Q \frac{R_s}{s} T \text{ output} = Q \frac{R_{u,v}}{u,v} T \times 7.5 \times 10^3 = 1536 \text{ W}$$

Since efficiency is maximum at full load and at maximum efficiency, the variable loss is equal to constant loss,

$$\text{Variable loss} = \text{armature copper loss} = \frac{1536}{2} \approx 768 \text{ W}$$

$$\text{Field copper loss} = I_{sh}^2 Z_{fh}$$

$$I_{sh} = 0.025 \text{ full load current} = 0.025 \times \frac{7.5 \times 10^3}{0.83 \times 220} = 1.03 \text{ A}$$

$$\text{Field copper loss} = 220 \times 1.03^2 = 226.6 \text{ W}$$

$$\text{Power developed in the armature} = 9036 - 768 - 226.6 = 8041.4 \text{ W}$$

OR

$$\text{Iron, friction and windage losses} = \text{Constant losses} - \text{field copper loss}$$

$$= 768 - 226.6 = 541.4 \text{ W}$$

$$\text{OR Power developed in the armature} = 7500 + 541.4 = 8041.4 \text{ W}$$

Since specific magnetic loading lies between 0.45 and 0.75 T, let it be 0.6 T.

Since specific electric loading lies between 15000 to 50000 ampere-conductors, let it be 30000.

$$D^2 L = \frac{8.041}{1.64 \times 10^{-4} \times 0.6 \times 30000 \times 1000} = 0.0027 \text{ m}^3$$

Since  $\frac{C}{D}$  lies between 0.55 and 1.1, let it be 1.0.

$$\text{Therefore } L = \tau = \frac{H I}{4} = 0.785 I$$

$$I = \frac{0.0027}{0.785} = 0.0343 \text{ m}^3 \quad \text{and} \quad D = 0.33 \text{ m}, \quad L = 0.785 \times 0.33 \approx 0.26 \text{ m}$$

0.785



List the design details of armature winding suitable for a 35hp, 4pole, 500rpm, and 230V, motor. Flux per pole 0.028Wb.

Details of the winding : Type of winding, number of slots, number of conductors, cross-sectional area of conductor, number of coils, back pitch, front pitch etc.

$$I_a \approx \frac{\text{Input in watts}}{\text{Voltage}} = \frac{35 \times 746}{0.9 \times 230} = 126.1 \text{ A with the assumption, efficiency is 0.9.}$$

For the armature current of 126.1A, a lap or wave winding can be used. Let a wave winding be used.

$$\text{Number of armature conductors } Z = \frac{60EA}{\phi NP} = \frac{60 \times 230 \times 2}{0.028 \times 500 \times 4} \approx 492$$

Since the minimum number of slots per pole is 9 from commutation point of view, minimum number of slots for the machine is  $9 \times 4 = 36$ .

[Note: Since the diameter of the armature is not known, number of slots from the slot pitch consideration cannot be fixed. It is not very much essential to determine D either from D L product or peripheral velocity and then fix number of the slots. Even the condition minimum, 9 slots per pole need not be satisfied, as it is only a guiding figure in fixing the number of slots for the machine. For a preliminary design, a number, around the minimum number of slots can be selected.]

Since for a wave winding, the number of slots should not be a multiple of pair of poles i.e.  $p = 2$ , let the number of slots be 43.

Conductors per slot =  $\frac{492}{43} \approx 11.5$  and is not possible. Let the number Conductors per slot be 12.

$$\text{Therefore } Z_{\text{revised}} = 12 \times 43 = 516$$

$$\text{Commutator or average pitch } Y_c \text{ for simplex wave winding} = \frac{C \pm 1}{p}$$

and must be an integer

$$\text{Number of coils } C = \frac{Z}{2 \times \text{turns per coil}} = \frac{516}{2 \times 1} = 258 \text{ with single turn coils } Y_{\text{assumed}} \setminus.$$

$C = 258$  leads to an asymmetrical, unbalanced or a wave winding with a dummy coil because 258 is a multiple of number of pair of poles.

If a two turn coil is assumed, then the number coils will be  $\frac{516}{2 \times 2} = 129$  and leads to a

symmetrical, balanced or a wave winding without a dummy coil because 129 is not a multiple of number of pair of poles.

$$\text{Therefore } Y_C = \frac{C+1}{p} = \frac{129+1}{2} = 65 \text{ or } 64$$

If  $Y_C = 65$ ,  $Y_B = 65$  and  $Y_F = 65$

If  $Y_C = 64$ ,  $Y_B = Y_C \pm 1 = 64 \pm 1 = 63$  or  $65$

With  $Y_B = 63$ ,  $Y_F = Y_B \pm 2 = 63 \pm 2 = 65$  so that  $\frac{Y_B + Y_F}{2} = Y_C = 64$

With  $Y_B = 65$ ,  $Y_F = Y_B \pm 2 = 65 \pm 2 = 63$  so that  $\frac{Y_B + Y_F}{2} = Y_C = 64$

Cross-sectional area of the conductor  $a = \frac{I_a}{A \delta} = \frac{126.1}{2 \times 5} = 12.61 \text{ mm}^2$

For the above area a round or rectangular conductor can be used.

### Example: 8

For a preliminary design of a 1500kW, 275V, 300rpm, dc shunt generator determine the number of poles, armature diameter and core length, number of slots and number of conductors per slot. Assume:

Average flux density over the pole arc as 0.85T, Output coefficient 276, Efficiency 0.91. Slot loading should not exceed 1500A.

$$I_a = I_L + I_{Sh} \approx I_L = \frac{1500 \times 10}{275} = 5454.5 \text{ A}$$

In order that the current per path is not more than about 200A, a simplex wave winding cannot be used. Obviously, a lap winding has to be used having number of parallel paths

$$A = \frac{5454.5}{200} \approx 27.27.$$

Since the number of parallel paths must be an even integer, it can be 26 or 28. Let  $A = 28$ . Therefore, with a simplex lap winding considered  $P = 28$ .

Check:  $f = \frac{h \cdot i}{R \cdot U} = \frac{V \times U \cdot U}{R \cdot U} = 70\text{Hz}$  and is on the higher side as frequency generally considered between 25 and 50Hz. In order to reduce the frequency and to have  $A = 28$ , a duplex lap winding can be used with  $P = 14$  and  $f = 35\text{Hz}$ .

$$D L = \frac{\text{kW}}{1.64 \times 10^{-4} B q N} = \frac{\text{kW}}{C_o N}$$

$$\text{Power developed in the armature in kW} = \frac{\text{output}}{9} = \frac{1500}{0.91} = 1648.1$$

[Note: a) When the speed is in rpm in the expression,  $D L = \frac{\text{kW}}{C_o N}$ , the output coefficient

$$C_o = 1.64 \times 10^{-4} B q \text{ lies between}$$

$$1.64 \times 10^{-4} \times 0.45 \times 15000 = 1.0 \text{ and } 1.64 \times 10^{-4} \times 0.75 \times 50000 = 6.0.$$

On the other hand if the speed is in rpm,  $C_o = H \times 10^{-4} B q$  lies between

$$H \times 10^{-4} \times 0.45 \times 15000 = 60 \text{ and } H \times 10^{-4} \times 0.75 \times 50000 = 360.$$

Since the given value of  $C_o$  lies in the range of 60 and 360, the speed must be in rps when substituted in the output equation.]

$$D L = \frac{1648.4}{276 \times \frac{U \cdot U}{10}} \approx 1.2\text{m}$$

[Note: In order to split up  $D L$  product into  $D$  and  $L$ , a value for  $\frac{n}{\phi}$  ratio or peripheral velocity has to be assumed. ]

$$\text{Let } L = \tau, \text{ Therefore, } L = \frac{\pi D}{14} = 0.23D$$

$$D^3 = \frac{1.2}{0.23} = 5.2\text{m}^3 \text{ and therefore } D = 1.7\text{m} \text{ and } L = 0.23 \times 1.7 \approx 0.39\text{m}$$

Since the minimum number of slots per pole is 9 from commutation point of view, minimum number of slots for the machine is

$$= 9 \times 14 = 126 \text{ -----(1)}$$

Since slot pitch  $\lambda_p = \frac{H}{q}$ , lies between 2.5 and 3.5 cm, the number of slots

lies between  $\frac{\pi \times 170}{3.5} \approx 152$  and  $\frac{\pi \times 170}{2.5} \approx 214$  -----(2)

From 1 and 2 the number of slots lies between 152 and 214.

Since a lap winding is assumed and for a lap winding the number of slots may be multiple of number of poles i.e. 14 or multiple of number of pair poles i.e. 7, let the number of slots  $S = 196$ .

Number of armature conductors  $Z = \frac{E60A}{\phi NP}$

$$\begin{aligned} \text{Flux per pole } \phi &= \frac{B_{av} \pi DL}{P} = \frac{\Psi B_g \pi DL}{P} \\ &= \frac{0.7 \times 0.85 \times \pi \times 1.7 \times 0.39}{4} = 0.089 \text{ Wb with the assumption } \Psi = 0.7 \end{aligned}$$

$$Z = \frac{60 \times 275 \times 28}{0.089 \times 300 \times 14} \approx 1236$$

Conductors per slot =  $\frac{1236}{196} = 6.3$  and is not possible as Conductors per slot must always be

an even integer for a double layer winding. Let the number Conductors per slot be 6.

Therefore  $Z_{\text{revised}} = 196 \times 6 = 1176$ .

Slot loading = conductors per slot  $\times$  current through the conductor i.e.  $\frac{I_a}{A}$

$$= 6 \times \frac{5454.5}{28} = 1168.8 < 1500 \text{ and the condition is satisfied.}$$

### Example: 9

A 150hp, 500V, 6pole, 450rpm, dc shunt motor has the following data.

Armature diameter = 54cm, length of armature core = 24.5cm, average flux density in the air gap = 0.55T, number of ducts = 2, width of each duct = 1.0cm, stacking factor = 0.92.

Obtain the number of armature slots and work the details of a suitable armature winding. Also determine the dimensions of the slot. The flux density in the tooth at one third height from the root should not exceed 2.1T.

$$I_a = \frac{hp \times 746}{\eta \times V} = \frac{150 \times 746}{0.9 \times 500} = 248.7 \text{ A}$$

For this armature current, a lap or wave winding may be used. Let a lap winding be used.

Since the minimum number of slots per pole is 9 from commutation point of view, minimum number of slots for the machine is

$$= 9 \times 6 = 54 \text{ -----(1)}$$

Since slot pitch  $\lambda_s = \frac{\pi D}{S}$ , lies between 2.5 and 3.5 cm, the number of slots

$$\text{lies between } \frac{H \times 54}{3.5} \approx 48 \text{ and } \frac{H \times 54}{2.5} \approx 68 \text{ -----(2)}$$

From 1 and 2 the number of slots lies between 54 and 68.

Since a lap winding is assumed and for a lap winding the number of slots may be multiple of number of poles i.e. 6 or multiple of number of pair poles i.e. 3, let the number of slots  $S = 60$ .

Details of winding: Type of winding (already fixed), number of slots (also fixed), number of conductors, cross-sectional area of the conductor, back pitch, front pitch etc.

$$\text{Flux per pole } \phi = \frac{B_{av} \pi D L}{P} = \frac{0.55 \times \pi \times 0.54 \times 0.245}{6} = 0.038 \text{ Wb}$$

$$\text{since a lap winding is assumed, } Z = \frac{60 \times 500 \times 6}{0.038 \times 450 \times 6} \approx 1754$$

$$\text{Conductors per slot} = \frac{1754}{60} = 29.2 \text{ and is not possible}$$

let the number Conductors per slot be 30. Therefore  $Z_{\text{revised}} = 30 \times 60 = 1800$ .

$$\text{Back pitch } Y_B = \frac{Z}{P} \pm K = \frac{1800}{6} \pm K = \frac{1800}{6} \pm 1 = 301 \text{ say.}$$

$$\text{Front pitch } Y_F = Y_B \pm 2 = 301 \pm 2 = 299 \text{ for a progressive winding}$$

Since the current density lies between 4.5 and 7 A/mm<sup>2</sup>, let it be 5 A/mm<sup>2</sup>

$$\text{Cross-sectional area of the conductor } a = \frac{Z_t}{uv} = \frac{248.7}{6 \times 5} = 8.3 \text{ mm}^2$$

Since  $a$  is less than 10 mm<sup>2</sup>, let a round conductor be used of bare diameter

$$w \frac{4x}{H} = w \frac{4 \times 8.3}{H} = 3.25\text{mm}$$

Since only double layer winding is used for a dc machine, number of conductor per layer is  $(30/2) = 15$  and can be arranged in any one of the following ways.

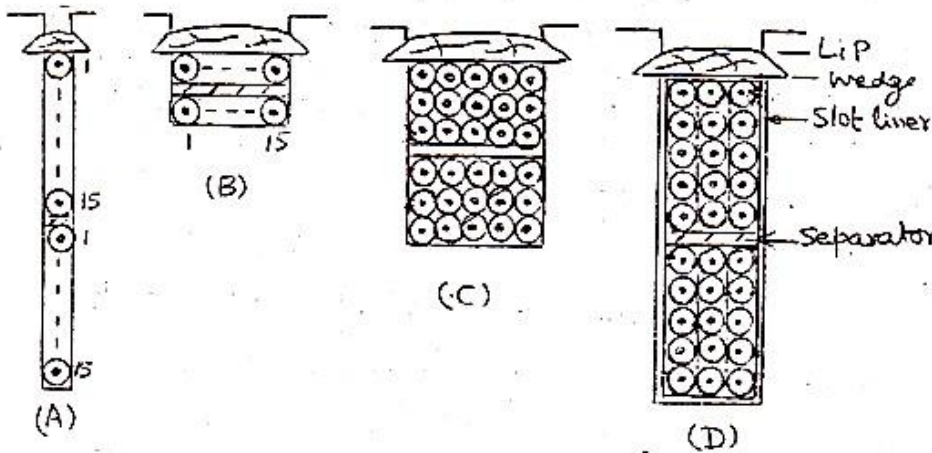

Conductor of 3.25mm diameter.  
 Insulation on the conductor, enamel coating of 0.075mm thick.

Insulation on the coil side

- (A)- 15 conductors are arranged one below the other in each layer. Slot is not proportionate.
  - (B)- 15 conductors are arranged one beside the other in each layer. Slot is not proportionate.
  - (C) and (D) - arrangement of conductors as shown in (C) or (D), leads to proportionate slots
- If the conductors are arranged as shown in (D), then,

Slot width  $b_s = (\text{diameter of the conductor} + \text{insulation on it}) \times \text{number of conductors along the}$

slot width + (insulation over the coil side or group of coil sides + slot liner  
+ clearance)

$$= (3.25 + 2 \times 0.075)3 + 1.5$$

$$= 11.7\text{mm}$$

Slot depth  $h_t = (\text{diameter of the conductor} + \text{insulation on it}) \times \text{number of conductors along the}$

slot depth + (insulation over the coil side or group of coil sides + slot liner

+ separator + clearance) + wedge 3 to 5 mm + lip 1 or 2mm.

$$= (3.25 + 2 \times 0.075)10 + 4 + 4 + 2$$

$$= 44\text{mm}$$

Flux density in the tooth at one third height from the root of the tooth  $y_{z_{t:1}} = \frac{\phi}{\sim_{z_{t:1}} \times C \times \frac{\epsilon}{\epsilon_0}}$

width of the tooth at  $\frac{1}{3}$  height from the root of the tooth  $\sim_{z_{t:1}}$

$$= \frac{H Q \mathbf{I} - \frac{\epsilon}{\epsilon_0} T}{q} - \sim_p = \frac{H Q 54 - \frac{\epsilon}{\epsilon_0} T}{60} - 1.17 = 1.35\text{cm}$$

Net iron length  $C = \dots (L - \dots \sim_p) = 0.9(24.5 - 2 \times 1) = 20.7\text{cm}$

$$\hat{h} - \hat{\epsilon} - \hat{y}_{z_{t:1}} = \frac{0.038}{0.0135 \times 0.207 \times \frac{10}{1}} = 1.36\hat{\epsilon}$$

$y_{z_{t:1}} = 1.36\hat{\epsilon}$  is the average flux density in the tooth

with assumption, that the flux per pole is uniformly distributed in all the teeth under one pole.

However because of higher value of flux under pole arc, the flux density in the tooth will be

more than the average value. Thus maximum value of the average flux density ( $B_{t_{1:3}} \text{ max}$ )

can be as  $\frac{A B_{t_{1:3}} B}{\text{Field form factor or per unit enclosure}}$

If per unit enclosure  $\psi$  is taken as 0.7, then,  $(B_{t_{1:3}})_{\max} = \frac{1.36}{0.7} = 1.94T$  and less than 2.1T

### Example:10

A 250kW, 500V, 6pole, 600rpm, dc generator is built with an armature of 0.75m and core length of 0.3m. The lap connected armature has 720 conductors. Using the data obtained from this machine, determine the armature diameter, core length, number of armature slots, armature conductors and commutator segments for a 350kW, 440V, 720 rpm, 6pole dc generator.

Assume a square pole face with ratio pole arc to pole pitch equal to 0.66. The full load efficiency is 0.91 and the internal voltage drop is 4% of rated voltage. The diameter of commutator is 0.7 of armature diameter. The pitch of the commutator segments should not be less than 4mm. The voltage between adjacent segments should not exceed 15V at no load.

[Note: In order to determine the details of 350kW machine,  $B_{av}$  and  $q$  are required. Since the data of 250kW machine is to be used for the second machine,  $B_{av}$ ,  $q$  and  $C_o$  are same for both the machines. The data square pole, efficiency, voltage drop can assumed to be applicable to both machines.]

I machine:

$$q = \frac{I_a Z}{A \pi D}$$

$$I_a = \frac{\text{Power developed in the armature}}{\text{induced emf}}$$

$$\text{Power developed in the armature} = \frac{\text{Output}}{\text{Efficiency}} = \frac{250}{0.91} = 274.7 \text{ kW}$$

$$\text{emf induced } E = 500 + 0.04 \times 500 = 520 \text{ V}$$

$$Z_t = \frac{274.7 \times 10}{520} = 528.3 \text{ A}$$

$$\% = \frac{528.3 \times 720}{6 \times H \times 0.75} \approx 26906 \text{ ampere-conductors per meter}$$

$$B_{av} = \frac{P \phi}{\pi D L}$$

$$\phi = \frac{60 E A}{Z N P} = \frac{60 \times 520 \times 6}{720 \times 600 \times 6} \approx 0.072 \text{ Wb}$$

$$6 \times 0.072$$



$$B_{av} = \frac{\quad}{\pi \times 0.75 \times 0.3} = 0.61T$$

OR

$$y_{t\ddagger} = \frac{\check{S} <}{1.64 \times 10^{\%> \mathbf{I} C}} = \frac{274.7}{1.64 \times 10^{\%> \times 26906 \times 600 \times 0.75 \times 0.3}} = 0.61\ddagger$$

II machine:

$$\mathbf{I} C = \frac{\check{S} <}{1.64 \times 10^{\%> y_{t\ddagger} \%>}} = \frac{p}{1.64 \times 10^{\%> \times 0.61 \times 26906 \times 720}} \approx 0.195$$

For a square pole face,  $L = \Psi \tau = 0.66 \times \pi D / 6 = 0.35D$

$$D^3 = \frac{0.195}{0.35} = 0.564 \text{m}^3$$

Therefore  $D = 0.83 \text{m}$  and  $L = 0.35 \times 0.83 \approx 0.29 \text{m}$

Since the minimum number of slots per pole is 9 from commutation point of view, minimum number of slots for the machine is

$$= 9 \times 6 = 54 \text{ -----(1)}$$

Since slot pitch  $\lambda_s = \frac{\pi D}{S}$ , lies between 2.5 and 3.5 cm, the number of slots

$$\text{lies between } \frac{H \times 83}{3.5} \approx 74 \text{ and } \frac{H \times 83}{2.5} \approx 104 \text{ -----(2)}$$

From 1 and 2 the number of slots lies between 74 and 104.

If a lap winding is assumed then for a lap winding the number of slots may be multiple of number of poles i.e. 6 or multiple of number of pair poles i.e. 3, let the number of slots  $S = 78$

$$\text{Number of armature conductors } Z = \frac{E60A}{\phi N P}$$

$$\text{emf induced } E = 440 + 0.04 \times 440 = 457.6 \text{V}$$

$$\text{Flux per pole } \phi = \frac{B_{av} \pi D L}{P} = \frac{0.61 \times \pi \times 0.83 \times 0.29}{6} = 0.078 \text{Wb}$$

$$Z = \frac{60 \times 457.6 \times 6}{0.078 \times 720 \times 6} \approx 488$$

$$\text{Conductors per slot} = \frac{488}{78} = 6.2 \text{ and is not possible. Let it be } 6$$

$$Z_{\text{revised}} = 78 \times 6 = 468$$

$$\text{Conductors /layer} = \frac{6}{3} = 3$$

Three conductors /layer is possible only with 3 coil sides/layer of single turn coil or one coil

Side/layer of 3 turn coil. If a single turn coil is assumed, then the number of coils =  $\frac{1V}{3} = 234$ .

There the number of segments = 234.

Check:

$$\text{Commutator segment pitch } \tau_c = \frac{\pi D_C}{\text{number of segments}}$$

$$\text{Commutator diameter } D_C = 0.7 \times 83 = 58.1 \text{ cm}$$

$$D_C = \frac{H \times 58.1}{234} = 0.78 \cdot m > 4 \text{ mm}$$

$$\text{Voltage between segments pitch} = \frac{\text{Open circuit voltage}}{\text{number of segments per pole}} = \frac{457.6}{234 \div 6} = 11.7 \text{ V} < 15 \text{ V}$$

**Example:11**

$$Z = \frac{30 \times 1000 \cdot \dots}{8} = \dots$$

$$h = \dots$$

$$\dots = \dots$$

$$\dots = \dots$$

$$\dots = \dots$$

$$8 = \dots$$

$$> = \dots$$

Assume the machine to be lap wound with single turn coils.

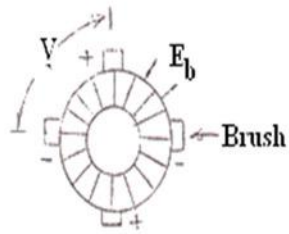

End view of the commutator





Current per brush arm should not exceed 400A

The mmf required for air gap is 50% of armature mmf and gap contraction factor is 1.15.

$$\text{Armature current } I_a \approx I_L = \frac{600 \times 10^3}{300} = 1200 \text{ A}$$

In order that current per path is not greater than 200A or current per brush arm is not greater than 400A, a lap winding is to be used having parallel paths,

$$u = \frac{1200}{200} = 6$$

Since for a simplex lap winding,  $A=P$ ,  $P=6$

$$\text{Check: Frequency } f = \frac{PN}{120} = \frac{6 \times 900}{120} = 45 < 50 \text{ Hz and the condition is satisfied.}$$

$$I C = \frac{\check{S} <}{1.64 \times 10 \quad y_{t+} \% >}$$

$$\text{Power developed in kW} = \frac{\text{Output}}{\eta} = \frac{600}{0.91} = 659.4$$

$$I C = \frac{659.4}{1.64 \times 10 \times 0.6 \times 3500 \times 900} = 0.213 \text{ m}$$

Since the peripheral velocity should not be greater than 40 m/s , let it be 36 m/s.

$$\text{Since } v = \frac{\pi DN}{60}, D = \frac{60v}{\pi N} = \frac{60 \times 36}{\pi \times 900} = 0.76 \text{ m}$$

$$L = \frac{0.213}{0.76^2} = 0.28 \text{ m}$$

Since the minimum number of slots per pole is 9 from commutation point of view, minimum number of slots for the machine is

$$= 9 \times 6 = 54 \text{ -----(1)}$$

Since slot pitch  $\lambda_s = \frac{\pi D}{S}$  , lies between 2.5 and 3.5 cm, the number of slots

$$\text{lies between } \frac{H \times 76}{3.5} \approx 68 \text{ and } \frac{H \times 76}{2.5} \approx 96 \text{ -----(2)}$$



Since for a lap winding the number of slots may be multiple of number of poles i.e. 6 or multiple of number of pair poles i.e. 3, let the number of slots  $S = 72$ .

$$\text{Number of armature conductors } Z = \frac{E60A}{\phi NP}$$

$$\phi = \frac{B_{av}\pi DL}{P} = \frac{0.6 \times \pi \times 0.76 \times 0.28}{6} = 0.067 \text{ Wb}$$

$$Z = \frac{60 \times 500 \times 6}{0.067 \times 900 \times 6} \approx 498$$

$$\text{Conductors per slot} = \frac{498}{72} = 6.9 \text{ and is not possible. Let it be 6.}$$

$$Z_{\text{revised}} = 72 \times 6 = 432$$

Check:

$$\text{Armature mmf per pole } AT_{a, \text{pole}} = \frac{I_a Z}{2AP} = \frac{1200 \times 432}{2 \times 6 \times 6} = 7200 \text{ A} < 7500 \text{ A}$$

and the condition is satisfied.

$$\text{Air gap mmf } A_g = 800000 \dots = 0.5 AT_{a, \text{pole}}$$

Carter's gap expansion or contraction coefficient  $k_c = 1.15$

$$\text{Maximum gap density } B_g = \frac{B_{av}}{\Psi} = \frac{0.6}{0.67} = 0.895 \text{ T}$$

### Design of Commutator and Brushes

The Commutator is an assembly of Commutator segments or bars tapered in section. The segments made of hard drawn copper are insulated from each other by mica or micanite, the usual thickness of which is about 0.8 mm. The number of commutator segments is equal to the number of active armature coils.

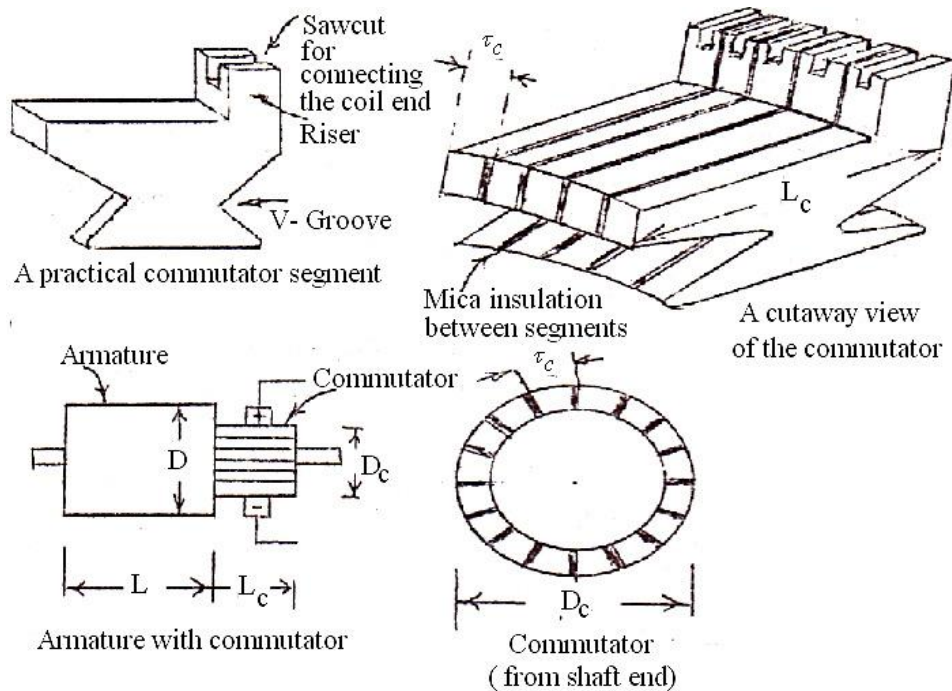

The diameter of the commutator will generally be about (60 to 80)% of the armature diameter. Lesser values are used for high capacity machines and higher values for low capacity machines.

Higher values of commutator peripheral velocity are to be avoided as it leads to lesser commutation time  $dt$ , increased reactance voltage  $RV = L \frac{di}{dt}$  and sparking commutation.

The commutator peripheral velocity  $v_c = \pi D_c N / 60$  should not as far as possible be more than about 15 m/s. (Peripheral velocity of 30 m/s is also being used in practice but should be avoided whenever possible.)

The commutator segment pitch  $\tau_c = (\text{outside width of one segment} + \text{mica insulation between segments}) = \pi D_c / \text{Number of segments}$  should not be less than 4 mm. (This minimum segment pitch is due to 3.2 mm of copper + 0.8 mm of mica insulation between segments.) The outer surface width of commutator segment lies between 4 and 20 mm in practice.

The axial length of the commutator depends on the space required

- 1) by the brushes with brush boxes
- 2) for the staggering of brushes
- 3) for the margin between the end of commutator and brush and
- 4) for the margin between the brush and riser and width of riser.

If there are  $n_b$  brushes / brush arm or spindle or holder, placed one beside the other on the commutator surface, then the length of the commutator  $L_C = (\text{width of the brush } w_b + \text{brush box thickness } 0.5 \text{ cm}) \text{ number of brushes / spindle} + \text{end clearance } 2 \text{ to } 4 \text{ cm} + \text{clearance for risers } 2 \text{ to } 4 \text{ cm} + \text{clearance for staggering of brushes } 2 \text{ to } 4 \text{ cm}.$

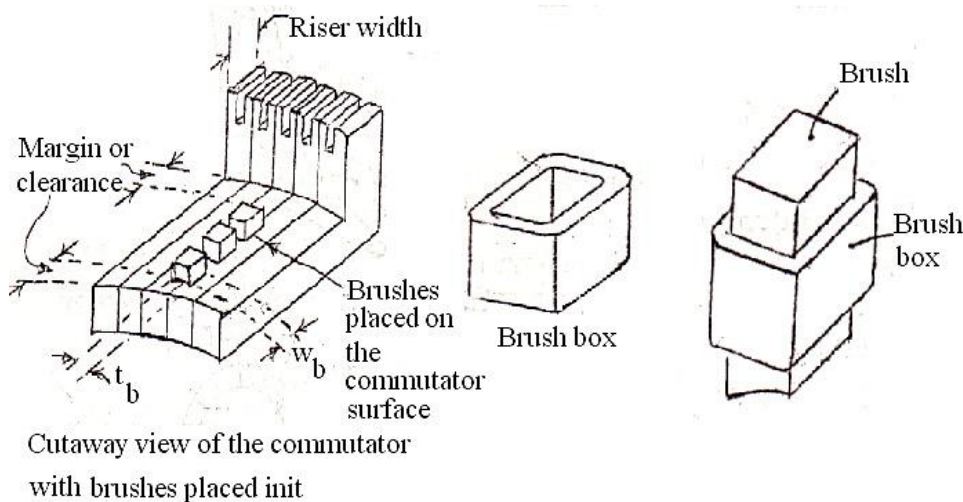

If the length of the commutator (as calculated from the above expression) leads to small dissipating surface  $\pi D_C L_C$ , then the commutator length must be increased so that the temperature rise of the commutator does not exceed a permissible value say  $55^\circ\text{C}$ .

The temperature rise of the commutator can be calculated by using the following empirical formula.

$$\theta^\circ\text{C} = \frac{120 \times \text{watt loss / cm}^2 \text{ of dissipating surface } \pi D_C L_C}{1 + 0.1 v_c}$$

The different losses that are responsible for the temperature rise of the commutator are (a) brush contact loss and (b) brush frictional loss.

$$\text{Brush contact loss} = \text{voltage drop / brush set} \times I_a$$

The voltage drop / brush set depend on the brush material – Carbon, graphite, electro graphite or metalized graphite. The voltage drop / brush set can be taken as 2.0 V for carbon brushes.

$$\begin{aligned} \text{Brush frictional loss (due to all the brush arms)} \\ = \text{frictional torque in Nm} \times \text{angular velocity} \end{aligned}$$

$$= \text{frictional force in Newton} \times \text{distance in metre} \times \frac{2\pi N}{60}$$

$$= 9.81 \mu P_b A_{\text{ball}} \times \frac{D_c}{2} \times \frac{2\pi N}{60} = 9.81 \mu P_b A_{\text{ball}} v_c$$

where  $\mu$  = coefficient of friction and depends on the brush material. Lies between 0.22 and 0.27 for carbon brushes

$P_b$  = Brush pressure in kg / m<sup>2</sup> and lies between 1000 and 1500

$A_{\text{ball}}$  = Area of the brushes of all the brush arms in m<sup>2</sup>

=  $A_b \times$  number of brush arms

=  $A_b \times$  number of poles in case of lap winding

=  $A_b \times 2$  or  $P$  in case of wave winding

$A_b$  = Cross-sectional area of the brush / brush arm

### Brush Details

Since the brushes of each brush arm collect the current from two parallel paths, current collected by each brush arm is  $\frac{2I_a}{A}$  and the cross-sectional area of the brush or brush arm or

holder or spindle  $A_b = \frac{2I_a}{A\delta_b}$  cm<sup>2</sup>. The current density  $\delta_b$  depends on the brush material and can be assumed between 5.5 and 6.5 A / cm<sup>2</sup> for carbon.

In order to ensure a continuous supply of power and cost of replacement of damaged or worn out brushes is cheaper, a number of subdivided brushes are used instead of one single brush. Thus if

- i)  $t_b$  is the thickness of the brush
- ii)  $w_b$  is the width of the brush and
- iii)  $n_b$  is the number of sub divided brushes

then  $A_b = t_b w_b n_b$

As the number of adjacent coils of the same or different slots that are simultaneously under going commutation increases, the brush width and time of commutation also increases at the same rate and therefore the reactance voltage (the basic cause of sparking commutation) becomes independent of brush width.

With only one coil under going commutation and width of the brush equal to one segment width, the reactance voltage and hence the sparking increases as the slot width decreases. Hence the brush width is made to cover more than one segment. If the brush is too wide, then those coils which are away from the commutating pole zone or coils not coming under the influence of inter pole flux and under going commutation leads to sparking commutation.

Hence brush width greater than the commutating zone width is not advisable under any circumstances. Since the commutating pole zone lies between (9 and 15)% of the pole pitch, 15% of the commutator circumference can be considered as the maximum width of the brush.

It has been found that the brush width should not be more than 5 segments in machines less than 50 kW and 4 segments in machines more than 50 kW.

The number of brushes / spindle can be found out by assuming a standard brush width or a maximum current / sub divided brush.

Standard brush width can be 1.6, 2.2 or 3.2 cm

Current/subdivided brush should not be more than 70A

Thus with the brush width assumed,  $n_b = \frac{A_b}{t_b w_b}$ . With the current / sub divided brush assumed

$$n_b = \frac{2I_a}{A \times 70} \text{ and } w_b = \frac{A_b}{t_b n_b}$$

Note :

#### A) Staggering of Brushes :

Because of the current flowing from commutator segments to the brush, copper is eaten away leading to formation of ridges between the subdivided brushes of the same brush arm. Since it is not possible to avoid eating away copper by the arc, eating away of copper must be made to take place over the entire axial length of the commutator to ensure uniform commutator surface. This is achieved by displacing all the positive brushes in one direction and all the negative brushes in the other direction or by staggering of brushes in pairs as shown below.

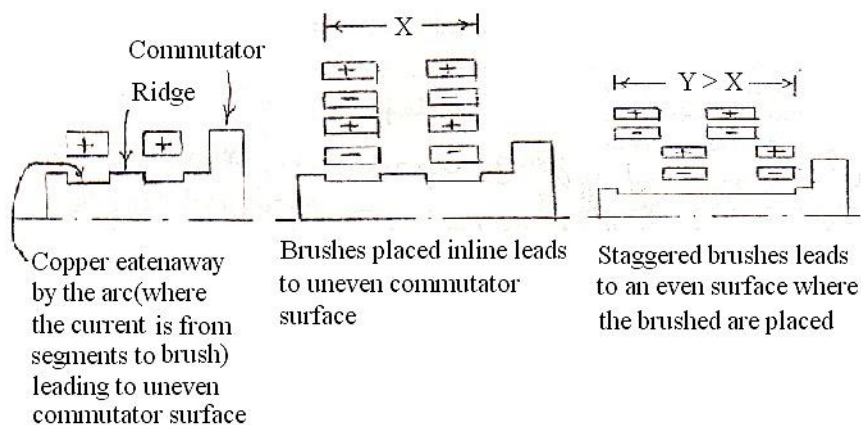

## B) Brush materials and their properties

Material	Peripheral velocity m/s	Current density in A/cm <sup>2</sup>	Voltage drop per brush set in volts	Coefficient of friction
Normal carbon	5 to 15	5.5 to 6.5	2.0	0.22 to 0.27
Soft graphite	10 to 25	9.0 to 9.5	1.6	0.12
Metalized graphite (copper carbon mixture)	5 to 15	15 to 16	0.24 to 0.35	0.16
Electro graphite (Graphitized by heating)	5 to 15	8.5 to 9.0	1.7 to 1.8	0.22

## C) Step by step design procedure of commutator and brushes

1) Diameter of the commutator  $D_C = (0.6 \text{ to } 0.8) D$  and must be such that the peripheral velocity of the commutator  $v_C = \pi D_C N / 60$  is not more than 15 m/s as far as possible.

2) The commutator segment pitch  $\tau_C = \pi D_C / \text{Number of segments}$  should not be less than 4 mm from the mechanical strength point of view.

3) The number of commutator segments is equal to number of active armature coils.

4) Length of the commutator  $L_C = (\text{width of the brush} + \text{brush box thickness } 0.5 \text{ cm}) \times \text{number of brushes} / \text{spindle } n_b + \text{end clearance } 2 \text{ to } 4 \text{ cm} + \text{clearance for risers } 2 \text{ to } 4 \text{ cm} + \text{clearance for staggering of brushes } 2 \text{ to } 4 \text{ cm}$ .

5) Cross-sectional area of the brush / spindle or arm or holder  $A_b = \frac{2 I_a}{A \delta_b} \text{ cm}^2$ . The current density in the brushes  $\delta_b$  lies between 5.5 and 6.5 A / cm<sup>2</sup> for carbon brushes.

6) Maximum thickness of the brush  $t_{b \text{ max}} = 4 \tau_C$  for machines greater than 50 kW  
 $= 5 \tau_C$  for machines less than 50 kW

7) With standard brush width  $W_b$  assumed, the number of brushes / spindle  $n_b$   
 $= \frac{A_b}{t_b W_b}$

8) Total commutator losses = Brush contact loss + Brush frictional loss  
 $= \text{voltage drop / brush set} \times I_a + 9.81 \mu P_b A_{ball} v_C$

where

voltage drop / set = 2.0 V for carbon brushes

$\mu$  = coefficient of friction and lies between 0.22 to 0.27 for carbon brushes

$P_b$  = Brush pressure and lies between 1000 and 1500 kg / m<sup>2</sup>

9) Temperature rise of the commutator

$\theta^{\circ}\text{C} = \text{Cooling coefficient} \times \text{watt loss} / \text{dissipating surface}$

$$= \frac{120}{1 + 0.1 v_C} \times \text{watt loss} / \text{cm}^2 \text{ of dissipating surface } \pi D_C L_C$$

10) Temperature rise should be less than about  $55^{\circ}\text{C}$ .

\*\*\*\*\*



## DESIGN OF COMMUTATOR AND BRUSHES

### Example.1

A 500kW, 500V, 375 rpm, 8 pole dc generator has an armature diameter of 110 cm and the number of armature conductor is 896. Calculate the diameter of the commutator, length of the commutator, number of brushes per spindle, commutator losses and temperature rise of the commutator. Assume single turn coils.

Diameter of the commutator  $D_C = (0.6 \text{ to } 0.8) D = 0.7 \times 110 = 77\text{cm}$

Length of the commutator  $L_C = (\text{width of the brush } W_b + \text{brush box thickness } 0.5 \text{ cm}) \text{ number of brushes / spindle } n_b + \text{end clearance } 2 \text{ to } 4 \text{ cm} + \text{clearance for risers } 2 \text{ to } 4 \text{ cm} + \text{clearance for staggering of brushes } 2 \text{ to } 4 \text{ cm}.$

$$\text{Armature current } I_a = \frac{\text{kW} \times 10^3}{V} = \frac{500 \times 10^3}{500} = 1000\text{A}$$

Note : An armature current of 1000 A obviously calls for a lap winding.

Cross-sectional area of the brush per spindle or brush arm or holder

$$A_b =$$

$\frac{2I_a}{A\delta_b}$  since the current density lies between 5.5 and 6.5 A/cm<sup>2</sup> for carbon brushes,

let it be 6 A/mm<sup>2</sup>

$$A_b = \frac{2 \times 1000}{8 \times 6} = 41.66 \text{ cm}^2$$

maximum thickness of the brush = 4  $\tau_C$

Commutator segment pitch  $\tau_C = \pi D_C / \text{Number of segments or coils}$

Number of coils =  $Z / 2 \times \text{number of turns per coil} = 896 / 2 \times 1 = 448$

$$\text{Therefore } \tau_C = \frac{\pi \times 77}{448} = 0.54 \text{ cm}$$

Maximum thickness of the brush =  $4 \times 0.54 = 2.16 \text{ cm}$

Let the thickness of the brush  $t_b = 2.0 \text{ cm}$

If a brush width of 2.2 cm (a standard value) is assumed then  $W_b = 2.2 \text{ cm}$

Therefore, number of brushes / spindle

$$n_b = \frac{A_b}{t_b W_b} = \frac{41.66}{2 \times 2.2} = 9.46 \text{ and is not possible}$$

Let the number of brushes / spindle be = 10

Therefore  $L_C = (2.2 + 0.5) 10 + 2 + 2 + 2 = 33 \text{ cm}$

Brush contact loss = voltage drop / brush set  $\times I_a = 2 \times 1000 = 2000 \text{ W}$

Brush frictional loss =  $9.81 \mu P_b A_{\text{ball}} v_C$

Let the coefficient of friction  $\mu = 0.25$  as it lies between 0.22 to 0.27 for carbon brushes.

Let the brush pressure  $P_b = 1215 \text{ kg/m}^2$  as it lies between 1000 to 1500  $\text{kg/m}^2$

$A_{\text{ball}}$  = Area of the brushes of all the brush arms

=  $t_b w_b n_b \times$  number of brush arms or number of poles as the number of brush arms number of poles for a lap winding  
 =  $2 \times 2.2 \times 10 \times 8 \times 10^{-4} = 0.0352 \text{ m}^2$

Brush frictional loss =  $9.81 \times 0.25 \times 1215 \times 0.0352 \times 15.1 = 1583.8 \text{ W}$

Therefore commutator losses (total) =  $2000 + 1583.8 = 3583.8 \text{ W}$

Temperature rise in degree centigrade

$$\theta = \frac{120 \times \text{watt loss} / \text{cm}^2 \text{ of the commutator dissipating surface } \pi D_C L_C}{1 + 0.1 v_C}$$

$$= \frac{120 \times 3583.8 / \pi \times 77 \times 33}{1 + 0.1 \times 15.1} = 21.46$$

### Example.2

A 20 Hp, 4 pole, 250V, 1000 rpm wave wound D.C. machine has the following design data. Diameter of the armature = 25 cm, number of slots = 41, number of coil sides / slot = 4, turns / coil = 2. Calculate the number of segments, outside width of one segment and mica, brush thickness, length of the commutator and brush contact loss.

Number of segments = number of active coils for a wave winding

i) Number of coil sides (total) =  $41 \times 4 = 164$

Number of coils =  $164 / 2 = 82$  as each coil will have 2 coil sides OR

ii) Since the coil is of 2 turns, each coil side will have 2 conductors and therefore the number of conductors per slot =  $4 \times 2 = 8$ .

Total number of conductors =  $41 \times 8 = 328$

Number of coils =  $\frac{\text{total number of conductors}}{2 \times \text{number of turns / coil}} = \frac{328}{2 \times 2} = 82$  OR

iii) Number of coils = number of slots  $\times$  number of coil sides / layer  
 =  $41 \times 2 = 82$

For a wave winding  $Y_C = \frac{C \pm 1}{p}$  must be an integer. With the number of coils calculated,  $Y_C = \frac{82 \pm 1}{2}$  is a fraction. Therefore a wave winding is not possible. However a wave winding can be made possible by considering one of the coils as dummy. Therefore number of active coils = 81 and number of commutator segments = 81.

Outside width of one segment and mica = Commutator segment pitch  

$$= \frac{\pi D_C}{\text{number of segments}}$$

$$= \frac{\pi \times 0.7 \times 25}{81}$$
 with the assumption that  $D_C = 0.7 D$   

$$= 0.68 \text{ cm}$$

Maximum thickness of the brush = 5 times the commutator segment pitch  

$$= 5 \times 0.68 = 3.4 \text{ cm}$$

Let the thickness of the brush  $t_b = 2.5 \text{ cm}$

Armature current  $I_a = \frac{H_p \times 746 / \eta}{V} = \frac{20 \times 746 / 0.9}{250} = 66.3 \text{ A}$

Cross-sectional area of the brush / spindle  $A_b = \frac{2 I_a}{A \delta_b} = \frac{2 \times 66.3}{2 \times 6} = 11.65 \text{ cm}^2$

Let the standard brush width  $W_b = 1.6 \text{ cm}$

Number of brushes / spindle  $n_b = \frac{A_b}{t_b W_b} = \frac{11.65}{2.5 \times 1.6} = 2.76$  and is not possible  

$$= 3 \text{ (say)}$$

Length of the commutator  $L_C = (1.6 + 0.5) 3 + 2 + 2 + 2 = 12.3 \text{ cm}$

Brush contact loss = Voltage drop / brush set  $\times I_a = 2.0 \times 66.3 = 132.6 \text{ W}$

### Example.3

A 600 kW, 6 pole lap connected D.C. generator with commutating poles running at 1200 rpm develops 230V on open circuit and 250V on full load. Find the diameter of the commutator, average volt / conductor, the number of commutator segments, length of commutator and brush contact loss. Take Armature diameter = 56 cm, number of armature conductors = 300, number of slots = 75, brush contact drop = 2.3 V, number of carbon brushes = 8 each 3.2 cm x 2.5 cm. The voltage between commutator segments should not exceed 15V.

[ Note :

1. The D.C. generator is a cumulative compound one, with 230V on open circuit and 250V on full load. Therefore while calculating the load current, 250V is to be considered.

2. The number of commutator segments or coils and hence the number of turns / coil must be so selected that the voltage per segment is not greater than 15V.
3. For a given voltage between segments, the volt / conductor goes on reducing as the number of turns / coil goes on increasing. Thus the volt / conductor is maximum when the turns / coil is minimum or turns / coil is one.
4. Volt / conductor = (voltage between segments) / (conductors /coil) or (2 x number of turns per coil)
5. There are 8 brushes / spindle of width 3.2 cm or 2.5 cm. ]

**UNIT -3 & 4**

**DESIGN OF TRANSFORMERS** (Single phase and three phase): Output equation for single phase and three phase transformers, choice of specific loadings, expression for volts/turn, determination of main dimensions of the core, types of windings and estimation of number of turns and conductor cross sectional area of Primary and secondary windings, estimation of no load current, expression for leakage reactance and voltage regulation. Design of tank and cooling tubes (round and rectangular). 12 Hours

**DESIGN OF TRANSFORMERS****Classification:**

Based on the number of phases: single or three phase  
 Based on the shape of the magnetic media: core or shell type  
 Based on the loading condition: power or distribution type

**Design features of power and distribution type transformers:****Power transformer**

1. Load on the transformer will be at or near the full load through out the period of operation. When the load is less, the transformer, which is in parallel with other transformers, may be put out of service.
2. Generally designed to achieve maximum efficiency at or near the full load. Therefore iron loss is made equal to full load copper loss by using a higher value of flux density. In other words, power transformers are generally designed for a higher value of flux density.
3. Necessity of voltage regulation does not arise. The voltage variation is obtained by the help of tap changers provided generally on the high voltage side. Generally Power transformers are deliberately designed for a higher value of leakage reactance, so that the short-circuit current, effect of mechanical force and hence the damage is less.

**Distribution transformer**

1. Load on the transformer does not remain constant but varies instant to instant over 24 hours a day
2. Generally designed for maximum efficiency at about half full load. In order that the all day efficiency is high, iron loss is made less by selecting a lesser value of flux density. In other words distribution transformers are generally designed for a lesser value of flux density.
3. Since the distributed transformers are located in the vicinity of the load, voltage regulation is an important factor. Generally the distribution transformers are not equipped with tap changers to maintain a constant voltage as it increases the cost, maintenance charges etc., Thus the distribution transformers are designed to have a low value of inherent regulation by keeping down the value of leakage reactance.

[ **Note** : Percentage regulation =  $\frac{I_1 R_p \cos\phi \pm I_1 X_p \sin\phi}{V_1} \times 100$  is less when the value of leakage

Reactance  $X_p$  is less, as the primary current  $I_1$  is fixed & resistance of the transformer  $R_p$  is almost negligible. Ideal value of regulation is zero. ]

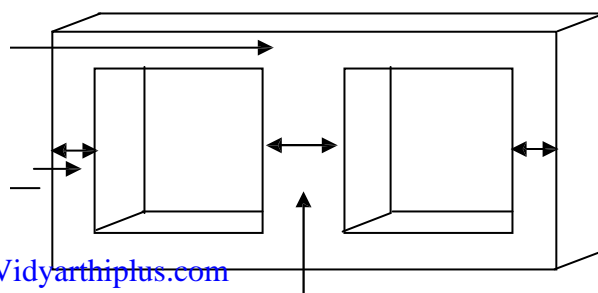
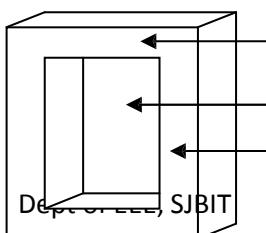
**Constructional Details of transformer**

Single-phase core type Transformer

Central leg  
Single-phase shell type transformer

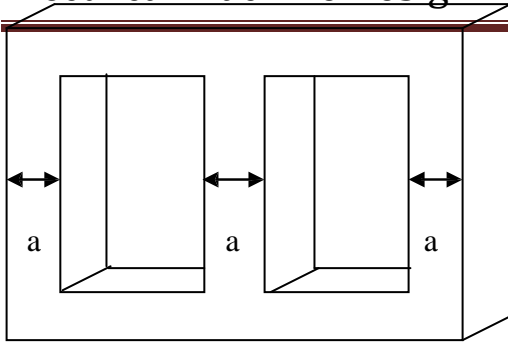

R

Y

B



3 phase, 3 leg or limb, core type Transformer

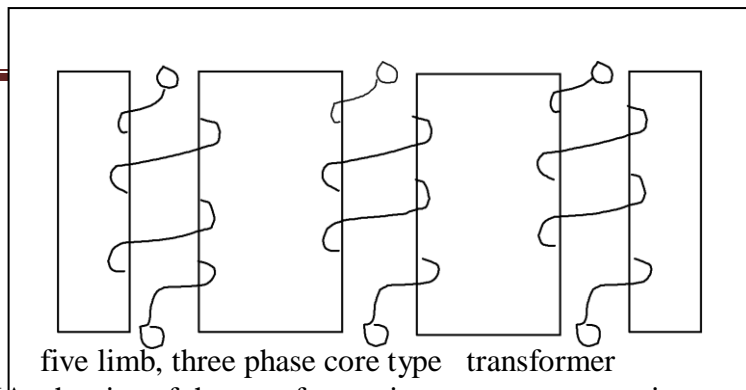

five limb, three phase core type transformer

[As the size of the transformer increases transportation difficulties arise because of rail or road gauges. To reduce the height of the transformer, generally a 5-limb core is used.]

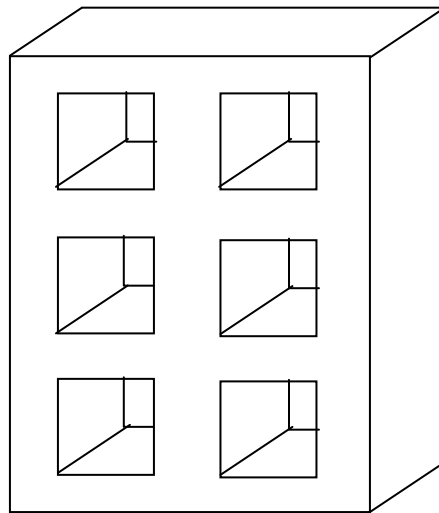

Three phase shell type transformer

**Winding arrangement**

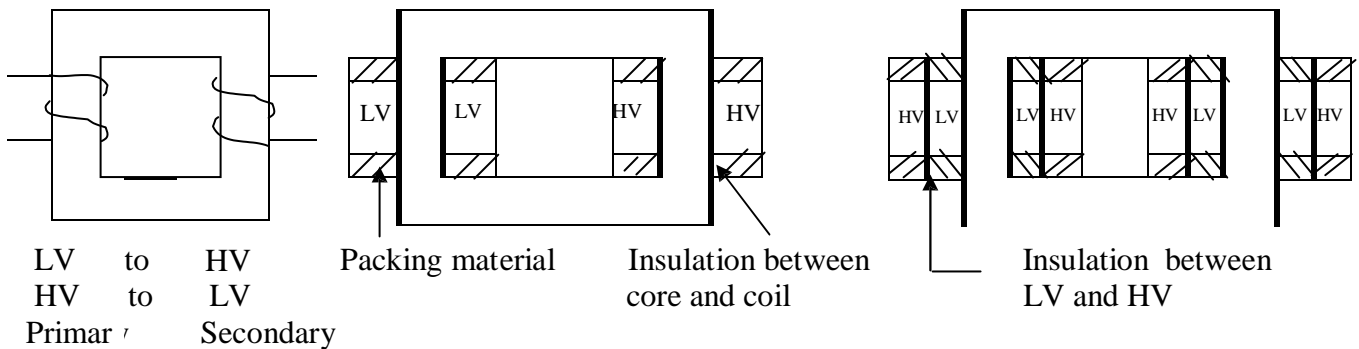

Unless otherwise specified, LV winding is always placed next to the core and HV winding over the LV winding in order to reduce the quantity of insulation used, avoid the possibility of breakdown of the space between the core and HV coil in case HV coil is provided next to the core and to control the leakage reactance. However in case of transformers where the voltage rating is less, LV and HV windings can be arranged in any manner.

**SPECIFICATION**

1. Output-kVA
2. Voltage- $V_1/V_2$  with or without tap changers and tapings
3. Frequency-f Hz
4. Number of phases – One or three
5. Rating – Continuous or short time
6. Cooling – Natural or forced
7. Type – Core or shell, power or distribution
8. Type of winding connection in case of 3 phase transformers – star-star, star-delta, delta-delta, delta-star with or without grounded neutral
9. Efficiency, per unit impedance, location (i.e., indoor, pole or platform mounting etc.), temperature rise etc.,

### SIZE OF THE TRANSFORMER

As the iron area of the leg  $A_i$  and the window area  $A_w$  = (height of the window  $H_w$  x Width of the window  $W_w$ ) increases the size of the transformer also increases. The size of the transformer increases as the output of the transformer increases.

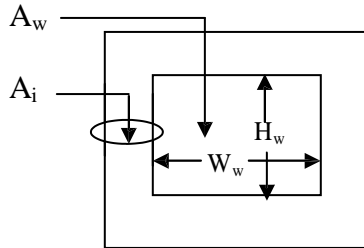

#### NOTE:

##### 1. Nomenclature:

$V_1$  – Applied primary voltage

$V_2$  – Secondary terminal voltage

$E_1, E_2$  – EMF induced in the primary and secondary windings per phase in case of 3 phase

$T_1, T_2$  – Number of primary and secondary turns per phase in case of 3 phase

$I_1, I_2$  – Primary and Secondary currents per phase in case of 3 phase

$a_1, a_2$  – Cross-sectional area of the primary and secondary winding conductors

$\delta$  - Current density in the transformer conductor. Assumed to be same for both LV and HV winding.

$\phi_m$  – Maximum value of the (mutual or useful) flux in weber =  $A_i B_m$

$B_m$  – Maximum value of the flux density =  $\phi_m / A_i$  tesla

$A_i$  – Net iron area of the core or leg or limb =  $K_i A_g$

$K_i$  – Iron or stacking factor = 0.9 approximately

$A_g$  – Gross area of the core

$$2. \quad \frac{V_1}{V_2} = \frac{E_1}{E_2} = \frac{T_1}{T_2} = \frac{I_2}{I_1}$$

- a. It is clear that  $V_1 I_1 = V_2 I_2$  or volt-ampere input is equal to volt-ampere output or kVA rating of both primary and secondary windings is same.
- b. It is clear that  $I_1 T_1 = I_2 T_2$  or primary mmf is equal to secondary mmf.
- c. It is clear that  $E_1 / T_1 = E_2 / T_2$  or volt/turn of both primary and secondary is same.

##### 2. Window space factor $K_w$

Window space factor is defined as the ratio of copper area in the window to the area of the window. That is

$$K_w = \frac{\text{Area of copper in the window } A_{cu}}{\text{Area of the window } A_w} < 1.0$$

For a given window area, as the voltage rating of the transformer increases, quantity of insulation in the window increases, area of copper reduces. Thus the window space factor reduces as the voltage increases. A value for  $K_w$  can be calculated by the following empirical formula.

10

$$K_w = \frac{\quad}{30 + kV_{hv}} \quad \text{where } kV_{hv} \text{ is the voltage of the high voltage winding expressed in kV.}$$

**OUTPUT EQUATIONS**

**a. Single phase core type transformer**

$$\text{Rating of the transformer in kVA} = V_1 I_1 \times 10^{-3} = E_1 I_1 \times 10^{-3} = 4.44 \phi_m f T_1 \times I_1 \times 10^{-3} \dots (1)$$

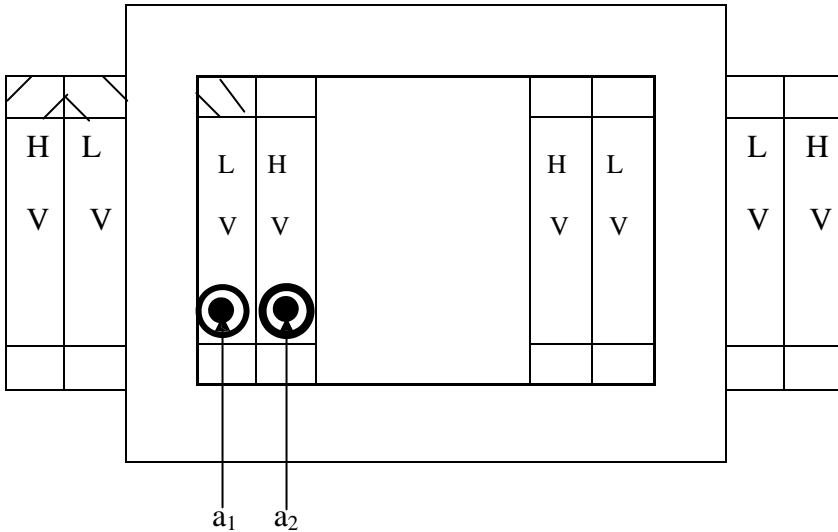

**Note:** Each leg carries half of the LV and HV turns

$$\text{Area of copper in the window } A_{cu} = a_1 T_1 + a_2 T_2 = \frac{I_1 T_1}{\delta} + \frac{I_2 T_2}{\delta} = \frac{2 I_1 T_1}{\delta} = A_w K_w$$

$$\text{Therefore } I_1 T_1 = \frac{A_w K_w \delta}{2} \dots (2)$$

$$\begin{aligned} \text{After substituting (2) in (1),} \quad \text{kVA} &= 4.44 A_i B_m f \times \frac{A_w K_w \delta}{2} \times 10^{-3} \\ &= 2.22 f \delta A_i B_m A_w K_w \times 10^{-3} \end{aligned}$$

**b. Single phase shell type transformer**

$$\begin{aligned} \text{Rating of the transformer in kVA} &= V_1 I_1 \times 10^{-3} = E_1 I_1 \times 10^{-3} \\ &= 4.44 \phi_m f T_1 \times I_1 \times 10^{-3} \dots (1) \end{aligned}$$

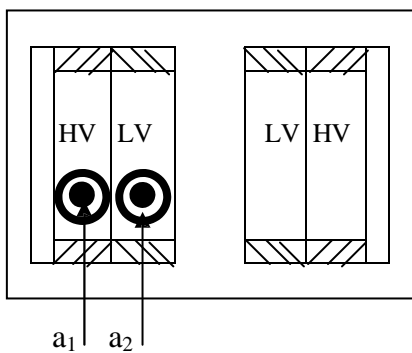

[ **Note :** Since there are two windows, it is sufficient to design one of the two windows as both the windows are symmetrical. Since the LV and HV windings are placed on the central leg, each window accommodates  $T_1$  and  $T_2$  turns of both primary and secondary windings.]

$$\text{Area of copper in the window } A_w = a_1 T_1 + a_2 T_2 = \frac{I_1 T_1}{\delta} + \frac{I_2 T_2}{\delta} = \frac{2 I_1 T_2}{\delta} = A_w K_w$$

Therefore  $I_1 T_1 = \frac{A_w K_w \delta}{2} \dots (2)$

After substituting (2) in (1)  $kVA = 4.44 A_i B_m f \times \frac{A_w K_w \delta}{2} \times 10^{-3}$   
 $= 2.22 f \delta A_i B_m A_w K_w \times 10^{-3}$

**c. Three phase core type transformer**

Rating of the transformer in kVA  $= V_1 I_1 \times 10^{-3} = E_1 I_1 \times 10^{-3} = 3 \times 4.44 \phi_m f T_1 \times I_1 \times 10^{-3} \dots (1)$

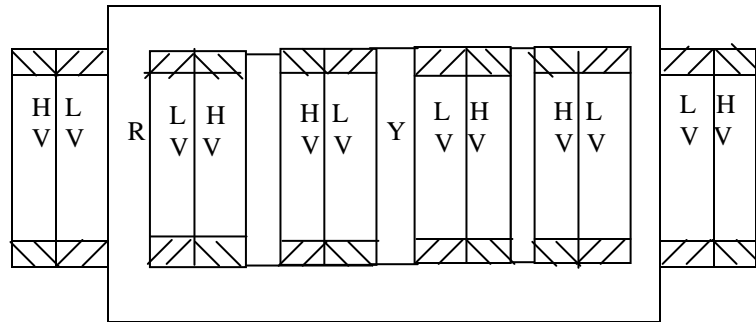

[**Note:** Since there are two windows, it is sufficient to design one of the two windows, as both the windows are symmetrical. Since each leg carries the LV & HV windings of one phase, each window carry the LV & HV windings of two phases]

Since each window carries the windings of two phases, area of copper in the window, say due to R & Y phases

$$A_{cu} = (a_1 T_1 + a_2 T_2) + (a_1 T_1 + a_2 T_2)$$

$$= 2(a_1 T_1 + a_2 T_2) = 2\left(\frac{I_1 T_1}{\delta} + \frac{I_2 T_2}{\delta}\right)$$

$$= 2 \times 2 \frac{I_1 T_1}{\delta} = A_w K_w$$

Therefore  $I_1 T_1 = \frac{A_w K_w \delta}{4} \dots (2)$

After substituting (2) in (1)

$kVA = 3 \times 4.44 A_i B_m f \times \frac{A_w K_w \delta}{2} \times 10^{-3} = 3.33 f \delta A_i B_m A_w K_w \times 10^{-3}$

**d. Three phase shell type transformer**

Rating of the transformer in kVA  $= 3 V_1 I_1 \times 10^{-3}$   
 $= 3 E_1 I_1 \times 10^{-3}$   
 $= 3 \times 4.44 \phi_m f T_1 \times I_1 \times 10^{-3} \dots (1)$

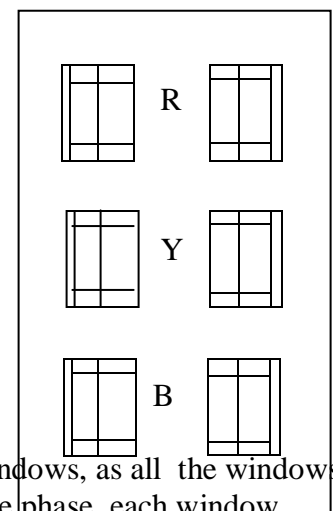

[ **Note:** Since there are six windows, it is sufficient to design one of the six windows, as all the windows are symmetrical. Since each central leg carries the LV and HV windings of one phase, each window carries windings of only one phase.]

Since each window carries LV and HV windings of only one phase,

$$\begin{aligned} \text{Area of copper in the window } A_w &= a_1 T_1 + a_2 T_2 = \frac{I_1 T_1}{\delta} + \frac{I_2 T_2}{\delta} \\ &= \frac{2 I_1 T_1}{\delta} = A_w K_w \end{aligned}$$

$$\text{Therefore } I_1 T_1 = \frac{A_w K_w \delta}{2} \quad \dots (2)$$

Substituting (2) in (1),

$$\begin{aligned} \text{kVA} &= 3 \times 4.44 A_i B_m f \times \frac{A_w K_w \delta}{2} \times 10^{-3} \\ &= 6.66 f \delta A_i B_m A_w K_w \times 10^{-3} \end{aligned}$$

### Usual values of current and Flux density:

The value of current density depends on the type of cooling-natural or forced. Upto 25000KVA natural cooling is adopted in practice. The current density lies between 2.0 and 3.2 A/mm<sup>2</sup> for natural cooling and between 5.3 and 6.4 A/mm<sup>2</sup> for forced cooling.

The flux density lies between 1.1 and 1.4 T in practice.

**Note :** To solve the output equation,  $\text{kVA} = 2.22 \text{ or } 3.33 \text{ or } 6.66 f \delta A_i B_m A_w K_w \times 10^{-3}$  having two unknowns  $A_i$  and  $A_w$ , volt per turn equation is considered.

### Volt / turn equation

$$\begin{aligned} \text{Rating of the transformer per phase kVA / ph} &= V_1 I_1 \times 10^{-3} = E_1 I_1 \times 10^{-3} \\ &= 4.44 \phi_m f T_1 I_1 \times 10^{-3} \end{aligned}$$

The term  $\phi_m$  is called the magnetic loading and  $I_1 T_1$  is called the electric loading. The required kVA can be obtained by selecting a higher value of  $\phi_m$  and a lesser of  $I_1 T_1$  or vice-versa.

As the magnetic loading increases, flux density and hence the core loss increases and the efficiency of operation decreases. Similarly as the electric loading increases, number of turns, resistance and hence the copper loss increases. This leads to reduced efficiency of operation. It is clear that there is no advantage by the selection of higher values of  $I_1 T_1$  or  $\phi_m$ . For an economical design they must be selected in certain proportion. Thus in practice

$$\frac{\phi_m}{I_1 T_1} = \text{a constant } K_t \text{ or } I_1 T_1 = \frac{\phi_m}{K_t} \quad \dots (2)$$

$$\text{Substituting (2) in (1), } \quad \text{kVA / ph} = 4.44 \phi_m f \frac{\phi_m}{K_t} \times 10^{-3} \quad \text{and} \quad \phi_m = \sqrt{\frac{K_t \times \text{kVA / ph}}{4.44 f \times 10^{-3}}}$$

Since the emf induced  $E_1 = 4.44 \phi_m f T_1$  is in  $T_1$  turns, voltage / turn

$$\begin{aligned} E_t = E_1 / T_1 &= 4.44 \phi_m f = 4.44 f \sqrt{\frac{K_t \times \text{kVA / ph}}{4.44 f \times 10^{-3}}} \\ &= \sqrt{4.44 f \times 10^3 \times K_t \times \text{kVA / ph}} = K_v \sqrt{\text{kVA}} \end{aligned}$$

Where  $K = 4.44 f \times 10^3 \times K_t$  is another constant and kVA is the rated output of the transformer. The constant K depends on the type of transformer-single or three phase, core or shell type, power or distribution type, type of factory organization etc.,

- Empirical values of K :**
- ( 1.0 to 1.2) for single phase shell type
  - 1.3 for three-phase shell type (power)
  - (0.75 to 0.85) for single phase core type
  - (0.6 to 0.7) for three phase core type (power)
  - 0.45 for three-phase core type (distribution)

**Core design**

$$\text{Net iron area of the leg or limb or core } A_i = \frac{\phi_m}{B_m} \text{ m}^2$$

For a given area  $A_i$ , different types of core section that are used in practice are circular, rectangular and square.

[Note: Choice of core section:

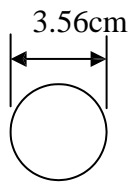

**Circular core**  
If the area is  $10\text{cm}^2$ , then the diameter of the core =  $3.56\text{cm}$  and the Circumference =  $\pi \times 3.56 = 11.2 \text{ cm}$

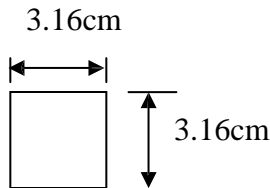

**Square core**  
for  $A_i = 10\text{cm}^2$ , side of the square =  $\sqrt{10} = 3.16 \text{ cm}$  and perimeter is  $4 \times 3.16 = 12.64\text{cm}$

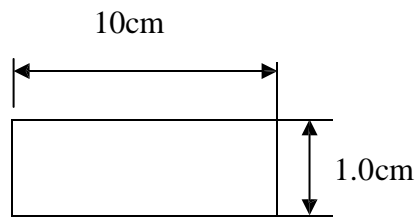

**Rectangular core**  
for  $A_i = 10\text{cm}^2$ , the perimeter =  $(10+1)2 = 22\text{cm}$  if the sides of the rectangular are assumed to be  $10\text{cm}$  and  $1.0\text{cm}$

It is clear that the rectangular core calls for more length of copper for the same number of turns as compared to circular core. Therefore circular core is preferable to rectangular or square core.

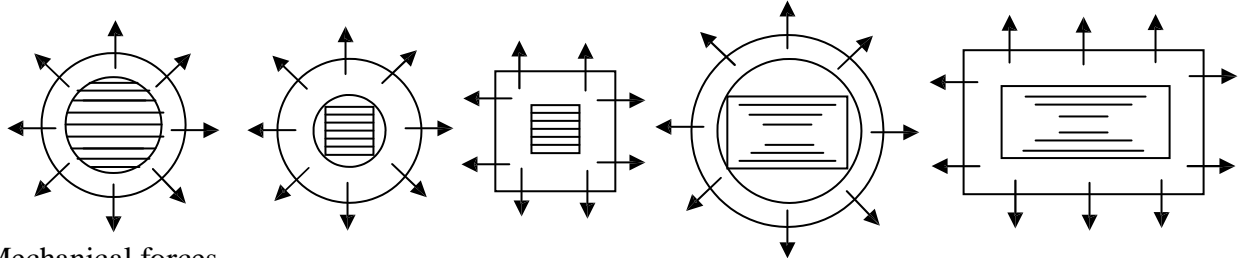

Mechanical forces  
Circular coil on a Circular core      Round coil on a square core      Square coil on a square core      Circular coil on a rectangular core      Rectangular coil on a rectangular core

Very high values of mechanical forces under short circuit conditions tries to deform the shape of the square or rectangular coil (the mechanical forces try to deform to a circular shape) and hence damage the coil and insulation. Since this is not so in case of circular coils, circular coils are preferable to square or rectangular coils.

Thus a circular core and a circular coil is preferable. Since the core has to be of laminated type, circular core is not practicable as it calls for more number of different size laminations and poses the problem of securing them together in position. However, a circular core can be approximated to a stepped core having infinite number of steps. Minimum number of steps one and the number of steps in practice is limited to a definite number. Whenever a stepped core is employed a circular coil is used.

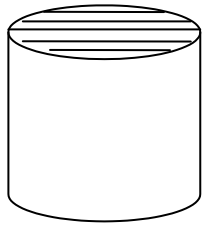

Laminated circular core

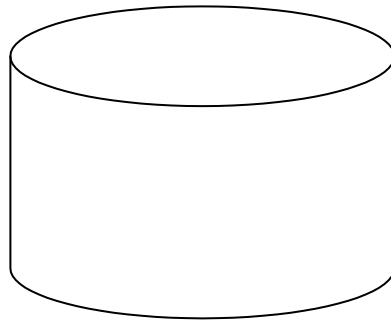

Stepped core approximated to a circular core

**Leg or limb section details: -**

The different types of leg sections used are rectangular, square and stepped.

**1. Rectangular core (with a rectangular coil)**

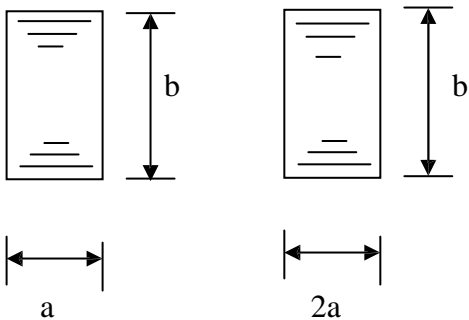

Leg of a core type Transformer

Central leg of a shell type transformer

- $a$  = width of the stamping or leg
- $b$  = gross thickness of the assembled core or width of the transformer
- $A_i$  = net iron area of the leg or limb or core  
=  $a \times K_i \times b$  for a core type transformer
- $K_i$  = iron factor or stacking factor
- $2a$  = width of the central leg
- $b$  = width of the transformer
- $A_i = 2a \times K_i \times b$  for a shell type transformer

**2. (a) Square core (with a square coil)**

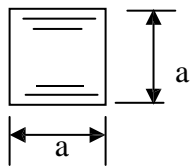

- $a$  = width of the leg
- $a$  = width of the transformer
- $A_i = K_i a^2$  for a core transformer
- $2a$  = width of the central leg
- $2a$  = width of the transformer
- $A_i = K_i (2a)^2$  for a shell type transformer

**(b) Square core (with a circular coil)**

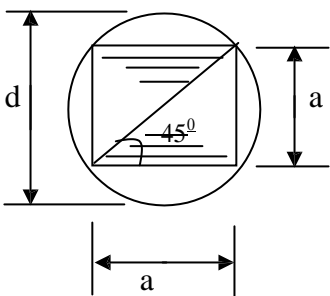

- $a$  = width of the stamping or leg
- =  $d \sin 45$  or  $d \cos 45$
- =  $0.71d$  where  $d$  is the diameter of the circumscribing circle
- $A_i = K_i a^2 = K_i (0.71d)^2$
- =  $0.9 \times 0.5d^2$  for 10% insulation or  $K_i = 0.9$
- =  $0.45d^2$

Area of the circumscribing circle  $A_c = \pi d^2 / 4 = 0.785d^2$

Therefore  $A_i = 0.45d^2 = 0.573$

$$A_c = 0.785d^2$$

It is clear that  $A_i$  is only 57.3% of  $A_c$ . Rest of the area 42.7% of  $A_c$  is not being utilized usefully. In order to utilize the area usefully, more number of steps is used. This leads to 2 stepped, 3 stepped etc core.

**3. Cruciform or 2-stepped core:**

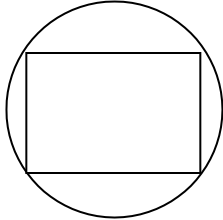

$a$  = width of the largest stamping  
 $b$  = width of the smallest stamping  
 Gross area of the core  $A_g = ab + 2b(a-b)/2 = 2ab - b^2$   
 Since  $a = d \cos\theta$  and  $b = d \sin\theta$   
 $A_g = 2d^2 \cos\theta \sin\theta - d^2 \sin^2\theta = d^2(\sin 2\theta - \sin^2\theta)$

In order that  $A_g$  is maximum,  $\frac{dA_g}{d\theta} = d^2 (2 \cos 2\theta - 2 \sin\theta \cos\theta)$   
 $= d^2 (2 \cos 2\theta - \sin 2\theta) = 0$   
 That is,  $2 \cos 2\theta - \sin 2\theta = 0$

or  $\frac{\sin 2\theta}{\cos 2\theta} = 2$  or  $\tan 2\theta = 2$  or  $\theta = 31.7^\circ$

Thus  $A_g$  is maximum when  $\theta = 31.7^\circ$ . With  $\theta = 31.7^\circ$ ,  $a = d \cos 31.7 = 0.85d$  and  $b = d \sin 31.7 = 0.53d$   
 $A_g = 2 \times 0.85d \times 0.53d - (0.53d)^2 = 0.62d^2$   
 $A_i = K_i A_g = 0.9 \times 0.62d^2 = 0.56d^2$

and  $\frac{A_i}{A_g} = \frac{0.56d^2}{0.785d^2} = 0.71$

It is clear that addition of one step to a square core, enhances the utilization of more space of the circumscribing circle area.

**4. Three stepped core:**

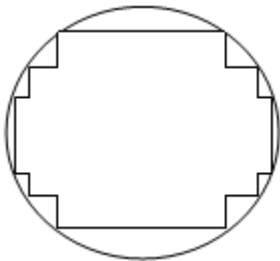

Width of the largest stamping  $a = 0.9d$   
 Width of the middle stamping  $b = 0.7d$   
 Width of the smallest stamping  $c = 0.42d$   
 $A_i = 0.6d^2$

**5. Four stepped core:**

Width of the largest stamping  $a = 0.93d$   
 $A_i = 0.62d^2$

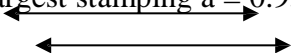
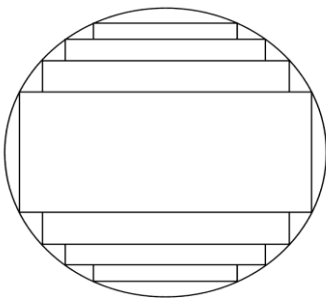

**Note :** As the number of steps increases, the diameter of the circumscribing circle reduces. Though the cost of the core increases, cost of copper and size of the coil or transformer reduces.

**Yoke section details:**

The purpose of the yoke is to connect the legs providing a least reluctance path. In order to limit the iron loss in the yoke, operating flux density is reduced by increasing the yoke area. Generally yoke area is made 20% more than the leg area..

**Note:** 1. Whenever the yoke area is different from the leg area, yoke can considered to be of rectangular type for convenience.

2. In general height of the yoke  $H_y$  can be taken as (1.0 to 1.5)  $a$ . When there is no data about the yoke area, consider  $H_y = a$ .

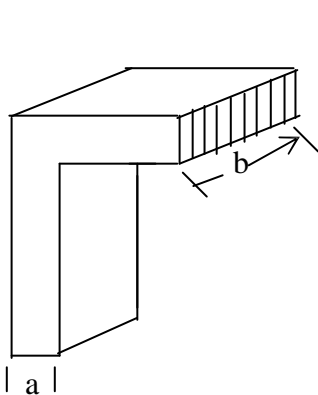

Rectangular leg and yoke

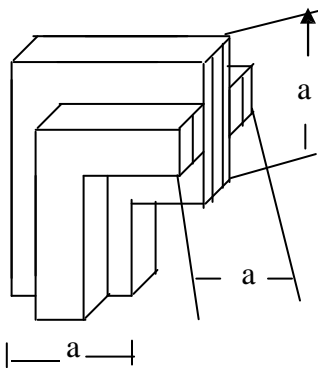

Cruciform leg and yoke

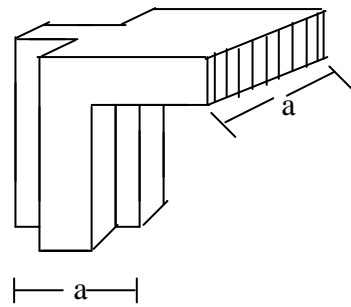

Rectangular yoke and Cruciform leg

The different types of yoke sections used are square, rectangular and stepped.

**Window area and core proportion**

$$\text{Area of the window } A_w = \frac{\text{kVA}}{(2.22 \text{ or } 3.33 \text{ or } 6.66) f \delta A_i B_m K_w \times 10^{-3}} \text{ m}^2$$

If  $H_w$  = height of the window,  $W_w$  = width of the window, then  $A_w = H_w W_w$

In order to limit the leakage reactance of the transformer,  $H_w$  is made more than  $W_w$ . In practice  $H_w / W_w$  lies between 2.5 and 3.5.

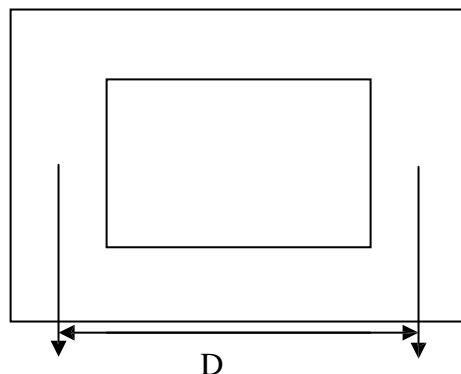
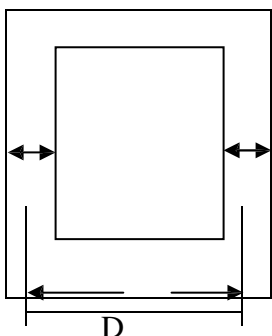

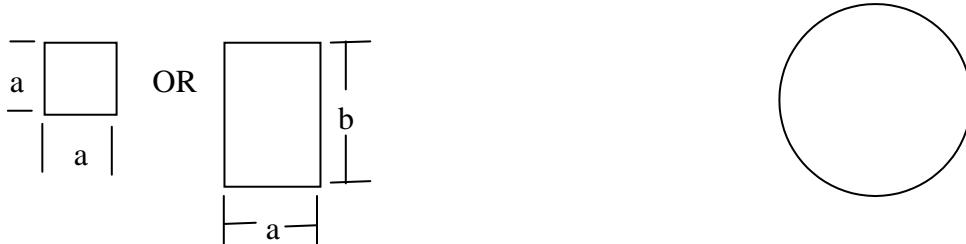

Square or rectangular core with square or rectangular coil      Stepped leg (Uses only circular coil)

**Core type transformer**

- Note:**
1. D-distance between the two core or leg central lines
  2. Width  $W_w$  is measured from one edge of the leg to the other of the adjacent leg in case of square or rectangular core with square or rectangular coil and between the two circumscribing circles of adjacent legs in case of stepped legs.
  3. Depth or width of the core type transformer = b in case of rectangular core  
= a in case of square or stepped core

Overall length =  $(W_w + 2a)$  or  $(D+a)$  in case of single phase core type transformer with square or rectangular core  
 =  $(W_w+d+a)$  or  $(D+a)$  in case of single phase core type transformer with a Stepped leg  
 =  $(2W_w + 2d + a)$  or  $(2D+a)$  in case of three phase core type transformer with a stepped leg. No square or rectangular leg is used for high capacity three phase transformers.

Overall height =  $(H_w + 2H_y)$  for all core type transformers.

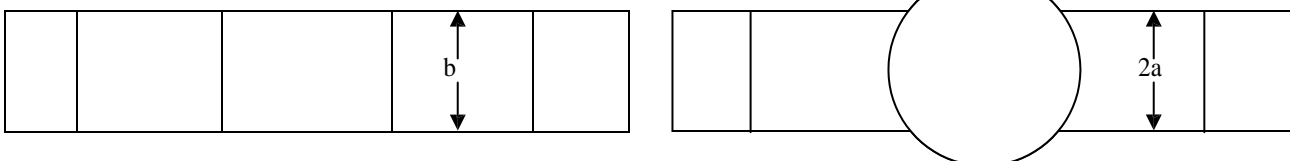
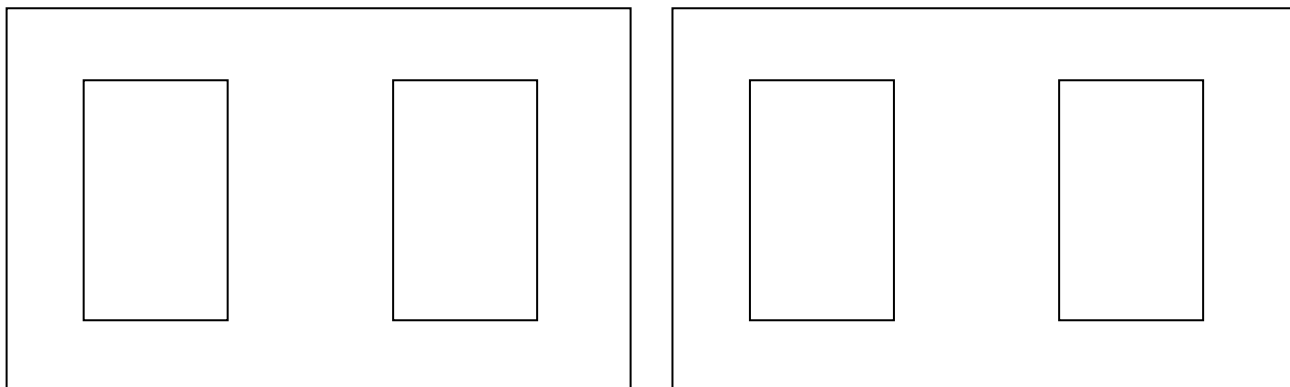

Shell type transformer with square or rectangular core

Shell type transformer with a stepped central leg (Calls for a rectangular outer leg)

Depth or width of the Shell type transformer = b in case of rectangular central leg  
 = 2a in case of stepped central leg

Overall length =  $(2W_w + 4a)$  in case of a shell type transformer with rectangular or square central leg  
 =  $(d + 2W_w + 2a)$  in case of shell type transformer with central stepped leg

Overall height =  $(H_w + 2H_y)$  in case of a single phase shell type transformer  
 =  $3(H_w + 2H_y)$  in case of a three phase shell type transformer

**Winding details:**

Since the applied voltage  $V_1$  is approximately equal to the voltage induced  $E_1 = 4.44 \phi_m f T_1 = E_t T_1$

Number of primary turns (or turns / phase)  $T_1 = V_1 / E_t$  in case of single phase transformers  
 =  $V_{1ph} / E_t$  in case of 3 phase transformers

Number of secondary turns (or turns / phase)  $T_2 = V_2 / E_t$  in case of single phase transformers  
 =  $V_{2ph} / E_t$  in case of 3 phase transformers

Primary current (or current/phase)  $I_1 = kVA \times 10^3 / V_1$  in case of single phase transformers  
 =  $kVA \times 10^3 / 3V_{1ph}$  in case of 3 phase transformers

Cross-sectional area of primary winding conductor  $a_1 = I_1 / \delta \text{ mm}^2$

Secondary current (or current / phase)  $I_2 = kVA \times 10^3 / V_2$  in case of single phase transformers  
 =  $kVA \times 10^3 / 3V_{2ph}$  in case of 3 phase transformers

Cross-sectional area of secondary winding conductor  $a_2 = I_2 / \delta \text{ mm}^2$

Knowing the number of turns and cross-sectional area of the primary and secondary winding conductors, number of turns/layer in a window height of  $H_w$  and number of layers in a window width of  $W_w$  can be found out.

**No-load current of a transformer**

The no-load current  $I_0$  is the vectorial sum of the magnetizing current  $I_m$  and core loss or working component current  $I_c$ . [Function of  $I_m$  is to produce flux  $\phi_m$  in the magnetic circuit and the function of  $I_c$  is to satisfy the no load losses of the transformer]. Thus,

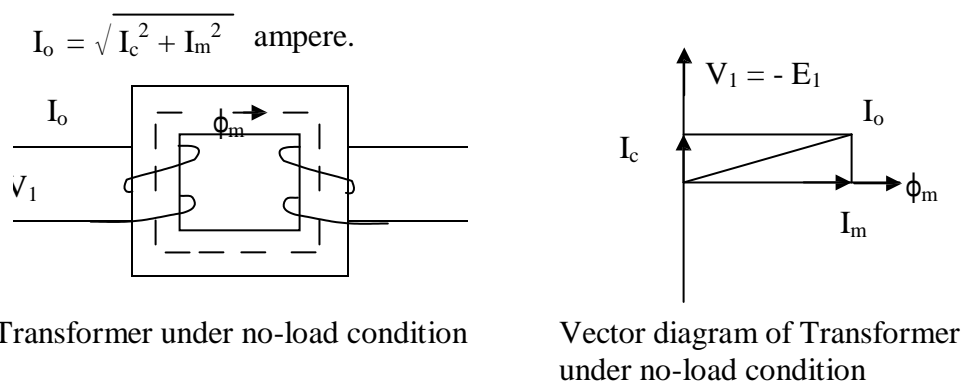

No load input to the transformer =  $V_1 I_0 \cos \phi_0 = V_1 I_c =$  No load losses as the output is zero and input = output + losses.

Since the copper loss under no load condition is almost negligible, the no load losses can entirely be taken as due to core loss only. Thus the core loss component of the no load current

$$I_c = \frac{\text{core loss}}{V_1} \text{ for single phase transformers}$$

$$= \frac{\text{core loss / phase}}{V_{1\text{ph}}} \quad \text{for 3 phase transformers.}$$

$$\text{RMS value of magnetizing current } I_m = \frac{\text{Magnetizing ampere turns (Max value)}}{\sqrt{2} T_1}$$

with the assumption that the magnetizing current is sinusoidal (which is not true in practice)

The magnetic circuit of a transformer consists of both iron and air path. The iron path is due to legs and yokes and air path is due to the unavoidable joints created by the core composed of different shaped stampings. If all the joints are assumed to be equivalent to an air gap of  $l_g$ , then the total ampere turns for the transformer magnetic circuit is equal to  $AT_{\text{for iron}} + 800,000l_g B_m$ . Therefore,

$$I_m = \frac{AT_{\text{for iron}} + 800,000l_g B_m}{\sqrt{2} T_1}$$

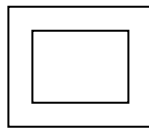

One piece stamping  
Impracticable pre-formed

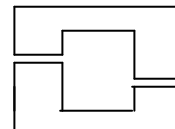

Two piece stamping  
(called for the use of coils on the legs)

**Note:**

1. In case of a transformer of normal design, the no load current will generally be less than about 2% of the full load current.
2. No load power factor  $\text{Cos}\phi_0 = I_c/I_0$  and will be around 0.2.
3. Transformer copper losses:
  - a) The primary copper loss at no load is negligible as  $I_0$  is very less.
  - b) The secondary copper loss is zero at no load, as no current flows in the secondary winding at no load.
4. Core or iron loss:
 

Total core loss = core loss in legs + core loss in yokes.

The core loss can be estimated at design stage by referring to graph of core loss/kg versus flux density.

$$\begin{aligned} \text{Core loss in leg} &= \text{loss/kg in leg} \times \text{weight of leg in kg} \\ &= \text{loss / kg in leg} \times \text{volume of the leg } (A_l H_w) \times \text{density of steel or iron used} \end{aligned}$$

$$\text{Core loss in yoke} = \text{loss/kg in Yoke} \times \text{volume of yoke } (A_y \times \text{mean length of the yoke}) \times \text{density of iron used}$$

The density of iron or steel used for the transformer core lies between 7.55 to 7.8 grams/cc.

**RESISTANCE AND REACTANCE OF TRANSFORMER**

**Resistance:**

$$\text{Resistance of the transformer referred to primary / phase } R_p = r_p + r_s' = r_p + r_s \left[ \frac{T_1}{T_2} \right] \quad \frac{T_p}{T_s} \quad \text{or} \quad \frac{V_1^2}{V_2^2}$$

$$\text{Resistant of the primary winding/phase } r_p = \frac{(\rho L_{mt}) T_p}{a_1} \text{ ohm}$$

$$\text{Resistivity of copper at } 60^{\circ}\text{C} \quad \rho = 2.1 \times 10^{-6} \text{ ohm-cm or } 2.1 \times 10^{-8} \text{ ohm-m or } 0.021 \text{ ohm-m/mm}^2$$

$$\text{Mean length of turn of the primary winding } L_{mt P} = \pi \times \text{mean diameter of the primary winding}$$

Number of primary turns / phase  $T_1$  or  $T_p = V_{1ph} / E_t$

Resistance of the secondary winding / phase  $r_s = \frac{\rho L_{mt}}{a_2} T_s$

Mean length of turn of the secondary winding  $L_{mt s} = \pi \times \text{mean diameter of the secondary winding}$

Number of secondary turns / phase  $T_2$  or  $T_s = V_{2ph} / E_t$

Similarly resistance of the transformer referred to secondary / phase  $R_s = r_p' + r_s = r_p \left[ \frac{T_s}{T_p} \right]^2 + r_s$

### Reactance:

[Note: 1. Useful flux: It is the flux that links with both primary and secondary windings and is responsible in transferring the energy Electro-magnetically from primary to secondary side. The path of the useful flux is in the magnetic core.

2. Leakage flux: It is the flux that links only with the primary or secondary winding and is responsible in imparting inductance to the windings. The path of the leakage flux depends on the geometrical configuration of the coils and the neighboring iron masses.

3. Reactance:

- Leakage reactance =  $2\pi f \times \text{inductance} = 2\pi f \times \text{Flux linkage} / \text{current}$
- Flux linkage = flux  $\times$  number of turns
- Flux = (mmf or AT) / Reluctance = AT  $\times$  permeance  $\wedge$
- Permeance  $\wedge = 1 / \text{Reluctance} = a\mu_0\mu_r / l$  where

$a$  = area over which the flux is established

$l$  = length of the flux path

If  $x_p$  and  $x_s$  are the leakage reactances of the primary and secondary windings, then the total leakage reactance of the transformer referred to primary winding  $X_p = x_p + x_s' = x_p + x_s (T_p/T_s)^2$ .

Similarly the leakage reactance of the transformer referred to secondary winding

$$X_s = x_p' + x_s = x_p (T_s / T_p)^2 + x_s .$$

Estimation of the leakage flux or reactance is always difficult, on account of the complex geometry of the leakage flux path and great accuracy is unobtainable. A number of assumptions are to be made to get a usable approximate expression. Validity or the accuracy of the expression is checked against test data.

### Expression for the leakage reactance of a core type transformer with concentric LV and HV coils of equal height or length:

Assumptions considered for the derivation:

- Effect of magnetizing current is neglected.
- Reluctance and effect of saturation of iron is neglected.
- All the mmf is assumed to be used to overcome the reluctance of coil height
- Leakage flux distribution in coil and in the space between the LV and HV coils is assumed to be parallel to the leg axis.

Let,

$b_p$  and  $b_s$  = Radial depth of primary and secondary windings

$T_p$  and  $T_s$  = Number of primary and secondary turns per phase for 3 phase

$I_p$  and  $I_s$  = Primary and secondary currents per phase for 3 phase

$L_{mt P}$   $L_{mt S}$  = Mean length of turn of primary or secondary windings respectively

$L_{mt}$  = Mean length of primary and secondary windings considered together

$L_0$  = Circumference of the insulation portion or duct or both between LV and HV coils

$L_c$  = Axial height or length of the both LV and HV coils

The total flux linkage of the primary or secondary winding is due to

- Leakage flux inside the primary or secondary winding and
- Leakage flux in between the LV and HV coils

To determine the flux linkage due to the flux inside the coil, consider an elemental strip  $dx$  at a distance 'x' from the edge of the LV winding (say primary winding). Then the flux linkage of the primary winding, due to the flux  $\phi_x$  in the strip.

$$\begin{aligned}\Psi_x &= \phi_x \times \text{number of turns linked by } \phi_x \\ &= \text{ampere turns producing } \phi_x \times \text{permeance of the strip} \times \text{number of turns linked by } \phi_x \\ &= I_p \frac{T_p x}{b_p} \times \frac{L_{mt p}}{L_c} dx \mu_0 \times \frac{T_p x}{b_p}\end{aligned}$$

Considering the mean length of the strip is approximately equal to  $L_{mt p}$ .

Therefore, the total flux linkage due to the flux inside the coil

$$\Psi = \int_0^{b_p} I_p T_p^2 \frac{\mu_0 L_{mt p}}{b_p^2 L_c} x^2 dx = I_p T_p^2 \mu_0 \frac{L_{mt p}}{L_c} x \frac{b_p}{3}$$

If one half of the flux  $\phi_0$  in between the LV and HV windings is assumed to be linking with each windings, then the flux linkage of the primary winding due to half of the flux  $\phi_0$  in between LV and HV windings,

$$\begin{aligned}\Psi_0 &= \frac{1}{2} \phi_0 \times \text{number of turns linked by } \phi_0 \\ &= \text{ampere turns producing } \phi_0 \times \text{permeance of the duct} \times \text{number of turns linked by flux } \phi_0 . \\ &= \frac{1}{2} I_p T_p \times \frac{L_0 \mu_0}{L_c} \times T_p\end{aligned}$$

$$\begin{aligned}\text{Therefore total flux linkage of the primary winding} &= \Psi + \Psi_0 = I_p T_p^2 \mu_0 \left( \frac{L_{mt p} b_p}{L_c} + \frac{L_0 a}{2} \right) \\ &= I_p T_p^2 \mu_0 \frac{L_{mt p}}{L_c} \left( \frac{b_p}{3} + \frac{a}{2} \right) \text{ with the assumption that } L_{mt p} \approx L_0\end{aligned}$$

Therefore leakage reactance of the primary / ph

$$\begin{aligned}x_p &= 2\pi f \times \frac{\text{flux linkage}}{\text{Current}} \\ &= \frac{2\pi f \times I_p T_p^2 \mu_0 L_{mt p} \left( \frac{b_p}{3} + \frac{a}{2} \right)}{I_p} \\ &= 2\pi f T_p^2 \mu_0 \frac{L_{mt s}}{L_c} \left( \frac{b_p}{3} + \frac{a}{2} \right) \text{ ohm}\end{aligned}$$

Similarly leakage reactance of the secondary winding / ph

$$x_s = 2\pi f T_s^2 \mu_0 \frac{L_{mt\ s}}{L_c} \left( \frac{b_s}{3} + \frac{a}{2} \right) \text{ ohm}$$

Therefore leakage reactance of the transformer referred to primary winding per phase

$$\begin{aligned} X_p &= x_p + x'_s = x_p + x_s \left( \frac{T_p}{T_s} \right)^2 \\ &= 2\pi f T_p^2 \frac{\mu_0}{L_c} \left[ L_{mt\ p} \left( \frac{b_p}{3} + \frac{a}{2} \right) + L_{mt\ s} \left( \frac{b_s}{3} + \frac{a}{2} \right) \right] \\ &= 2\pi f T_p^2 \mu_0 \frac{L_{mt}}{L_c} \left[ \frac{b_p}{3} + \frac{b_s}{3} + a \right] \text{ ohm} \end{aligned}$$

### DESIGN OF TANK AND TUBES

Because of the losses in the transformer core and coil, the temperature of the core and coil increases. In small capacity transformers the surrounding air will be in a position to cool the transformer effectively and keeps the temperature rise well within the permissible limits. As the capacity of the transformer increases, the losses and the temperature rise increases. In order to keep the temperature rise within limits, air may have to be blown over the transformer. This is not advisable as the atmospheric air containing moisture, oil particles etc., may affect the insulation. To overcome the problem of atmospheric hazards, the transformer is placed in a steel tank filled with oil. The oil conducts the heat from core and coil to the tank walls. From the tank walls the heat goes dissipated to surrounding atmosphere due to radiation and convection. Further as the capacity of the transformer increases, the increased losses demands a higher dissipating area of the tank or a bigger sized tank. This calls for more space, more volume of oil and increases the cost and transportation problems. To overcome these difficulties, the dissipating area is to be increased by artificial means without increasing the size of the tank. The dissipating area can be increased by

1. fitting fins to the tank walls
2. using corrugated tank
3. fitting tubes to the tank and
4. using auxiliary radiator tanks

Since the fins are not effective in dissipating heat and corrugated tank involves constructional difficulties, they are not much used now a days. The tank with tubes are much used in practice. Tubes in more number of rows are to be avoided as the screening of the tank and tube surfaces decreases the dissipation. Hence, when more number of tubes are to be provided, a radiator attached with the tank is considered. For much larger sizes forced cooling is adopted.







tank and ambient air temperature and  $6.5W$  goes dissipated by convection /  $m^2$  of plain surface / degree centigrade difference in temperature between tank wall and ambient air. Thus a total of  $12.5W/m^2/^\circ C$  goes dissipated to the surrounding. If  $\theta$  is the temperature rise, then at final steady temperature condition, losses responsible for temperature rise is losses dissipated or transformer losses =  $12.5 S_t \theta$

### **Number and dimensions of tubes**

If the temperature rise of the tank wall is beyond a permissible value of about  $50^\circ C$ , then cooling tubes are to be added to reduce the temperature rise. Tubes can be arranged on all the sides in one or more number of rows. As number of rows increases, the dissipation will not proportionally increase. Hence the number of rows of tubes are to be limited. Generally the number of rows in practice will be less than four.

With the tubes connected to the tank, dissipation due to radiation from a part of the tank surface screened by the tubes is zero. However if the radiating surface of the tube, dissipating the heat is assumed to be equal to the screened surface of the tank, then tubes can assumed to be radiating no heat. Thus the full tank surface can assumed to be dissipating the heat due to both radiation and convection & can be taken as  $12.5 S_t \theta$  watts.

Because the oil when get heated up moves up and cold oil down, circulation of oil in the tubes will be more. Obviously, this circulation of oil increases the heat dissipation. Because of this syphoning action, it has been found that the convection from the tubes increase by about 35 to 40%. Thus if the improvement is by 35%, then the dissipation in watts from all the tubes of area  $A_t = 1.35 \times 6.5 A_t \theta = 8.78 A_t \theta$ .

Thus in case of a tank with tubes, at final steady temperature rise condition, Losses =  $12.5 S_t \theta + 8.78 A_t \theta$

Round, rectangular or elliptical shaped tubes can be used. The mean length or height of the tubes is generally taken as about 90% of tank height.

In case of round tubes, 5 cm diameter tubes spaced at about 7.5cm (from centre to centre) are used. If  $d_t$  is the diameter of the tube, then dissipating area of each tube  $a_t = \pi d_t \times 0.9 H_t$ . if  $n_t$  is the number of tubes, then  $A_t = a_t n_t$ .

Now a days rectangular tubes of different size spaced at convenient distances are being much used, as it provides a greater cooling surface for a smaller volume of oil. This is true in case of elliptical tubes also.

The tubes can be arranged in any convenient way ensuring mechanical strength and aesthetic view.

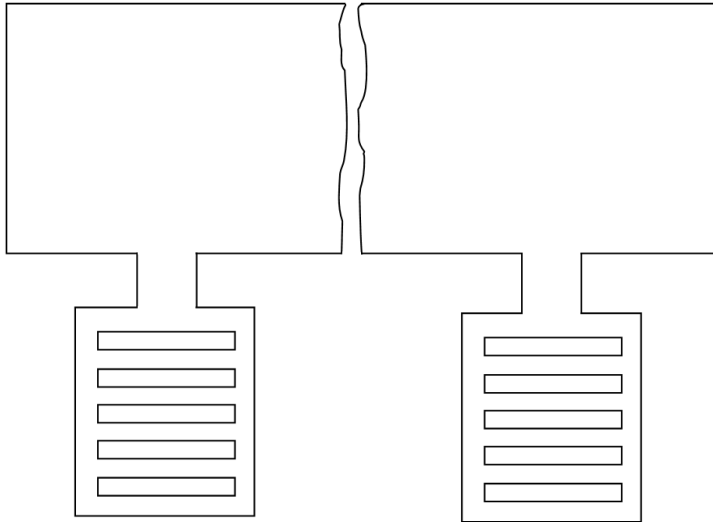

**Different ways of tube arrangement (round)**

**Different ways of tube arrangement (rectangular)**

\*\*\*\*\*  
\*\*\*\*

**Problems on transformer main dimensions and windings**

1. Determine the main dimensions of the core and window for a 500 kVA, 6600/400V, 50Hz, Single phase core type, oil immersed, self cooled transformer. Assume: Flux density = 1.2 T, Current density = 2.75 A/mm<sup>2</sup>, Window space factor = 0.32, Volt / turn = 16.8, type of core: Cruciform, height of the window = 3 times window width. Also calculate the number of turns and cross-sectional area of the conductors used for the primary and secondary windings.

Since volt / turn  $E_t = 4.44 \phi_m f$

Main or

Mutual flux  $\phi = \frac{E_t}{4.44 f}$

$$= \frac{16.8}{4.44 \times 50}$$

$$= \frac{0.076}{W_b}$$

$$\text{Net iron area of the leg or limb } A_i = \frac{\phi_m}{1.2} = 0.0633 \text{ m}^2$$

=

$$B_m$$

Since for a cruciform core  $A_i = 0.56d^2$ ,

$$\text{diameter of the circumscribing circle } d = \sqrt{\frac{A_i}{0.56}} = \sqrt{\frac{0.0633}{0.56}} = 0.34 \text{ m}$$

$$\text{width of the largest stamping } a = 0.85d = 0.85 \times 0.34 = 0.29 \text{ m}$$

$$\text{width of the transformer } = a = 0.29 \text{ m}$$

$$\text{width of the smallest stamping } b = 0.53d = 0.53 \times 0.34 = 0.18 \text{ m}$$

$$\text{Height of the yoke } H_y = (1.0 \text{ to } 1.5) a = a \text{ (say)} = 0.29 \text{ m}$$

$$kVA = 2.22 f \delta A_i B_m A_w K_w \times 10^{-3}$$

$$500 = 2.22 \times 50 \times 2.75 \times 10^6 \times 0.0633 \times 1.2 \times A_w \times 0.32 \times 10^{-3}$$

$$\text{Area of the window } A_w = 0.067 \text{ m}^2$$

$$\text{Since } H_w = 3 W_w, A_w = H_w W_w = 3W_w^2 = 0.067$$

$$\text{Therefore, width of the window } W_w = \sqrt{\frac{0.067}{3}} = 0.15 \text{ m}$$

$$\text{and height of the window } H_w = 3 \times 0.15 = 0.45 \text{ m}$$

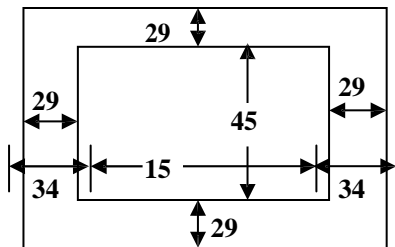

Details of the core

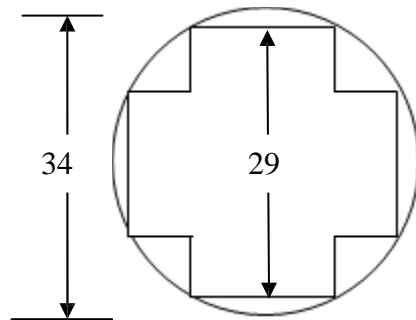

Leg and yoke section (with the assumption Yoke is also of cruciform type)

All dimensions are in cm

$$\text{Overall length of the transformer} = W_w + d + a = 0.15 + 0.34 + 0.29 = 0.78 \text{ m}$$

$$\text{Overall height of the transformer} = H_w + 2H_y \text{ or } 2a = 0.45 + 2 \times 0.29 = 1.03 \text{ m}$$

$$\text{Width or depth of the transformer} = a = 0.29 \text{ m}$$

$$\text{Number of primary turns } T_1 = \frac{V_1}{E_t} = \frac{6600}{16.8} \approx 393$$

=

$$E_t$$

Number of secondary turns  $T_2 = \frac{V_2}{E_t} = \frac{400}{16.8} \approx 24$

Primary current  $I_1 = \frac{\text{kVA} \times 10^3}{V_1} = \frac{500 \times 10^3}{6600} = 75.75 \text{ A}$

Cross-sectional area of the primary winding conductor  $a_1 = \frac{I_1}{\delta} = \frac{75.75}{2.75} = 27.55 \text{ mm}^2$

Secondary current  $I_2 = \frac{\text{kVA} \times 10^3}{V_2} = \frac{500 \times 10^3}{400} = 1250 \text{ A}$

Cross-sectional area of the secondary winding conductor  $a_2 = \frac{I_2}{\delta} = \frac{1250}{2.75} = 454.5 \text{ mm}^2$

2. Determine the main dimensions of the 3 limb core (i.e., 3 phase, 3 leg core type transformer), the number of turns and cross-sectional area of the conductors of a 350 kVA, 11000/ 3300 V, star / delta, 3 phase, 50 Hz transformer. Assume: Volt / turn = 11, maximum flux density = 1.25 T. Net cross-section of core =  $0.6 \text{ d}^2$ , window space factor = 0.27, window proportion = 3 : 1, current density =  $250 \text{ A/cm}^2$ , ON cooled (means oil immersed, self cooled or natural cooled) transformer having  $\pm 2.5\%$  and  $\pm 5\%$  tapping on high voltage winding

$\phi_m = \frac{E_t}{4.44 f} = \frac{11}{4.44 \times 50} = 0.05 \text{ Wb}$

$A_i = \frac{\phi_m}{B_m} = \frac{0.05}{1.25} = 0.04 \text{ m}^2$

Since  $A_i = 0.6 \text{ d}^2$ ,  $d = \sqrt{\frac{A_i}{0.6}} = \sqrt{\frac{0.04}{0.6}} = 0.26 \text{ m}$

Since  $A_i = 0.6 \text{ d}^2$  corresponds to 3 stepped core,  $a = 0.9d = 0.9 \times 0.26 = 0.234 \text{ m}$

Width or depth of the transformer =  $a = 0.234 \text{ m}$

$H_y = (1.0 \text{ to } 1.5) a = 1.0 a \text{ (say)} = 0.234 \text{ m}$

$\text{kVA} = 3.33 f \delta A_i B_m A_w K_w \times 10^{-3}$   
 $350 = 3.33 \times 50 \times 250 \times 10^4 \times 0.04 \times 1.25 \times A_w \times 0.27 \times 10^{-3}$   
 $A_w = 0.062 \text{ m}^2$

Since window proportion  $\frac{H_w}{W_w}$  is 3 : 1,  $H_w = 3W_w$  and  $A_w = 3W_w^2 = 0.062$

Therefore  $W_w = \sqrt{\frac{0.062}{3}} = 0.143 \text{ m}$  and  $H_w = 3 \times 0.143 = 0.43 \text{ m}$

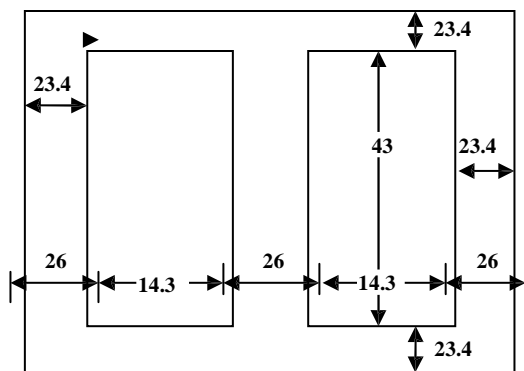

Details of the core

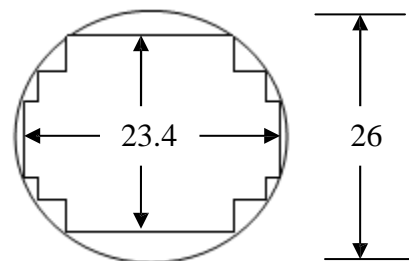

Leg and Yoke section  
All dimensions are in cm

Overall length of the transformer =  $2W_w + 2d + a = 2 \times 14.3 + 2 \times 26 + 23.4 = 104 \text{ cm}$

Overall height of the transformer =  $H_w + 2H_y$  or  $2a = 43 + 2 \times 23.4 = 89.8$  cm

Width or depth of the transformer =  $a = 23.4$  cm

[ with + 2.5% tapping, the secondary voltage will be 1.025 times the rated secondary voltage. To achieve this with fixed number of secondary turns  $T_2$ , the voltage / turn must be increased or the number of primary turns connected across the supply must be reduced.]

$$\text{Number of secondary turns } T_2 = \frac{V_2}{E_t} = \frac{3300}{11} = 300$$

$$\text{Number of primary turns for rated voltage } T_1 = \frac{V_1}{E_t} = \frac{11000 / \sqrt{3}}{11} \approx 577$$

Number of primary turns for + 2.5% tapping =  $T_2 \times E_1$  required  $E_2$  with tapping

$$= 300 \times \frac{11000 / \sqrt{3}}{1.025 \times 3300} \approx 563$$

$$\text{for } -2.5\% \text{ tapping} = 300 \times \frac{11000 / \sqrt{3}}{0.975 \times 3300} \approx 592$$

$$\text{for } +5\% \text{ tapping} = 300 \times \frac{11000 / \sqrt{3}}{1.05 \times 3300} \approx 550$$

$$\text{for } -5\% \text{ tapping} = 300 \times \frac{11000 / \sqrt{3}}{0.95 \times 3300} \approx 608$$

Obviously primary winding will have tapings at 608<sup>th</sup> turn, 592<sup>nd</sup> turn, 577<sup>th</sup> turn, 563<sup>rd</sup> turn and 550<sup>th</sup> turn.

$$\text{primary current / ph } I_1 = \frac{\text{kVA} \times 10^3}{3V_{1\text{ph}}} = \frac{350 \times 10^3}{3 \times 11000 / \sqrt{3}} = 18.4 \text{ A}$$

$$\text{Cross-sectional area of the primary winding conductor } a_1 = I_1 / \delta = 18.4 / 250 = 0.074 \text{ cm}^2$$

$$\text{Secondary current / ph } I_2 = \frac{\text{kVA} \times 10^3}{3V_{2\text{ph}}} = \frac{350 \times 10^3}{3 \times 3300} = 35.35 \text{ A}$$

$$\text{Cross-sectional area of the secondary winding conductor } a_2 = I_2 / \delta = 35.35 / 250 = 0.14 \text{ cm}^2$$

3. Determine the main dimensions of the core, number of turns and cross-sectional area of conductors of primary and secondary of a 125 kVA, 6600 / 460V, 50Hz, Single phase core type distribution transformer. Maximum flux density in the core is 1.2T, current density 250 A/ cm<sup>2</sup>, Assume: a cruciform core allowing 8% for the insulation between laminations. Yoke cross-section as 15% greater than that of the core. Window height = 3 times window width, Net cross-section of copper in the window is 0.23 times the net cross-section of iron in the core, window space factor = 0.3. Draw a neat sketch to a suitable scale.

[Note: 1) for a cruciform core with 10% insulation or  $K_i = 0.9$ ,  $A_i = 0.56d^2$ . With 8% insulation or  $K_i = 0.92$ ,  $A_i = 0.56d^2 \times \frac{0.92}{0.9} = 0.57d^2$

2) Since the yoke cross-sectional area is different from the leg or core area, yoke can considered to be rectangular in section. Yoke area  $A_y = H_y \times K_i a$  ]

$$A_{cu} = A_w K_w = 0.23 A_i \dots\dots (1)$$

$$\text{kVA} = 2.22 f \delta A_i B_m A_w K_w \times 10^{-3}$$

$$125 = 2.22 \times 50 \times 250 \times 10^4 \times A_i \times 1.2 \times 0.23 A_i \times 10^{-3}$$

$$A_i = \sqrt{\frac{125}{2.22 \times 50 \times 250 \times 10^4 \times 1.2 \times 0.23 \times 10^{-3}}} = 0.04 \text{ m}^2$$

Since with 8% insulation,  $A_i = 0.56 d^2 \times 0.92 / 0.9 = 0.57 d^2$ ,  $d = \sqrt{\frac{0.04}{0.57}} = 0.27$  m

Since the expression for the width of the largest stamping is independent of the value of stacking factor,  $a = 0.85 d = 0.85 \times 0.27 = 0.23$  m

Width or depth of the transformer =  $a = 0.23$  m

Since the yoke is rectangular in section  $A_y = H_y \times K_1 a = 1.15 A_i$

Therefore  $H_y = \frac{1.15 A_i}{K_1 a} = \frac{1.15 \times 0.04}{0.92 \times 0.23} = 0.22$  m

From equation 1,  $A_w = \frac{0.23 A_i}{K_w} = \frac{0.23 \times 0.04}{0.3} = 0.031$  m<sup>2</sup>

Since  $H_w = 3W_w$ ,  $A_w = H_w W_w = 3W_w^2 = 0.031$

Therefore  $W_w = \sqrt{\frac{0.031}{3}} = 0.1$  m and  $H_w = 0.1 \times 3 = 0.3$  m

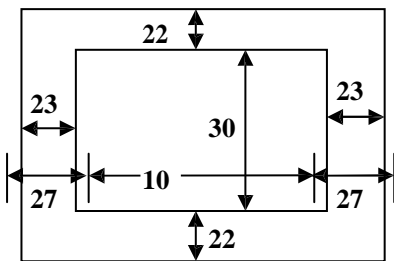

Details of core

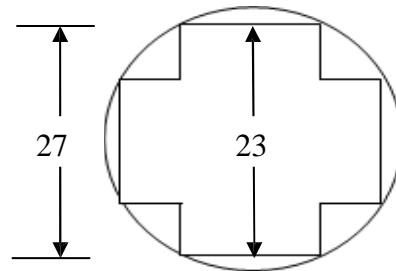

Leg section

All dimensions are in cm

$$T_1 = \frac{V_1}{E_t} \text{ where } E_t = 4.44 \phi_m f = 4.44 A_i B_m f = 4.44 \times 0.04 \times 1.250 = 10.7 \text{ V}$$

$$T_1 = \frac{6600}{10.7} \approx 617$$

$$T_2 = \frac{V_2}{E_t} = \frac{460}{10.7} \approx 43$$

$$I_1 = \frac{\text{kVA} \times 10^3}{V_1} = \frac{125 \times 10^3}{6600} = 18.93 \text{ A}, \quad a_1 = \frac{I_1}{\delta} = \frac{18.93}{250} = 0.076 \text{ cm}^2$$

$$I_2 = \frac{\text{kVA} \times 10^3}{V_2} = \frac{125 \times 10^3}{460} = 271.73 \text{ A}, \quad a_2 = \frac{I_2}{\delta} = \frac{271.73}{250} = 1.087 \text{ cm}^2$$

4. Determine the main dimensions of the core and the number of turns in the primary and secondary windings of a 3 phase, 50 Hz, 6600/(400 – 440) V in steps of 2 ½ %, delta / star transformer. The volt / turn = 8 and the maximum flux densities in the limb and yoke are 1.25 T and 1.1 T respectively. Assume a four stepped core. Window dimensions = 50 cm x 13 cm.

$$\phi_m = \frac{E_i}{4.44 f} = \frac{8}{4.44 \times 50} = 0.036 \text{ Wb}$$

$$A_i = \frac{\phi_m}{1.25} = 0.028 \text{ m}^2$$

=

$$\text{Since for a 4 stepped core } A_i = 0.62d^2, \quad d = \sqrt{\frac{0.028}{0.62}} = 0.21 \text{ m}$$

$$a = 0.93 d = 0.93 \times 0.21 = 0.19 \text{ m}$$

Width or depth of the transformer = a = 0.19 m

$$A_y = \frac{\phi_m}{1.1} = 0.033 \text{ m}^2$$

=

 $B_y$ 

Since the yoke area is different from the leg area, yoke can be considered to be of rectangular section. Therefore

$$H_y = \frac{A_y}{K_i a} = \frac{0.033}{0.9 \times 0.19} = 0.193 \text{ m, with the assumption that } K_i = 0.9$$

Since the window dimensions are given,

$$\text{Length of the transformer} = 2W_w + 2d + a = 2 \times 0.13 + 2 \times 0.21 + 0.19 = 0.87 \text{ m}$$

$$\text{Overall height of the transformer} = a + H_w + 2H_y = 0.5 + 2 \times 0.193 = 0.886 \text{ m}$$

Width or depth of the transformer = 0.19 m

$$T_2 \text{ (for maximum voltage of 440V)} = \frac{440 / \sqrt{3}}{8} = 31$$

$$T_1 \text{ for maximum secondary voltage of 440V} = \frac{V_1}{V_2} \times T_2 = \frac{6600}{440 / \sqrt{3}} \times 31 = 806$$

$$T_1 \text{ for minimum secondary voltage of 400 V} = \frac{6600}{400 / \sqrt{3}} \times 31 = 886$$

Since voltage is to be varied at 2 ½ %, from (400 to 440) V, the tapings are to be provided to get the following voltages 400V, 1.025 x 400 = 410V, 1.05 x 400 = 420V, 1.075 x 400 = 430 V and 1.10 x 400 = 440V. Generally the hV winding is due to number of coils connected in series.

out of the many coils of the hV winding, one coil can be made to have 886 – 806 = 80 turns with tapping facility at every 20 turns to provide a voltage variation of 2 ½ % on the secondary side

5. For the preliminary design of a 100kVA, 50Hz, 11000/3300 V, 3 phase, delta / star, core type distribution transformer, determine the dimensions of the core and window, number of turns and cross-sectional area of HT and LT windings. Assume : Maximum value of flux density 1.2T, current density 2.5 A/mm<sup>2</sup> window space facto 0.3. Use cruciform core cross-section for which iron area  $A_i = 0.56d^2$  and the maximum limit thickness is 0.85d, where d is the diameter of the circumscribing circle volt / turn = 0.6  $\sqrt{\text{kVA}}$ , overall width = overall height.

[NOTE: since overall width = overall height ie., (2W<sub>w</sub> + 2d + a) = (H<sub>w</sub> + 2 H<sub>y</sub> or 2a). this condition when substituted in A<sub>w</sub>=H<sub>w</sub>W<sub>w</sub> leads to a quadratic equation. By solving the same the values of H<sub>w</sub>W<sub>w</sub> can be obtained.]

6. Determine the main dimensions and winding details for a 125 kVA, 2000/400V, 50Hz, Single phase shell type transformer with the following data. Volt / turn = 11.2, flux density = 1.0 T, current density = 2.2 A/mm<sup>2</sup>, window space factor = 0.33. Draw a dimensioned sketch of the magnetic circuit.

Solution:

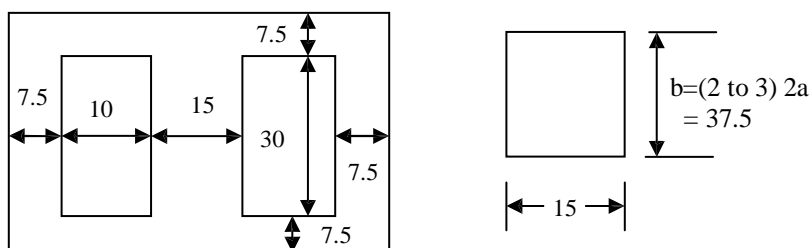



$$\phi_m = \frac{E_t}{4.44 f} = \frac{11.2}{4.44 \times 50} = 0.05 \text{ Wb}$$

Since  $\phi_m$  is established in the Central leg

$$\text{Cross-sectional area of the central leg } A_i = \frac{\phi_m}{B_m} = \frac{0.05}{1.0} = 0.05 \text{ m}^2$$

If a rectangular section core is assumed then  $A_i = 2a \times K_i b = 2a \times K_i \times (2 \text{ to } 3) 2a$

If the width of the transformer  $b$  is assumed to be 2.5 times  $2a$  and  $K_i = 0.9$ , then the width of the

$$\text{central leg } 2a = \sqrt{\frac{A_i}{(2.5) K_i}} = \sqrt{\frac{0.05}{2.5 \times 0.9}} = 0.15 \text{ m}$$

Width or depth of the transformer  $b = 2.5 \times 2a = 2.5 \times 0.15 = 0.375 \text{ m}$

Height of the yoke  $H_y = a = 0.15 / 2 = 0.075 \text{ m}$

$$\text{kVA} = 2.22 f \delta A_i B_m A_w K_w \times 10^{-3}$$

$$125 = 2.22 \times 50 \times 2.2 \times 10^6 \times 0.05 \times 1.0 \times A_w \times 0.33 \times 10^{-3}$$

$$A_w = 0.031 \text{ m}^2$$

[Since the window proportion or a value for  $H_w / W_w$  is not given, it has to be assumed] Since  $H_w / W_w$  lies between 2.5 and 3.5, let it be = 3.0

$$\text{Therefore } A_w = H_w W_w = 3W_w^2 = 0.031$$

$$W_w = \sqrt{\frac{0.031}{3}} = 0.1 \text{ m and } H_w = 3 \times 0.1 = 0.3 \text{ m}$$

Winding details:

$$T_1 = \frac{V_1}{E_t} = \frac{2000}{11.2} \approx 178 \quad T_2 = \frac{400}{11.2} \approx 36$$

$$I_1 = \frac{\text{kVA} \times 10^3}{V_1} = \frac{125 \times 10^3}{2000} = 62.5 \text{ A, } a_1 = \frac{I_1}{\delta} = \frac{62.5}{2.2} = 28.4 \text{ mm}^2$$

$$I_2 = \frac{\text{kVA} \times 10^3}{V_2} = \frac{125 \times 10^3}{400} = 312.5 \text{ A, } a_2 = \frac{I_2}{\delta} = \frac{312.5}{2.2} = 142 \text{ mm}^2$$

Calculate the core and window area and make an estimate of the copper and iron required for a 125 kVA, 2000 / 400 V, 50 Hz single phase shell type transformer from the following data. Flux density = 1.1 T, current density = 2.2 A/mm<sup>2</sup>, volt / turn = 11.2, window space factor = 0.33, specific gravity of copper and iron are 8.9 and 7.8 respectively. The core is rectangular and the stampings are all 7 cm wide.

[Note: A shell type transformer can be regarded as two single phase core type transformers placed one beside the other.]

$$\phi_m = \frac{E_t}{4.44 f} = \frac{11.2}{4.44 \times 50} = 0.05 \text{ Wb}, \quad A_i = \frac{\phi_m}{B_m} = \frac{0.05}{1.1} = 0.045 \text{ m}^2$$

$$\text{kVA} = 2.22 f \delta A_i B_m A_w K_w \times 10^{-3}$$

$$125 = 2.22 \times 50 \times 2.2 \times 10^6 \times 0.045 \times 1.1 \times A_w \times 0.33 \times 10^{-3}$$

$$A_w = 0.03 \text{ m}^2$$

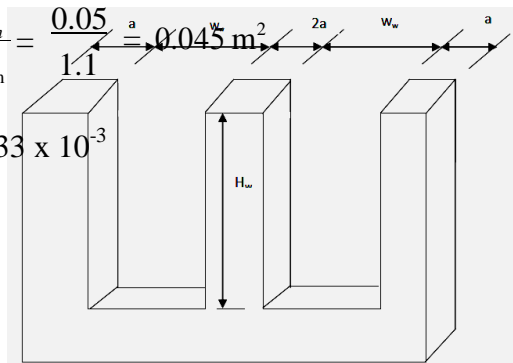
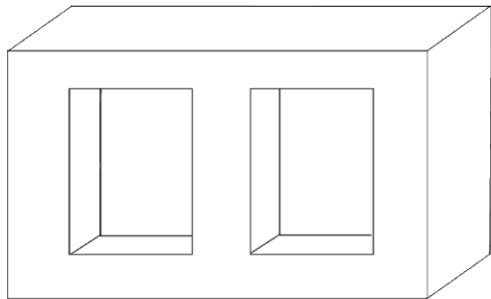

Single phase shell type  
Transformer

Upper yoke  
removed

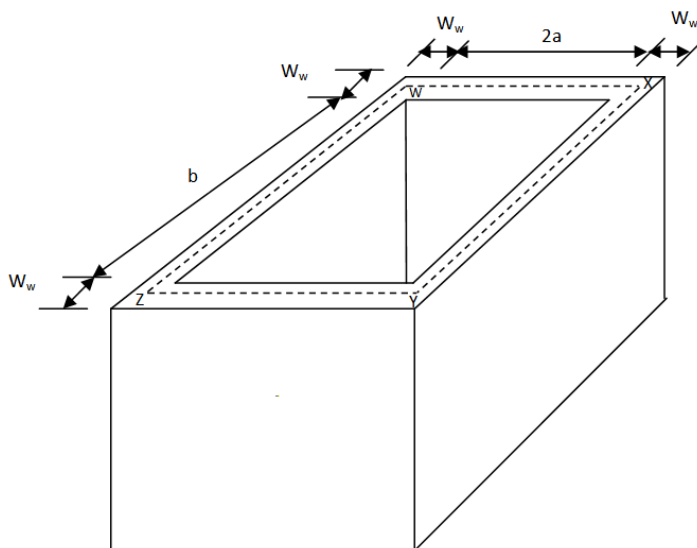

Sketch showing the dimensions of LV & HV windings together

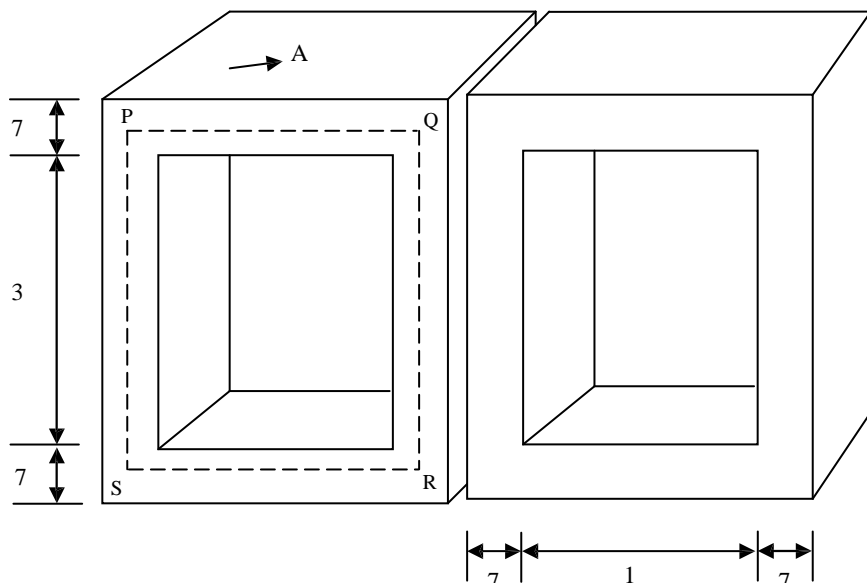

Shell type transformer due to two single phase core type transformers.

If the whole window is assumed to be filled with both LV & HV windings, then the height of the winding is  $H_w$  and width of the LV & HV windings together is  $W_w$ .

$$\begin{aligned} \text{Weight of copper} &= \text{Volume of copper} \times \text{density of copper} \\ &= \text{Area of copper in the winding arrangement} \times \text{mean length of copper} \\ &\quad \text{in the windings} \times \text{density of copper} \\ &= A_w K_w \times \text{length } wxyzw \times \text{density of copper} \end{aligned}$$

$$\text{Mean length } wxyzw = 2 (wx + xy) = 2 [(2a + W_w) + (b + W_w)]$$

Since the stampings are all 7 cm wide,  $a = 7\text{cm}$  &  $2a = 14\text{ cm}$

$$b = \frac{A_i}{K_i 2a} = \frac{0.045}{0.9 \times 0.14} = 0.36\text{ m}$$

Since  $H_w / W_w$  lies between 2.5 and 3.5, let it be 3.0

$$\text{Therefore } A_w = H_w W_w = 3W_w^2 = 0.03.$$

$$\text{Thus } W_w = \sqrt{\frac{0.03}{3}} = 0.1 \text{ m and } H_w = 3 \times 0.1 = 0.3 \text{ m}$$

$$wxyzw = 2 [(14 + 10) + (36 + 10)] = 140 \text{ cm}$$

$$\text{Width of copper} = 0.03 \times 10^4 \times 0.33 \times 140 \times 8.9 \times 10^{-3} = 123.4 \text{ kg}$$

Weight of iron = 2 x volume of the portion A x density of iron

$$\begin{aligned} &= 2 \times \frac{A_i}{2} \times \text{Mean core length} \\ &\quad \text{PQRSP} \times \text{density of iron} \\ &= 2 \times \frac{0.045}{2} \times 10^4 \times 2 [(10+7) + (30 + 7)] \times 7.8 \times 10^{-3} = 379 \text{ kg} \end{aligned}$$

7. Determine the main dimensions of a 350kVA, 3 phase, 50Hz, Star/delta, 11000 / 3300 V core type distribution transformer. Assume distance between core centres is twice the width of the core.

$$\text{For a 3 phase core type distribution transformer } E_t = 0.45 \sqrt{\text{kVA}} = 0.45 \sqrt{350} = 8.4$$

$$\phi_m = \frac{E_t}{4.44 f} = \frac{8.4}{4.44 \times 50} = 0.038 \text{ Wb}, \quad A_i = \frac{\phi_m}{B_m}$$

Since the flux density  $B_m$  in the limb lies between (1.1 & 1.4) T, let it be 1.2 T.

$$\text{Therefore } A_i = \frac{0.038}{1.2} = 0.032 \text{ m}^2$$

$$\text{If a 3 stepped core is used then } A_i = 0.6 d^2. \text{ Therefore } d = \sqrt{\frac{0.032}{0.6}} = 0.23 \text{ m}$$

$$a = 0.9d = 0.9 \times 0.23 \approx 0.21 \text{ m}$$

$$\text{Width or depth of the transformer} = a = 0.21 \text{ m}$$

$$H_y = (1.0 \text{ to } 1.5) a = a = 0.21 \text{ m}$$

$$\text{kVA} = 3.33 f \delta A_i B_m A_w K_w \times 10^{-3}$$

If natural cooling is considered (upto 25000 kVA, natural cooling can be used), then current density lies between 2.0 and 3.2 A/mm<sup>2</sup>. Let it be 2.5 A/mm<sup>2</sup>.

$$K_w = \frac{10}{30 + K_{v_{hv}}} = \frac{10}{30 + 11} = 0.24$$

$$350 = 3.33 \times 50 \times 2.5 \times 10^6 \times 0.032 \times 1.2 \times A_w \times 0.24 \times 10^{-3}$$

$$A_w = 0.09 \text{ m}^2$$

$$\text{Since } W_w + d = 2a, \quad W_w = 2 \times 0.21 - 0.23 = 0.19 \text{ m and } H_w = \frac{A_w}{W_w} = \frac{0.09}{0.19} \approx 0.47 \text{ m}$$

$$\text{Overall length of the transformer} = W_w + 2d + a = 0.19 + 2 \times 0.23 + 0.21 = 0.86 \text{ m}$$

$$\text{Overall height of the transformer} = H_w + 2 H_y = 0.47 + 2 \times 0.21 = 0.89 \text{ m}$$

$$\text{Width or depth of the transformer} = 0.21 \text{ m}$$

### Problems on No load current

1. Calculate the no load current and power factor of a 3300/220 V, 50Hz, single phase core type transformer with the following data. Mean length of the magnetic path = 300 cm, gross area of iron core = 150 cm<sup>2</sup>, specific iron loss at 50 Hz and 1.1 T = 2.1 W / kg ampere turns / cm for transformer steel at 1.1T = 6.2. The effect of joint is equivalent to

an air gap of 1.0 mm in the magnetic circuit. Density of iron = 7.5 grams / cc. Iron factor = 0.92

Solution:

$$\text{No-load current } I_0 = \sqrt{I_c^2 + I_m^2}$$

$$\text{Core loss component of the no load current } I_c = \frac{\text{Core loss}}{V_1}$$

$$\begin{aligned} \text{Core loss} &= \text{loss / kg} \times \text{volume of the core} \times \text{density of iron} \\ &= \text{loss / kg} \times \text{net iron area} \times \text{mean length of the core or} \\ &\quad \text{magnetic path} \times \text{density of iron} \\ &= 2.1 \times 0.92 \times 150 \times 300 \times 7.5 \times 10^{-3} = 656.4 \text{ W} \end{aligned}$$

$$\text{Therefore } I_c = \frac{656.4}{3300} = 0.198 \text{ A}$$

$$\text{Magnetising current } I_m = \frac{AT_{\text{iron}} + 800000 l_g B_m}{\sqrt{2} T_1}$$

$$\begin{aligned} AT_{\text{iron}} &= AT/\text{cm} \times \text{mean length of the magnetic path in cm} \\ &= 6.2 \times 300 = 1800 \end{aligned}$$

$$\begin{aligned} T_1 &= \frac{V_1}{E_t} \text{ where } E_t = 4.44 \phi f \\ &= 4.44 A_i B_m f \\ &= 4.44 (K_i A_g) B_m f \\ &= 4.44 \times 0.92 \times 150 \times 10^{-4} \times 1.1 \times 50 \\ &= 3.37 \text{ V} \end{aligned}$$

$$T_1 = \frac{3300}{3.37} \approx 980$$

$$I_m = \frac{1860 + 800000 \times 1 \times 10^{-3} \times 1.1}{\sqrt{2} \times 980} = 1.98 \text{ A}$$

$$I_0 = \sqrt{0.198^2 + 1.98^2} = 1.99 \text{ A}$$

$$\text{No-load power factor } \cos \phi_0 = \frac{I_c}{I_0} = \frac{0.198}{1.98} = 0.1$$

2. Calculate the no-load current of a 220/110V, 1kVA, 50Hz, Single phase transformer with the following data uniform cross-sectional area of the core = 25 cm<sup>2</sup>, effective magnetic core length = 0.4m, core weight = 8 kg, maximum flux density = 1.2 T, magnetizing force = 200 AT/m, specific core loss = 1.0 W/kg

$$I_0 = \sqrt{I_c^2 + I_m^2}$$

$$\begin{aligned} I_c &= \frac{\text{Core loss}}{V_1} \\ &= \frac{\text{loss / kg} \times \text{weight of core in kg}}{V_1} = \frac{1 \times 8}{220} = 0.036 \text{ A} \end{aligned}$$

$$I_m = \frac{AT_{\text{for iron}} + 800000 l_g B_m}{\sqrt{2} T_1} = \frac{AT_{\text{for iron}}}{\sqrt{2} T_1}$$

as there is no data about the effect of joints or  $l_g$  is assumed to be zero

$$\begin{aligned} AT_{\text{for iron}} &= AT / \text{m} \times \text{Effective magnetic core length} \\ &= 200 \times 0.4 = 80 \end{aligned}$$

$$T_1 = \frac{V_1}{E_t} \text{ where } E = 4.44 \phi f$$

$$= 4.44 A_i B_m f$$

$$= 4.44 (K_i A_g) B_m f$$

$$= 4.44 \times 0.9 \times 25 \times 10^{-4} \times 1.2 \times 50 \text{ if } K_i = 0.9$$

$$= 0.6V$$

$$T_1 = \frac{220}{0.6} \approx 367$$

$$I_m = \frac{80}{\sqrt{2} \times 367} \approx 0.154 \text{ A}$$

$$I_0 = \sqrt{0.036^2 + 0.154^2} = 0.158 \text{ A}$$

3. A 300 kVA, 6600/400V, delta / star, 50Hz, 3 phase core type transformer has the following data. Number of turns/ph on HV winding = 830, net iron area of each limb and yoke = 260 and 297 cm<sup>2</sup>, Mean length of the flux path in each limb and yoke = 55 cm and 86.9 cm. For the transformer steel

Flux density in tesla-	0.75	1.0	1.15	1.25	1.3	1.35	1.4
AT/m	- 100	105	200	400	500	1000	1500
Coreloss / kg	- 0.7	1.25	1.75	2.1	2.3	2.6	2.8

Determine the no load current

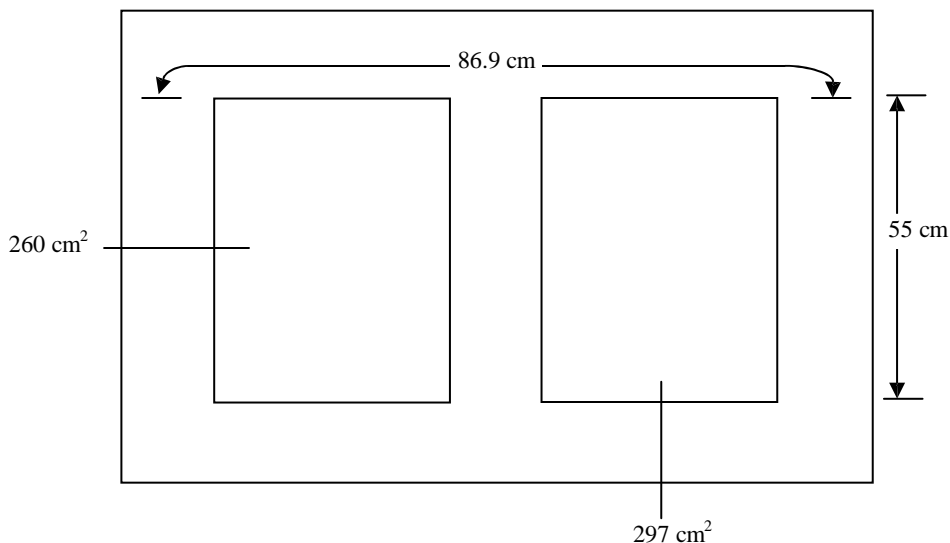

Core and Yoke details

Solution:  $I_0 = \sqrt{I_c^2 + I_m^2}$

$$I_c = \frac{\text{Coreloss / ph}}{V_{1ph}}$$

$$\text{Coreloss / ph} = \frac{\text{loss in 3 legs} + \text{loss in 2 yokes}}{3}$$

Loss in 3 legs = 3 x loss in one leg  
 = 3 x loss / kg in leg x volume of the leg i.e, (A<sub>i</sub> x mean length of the flux Path in leg) x density of iron

$$B_m = \frac{\phi_m}{A_i} \text{ where } \phi = \frac{V_1}{4.44 \times 50 \times 830} = 0.036 \text{ Wb}$$

$$= \frac{V_1}{4.44 f T_1}$$

$$B_m = \frac{0.036}{260 \times 10^{-4}} = 1.38 \text{ T}$$

At 1.38 T, loss / kg in the leg = 2.7 as obtained from the loss/kg graph drawn to scale.

Loss in 3 legs =  $3 \times 2.7 \times 260 \times 55 \times 7.55 \times 10^{-3} = 874.5 \text{ W}$  with the assumption that density of iron is 7.5 grams / cc

Loss in 2 yokes = 2 x loss in one yoke

= 2 x loss/kg in yoke x volume of the yoke i.e, ( $A_y \times$  mean length of the flux path in the yoke) x density of iron

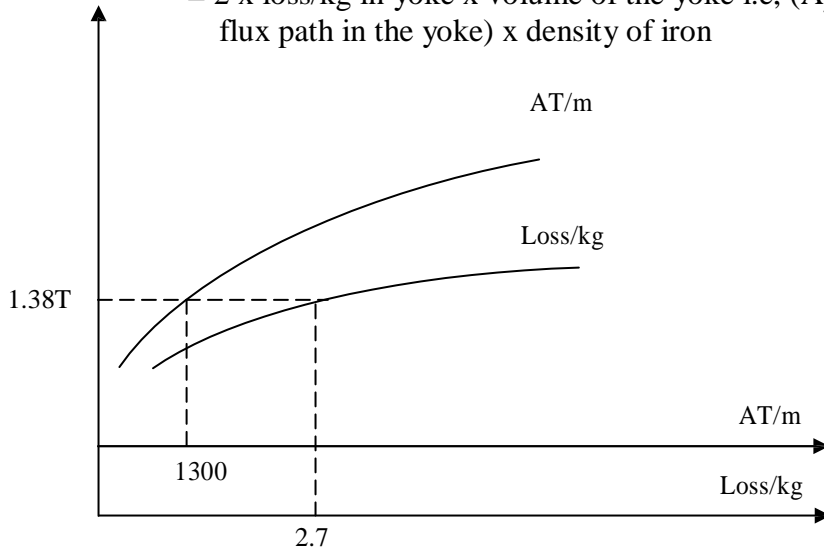

$$B_y = \frac{\phi_m}{A_y} = \frac{0.036}{297 \times 10^{-4}} = 1.21 \text{ T}$$

At 1.21T, loss/kg in yoke = 1.9

Loss in 2 yokes =  $2 \times 1.9 \times 297 \times 86.9 \times 7.55 \times 10^{-3} = 740.5 \text{ W}$

$$\text{Coreloss / ph} = \frac{874.5 + 740.5}{3} = 538.7 \text{ W}$$

$$I_c = \frac{538.7}{6600} = 0.08 \text{ A}$$

$$I_m = \frac{(AT_{\text{for iron}} + 800000 I_g B_m) / \text{ph}}{\sqrt{2} T_1} = \frac{AT_{\text{for iron}} / \text{ph}}{\sqrt{2} T_1} \text{ as there is no data about } I_g$$

$$AT_{\text{for iron}} / \text{ph} = \frac{ATs \text{ for 3 legs} + ATs \text{ for 2 yokes}}{3}$$

$$= \frac{3 \times AT/m \text{ for leg} \times \text{mean length of the flux path in the leg} + 2 \times AT/m \text{ for yoke} \times \text{mean length of the flux path in the yoke}}{3}$$

At  $B_m = 1.38 \text{ T}$ , AT/m for the leg = 1300 and

At  $B_y = 1.21 \text{ T}$ , AT/m for the yoke = 300 as obtained from the magnetization curve drawn to scale.

$$\text{Therefore } AT_{\text{for iron}} / \text{ph} = \frac{3 \times 1300 \times 0.55 + 2 \times 300 \times 0.869}{3} = 888.8$$

$$I_m = \frac{888.8}{\sqrt{2} \times 830} = 0.76 \text{ A}$$

$$I_0 = \sqrt{0.08^2 + 0.76^2} = 0.764 \text{ A}$$

4. A 6600V, 50Hz single phase transformer has a core of sheet steel. The net iron cross sectional area is  $22.6 \times 10^{-3} \text{ m}^2$ , the mean length is 2.23m and there are four lap joints. Each lap joint takes ¼ times as much reactive mmf as is required per meter of core. If the maximum flux density as

1.1T, find the active and reactive components of the no load current. Assume an amplitude factor of 1.52 and mmf / m = 232, specific loss = 1.76 W/kg, specific gravity of plates = 7.5

$$\text{Active component of no load current } I_c = \frac{\text{Coreloss}}{V_1}$$

$$\begin{aligned} \text{Coreloss} &= \text{specific core loss} \times \text{volume of core} \times \text{density} \\ &= 1.76 \times 22.6 \times 10^{-3} \times 2.23 \times 7.5 \times 10^3 = 665.3 \text{ W} \end{aligned}$$

$$I_c = \frac{665.3}{6600} = 0.1 \text{ A}$$

$$\text{Reactive component of the no-load current } I_m = \frac{AT_{\text{iron}} + 800000 l_g B_m}{1.52 T_1} \text{ as peak, crest or}$$

$$\text{amplitude factor} = \frac{\text{Maximum value}}{\text{rms value}} = 1.52$$

$$AT_{\text{iron}} = 232 \times 2.23 = 517.4$$

$$AT \text{ for 4 lap joints} = 800000 l_g B_m = 4 \times \frac{1}{4} \times 232 = 232$$

$$T_1 = \frac{V_1}{4.44 \phi_m f} = \frac{V_1}{4.44 A_i B_m f} = \frac{6600}{4.44 \times 22.6 \times 10^{-3} \times 1.1 \times 50} \approx 1196$$

$$I_m = \frac{517.4 + 232}{1.52 \times 1196} = 0.412 \text{ A}$$

5. A single phase 400V, 50Hz, transformer is built from stampings having a relative permeability of 1000. The length of the flux path 2.5m,  $A_i = 2.5 \times 10^{-3} \text{ m}^2$ ,  $T_1 = 800$ . Estimate the no load current. Iron loss at the working flux density is 2.6 W/kg. Iron weights  $7.8 \times 10^3 \text{ kg/m}^3$ , iron factor = 0.9

[Hint:  $B_m = \mu_0 \mu_r H$ ,  $AT_{\text{iron}} = H \times \text{flux path length}$ ]

### Problems on Leakage reactance

1. Calculate the percentage reactance of a 15 kVA, 11000/440V, star-delta, 50Hz transformer with cylindrical coils of equal length, given the following. Height of the coils = 25cm, thickness of LV = 4cm, thickness of HV = 3 cm, mean diameter of both primary and secondary together = 15 cm, insulation between HV & LV = 0.5cm, volt / turn = 2, transformer is of core type

$$\text{Percentage reactance } \epsilon_x = \frac{I_1 X_p}{V_1} \times 100$$

$$I_1 = \frac{\text{kVA} \times 10^3}{3 V_1} = \frac{15 \times 10^3}{3 \times 11000 / \sqrt{3}} = 0.8 \text{ A}$$

$$X_p = 2 \pi f T_p^2 \mu_0 \left[ \frac{L_{mt}}{L_c} \frac{b_p}{3} + \frac{b}{3} + a \right]$$

$$T_p = T_s = \frac{V_1}{E_t} = \frac{11000 / \sqrt{3}}{2} = 3176$$

$$\begin{aligned} L_{mt} &= \text{Mean length of turn of both primary and secondary together} \\ &= \pi \times \text{mean diameter of both primary and secondary together} \\ &= \pi \times 15 = 47.1 \text{ cm} \end{aligned}$$

$$X_p = 2 \pi \times 50 \times (3176)^2 \times 4\pi \times 10^{-7} \times \left[ \frac{0.471}{0.03} + \frac{0.04}{3} + 0.005 \right] = 212.13 \Omega$$

$$\epsilon_x = \frac{0.8 \times 212.13}{11000 / \sqrt{3}} \times 100 = 2.67$$

2. Determine the equivalent reactance of a transformer referred to the primary from the following data. Length of the mean turn of primary and secondary = 120 cm and 100 cm number of primary and secondary turns = 500 and 20. Radial width of both windings = 2.5 cm, width of duct between two windings = 1.4 cm, height of coils = 60 cm.

$$X_p = 2 \pi f T_p^2 \mu_0 \frac{L_{mt}}{L_c} \left[ \frac{b_p}{3} + \frac{b}{3} + a \right]$$

$L_{mt}$  = Mean length of turn of both primary and secondary together

$$= \pi \times (1.2 + 1.0) / 2 = 3.46 \text{ m}$$

$$= 2 \pi \times 50 \times 500^2 \times 4\pi \times 10^{-7} \times \frac{3.46}{0.6} \left[ \frac{0.025}{3} + \frac{0.025}{3} + 0.014 \right] \approx 5.55 \Omega$$

OR

$$X_p = x_p + x'_s = x_p + x_s (T_p / T_s)^2$$

$$x_p = 2 \pi f T_p^2 \mu_0 \frac{L_{mp}}{L_c} \left[ \frac{b_p}{3} + \frac{a}{2} \right]$$

$$= 2 \pi \times 50 \times 500^2 \times 4\pi \times 10^{-7} \times \frac{1.2}{0.6} \left[ \frac{0.025}{3} + \frac{0.014}{2} \right] = 3.03 \Omega$$

$$x_s = 2 \pi f T_s^2 \mu_0 \frac{L_{ms}}{L_c} \left[ \frac{b_s}{3} + \frac{a}{2} \right]$$

$$= 2 \pi \times 50 \times 20^2 \times 4\pi \times 10^{-7} \times \frac{1.0}{0.6} \left[ \frac{0.025}{3} + \frac{0.014}{2} \right] = 4.03 \times 10^{-3} \Omega$$

$$X_p = 3.03 + 4.03 \times 10^{-3} \times \left( \frac{500}{20} \right)^2 = 5.55 \Omega$$

3. Calculate the percentage regulation at full load 0.8pf lag for a 300 kVA, 6600/440V, delta-star, 3 phase, 50Hz, core type transformer having cylindrical coils of equal length with the following data. Height of coils = 4.7 cm, thickness of HV coil = 1.6 cm, thickness of LV coil = 2.5 cm, insulation between LV & HV coils = 1.4 cm, Mean diameter of the coils = 27 cm, volt/turns = 7.9 V, full load copper loss = 3.75 Kw

$$\text{Percentage regulation} = \frac{I_1 R_p \cos \phi + I_1 X_p \sin \phi}{V_1} \times 100$$

$$I_1 = \frac{\text{kVA} \times 10^3}{3 V_1} = \frac{300 \times 10^3}{3 \times 6600} = 15.15 \text{ A}$$

$$\text{Since full load copper loss} = 3 I_1^2 R_p, \quad R_p = \frac{3.75 \times 10^3}{3 \times (15.15)^2} = 5.45 \Omega$$

$$X_p = 2 \pi f T_p^2 \mu_0 \frac{L_{mt}}{L_c} \left[ \frac{b_p}{3} + \frac{b}{3} + a \right]$$

$$T_p = T_s = \frac{V_1}{E_t} = \frac{6600}{7.9} \approx 836$$

$$L_{mt} = \text{Mean length of turn of both primary \& secondary together} = \pi \times 27 = 84.82 \text{ cm}$$



$$X_p = 2 \pi \times 50 \times (836) \times 4\pi \times 10^{-7} \times \left[ \frac{0.8482}{0.016} + \frac{0.025}{3} + 0.014 \right] = 13.77\Omega$$

$$\text{Percentage regulation} = \frac{15.15 \times 5.45 \times 0.8 + 15.15 \times 13.77 \times 0.6}{6600} \times 100 = 2.89$$

4. A 750 kVA, 6600/415V, 50Hz, 3 phase, delta – star, core type transformer has the following data. Width of LV winding = 3 cm, width of HV winding = 2.5 cm, width of duct and insulation between LV & HV = 1.0 cm, height of windings = 40 cm, length of mean turn = 150 cm, volt / turn = 10V. Estimate the leakage reactance of the transformer. Also estimate the per unit regulation at 0.8 pf lag, if maximum efficiency of the transformer is 98% and occurs at 85 % of full load.

$$X_p = 2 \pi f T_p^2 \mu_0 \left[ \frac{L_{mt}}{L_c} \frac{b_p}{3} + \frac{b}{3} + a \right]$$

$$T_p = T_s = \frac{V_1}{E_t} = \frac{6600}{10} = 660$$

$$X_p = 2 \pi \times 50 \times (660)^2 \times 4\pi \times 10^{-7} \times \left[ \frac{1.5}{0.4} + \frac{0.03}{0.01} + \frac{0.03}{3} \right] = 18.3\Omega$$

$$\text{Per unit regulation} = \frac{I_1 R_p \cos\phi + I_1 X_p \sin\phi}{V_1}$$

$$I_1 = \frac{\text{kVA} \times 10^3}{3 V_1} = \frac{750 \times 10^3}{3 \times 6600} = 37.88\text{A}$$

Since copper loss = iron loss at maximum efficiency,

$$\text{Losses} = W_{Cu} + W_i = 2 W_{Cu} = 2 \times 3 (0.85 I_1)^2 R_p = \frac{1-\eta}{\eta} \times \text{output}$$

$$\text{Therefore } R_p = \frac{\frac{1-0.98}{0.98} \times 0.85 \times 750 \times 10^3 \times 1.0}{2 \times 3 \times 37.88^2 \times 0.85^2} = 2.01\Omega$$

$$\text{Per unit regulation} = \frac{37.88 \times 2.01 \times 0.8 + 37.88 \times 18.3 \times 0.6}{6600} = 0.072$$

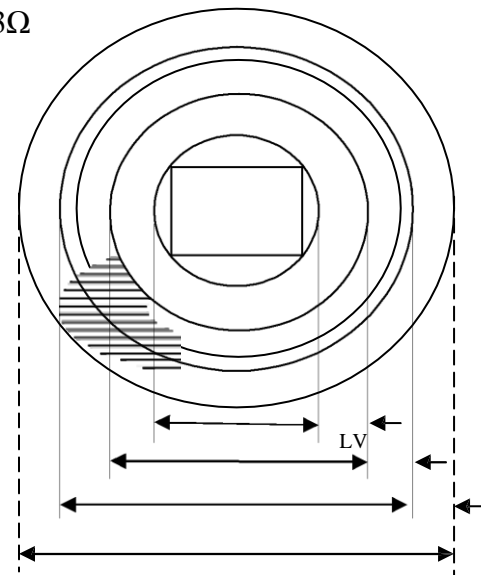

22      b<sub>s</sub>  
 26.5      a  
 29.5      b<sub>p</sub>  
 36

5. Estimate the percentage regulation at full load 0.8 pf lag for a 300 kVA, 6600/400V, delta-star connected core type transformer with the following data.

	Diameter		Cross-sectional area of the conductor
	inside	outside	
HV winding	29.5 cm	36 cm	5.4 mm <sup>2</sup>
LV winding	22 cm	26.5 cm	70 mm <sup>2</sup>

Length of coils = 50 cm, volt/turn = 8, Resistivity = 0.021 Ω / m / mm<sup>2</sup>

$$\text{Solution: Percentage regulation} = \frac{I_1 R_p \cos\phi + I_1 X_p \sin\phi}{V_1} \times 100$$

$$I_1 = \frac{\text{kVA} \times 10^3}{3 V_1} = \frac{300 \times 10^3}{3 \times 6600} = 15.15\text{A}$$

$$R_p = r_p + r_s^1 = r_p + r_s (T_p / T_s)^2$$

$$\text{Resistance of the primary } r_p = \frac{\rho L_{mtp}}{a_1 T_p}$$

$$L_{mtp} = \pi \times \text{mean diameter of primary i.e., HV winding} = \pi \frac{(36 + 29.5)}{2} = 102.9 \text{ cm}$$

$$T_p = \frac{V_1}{E_t} = \frac{6600}{8} = 825. \text{ Therefore, } r_p = \frac{(0.021 \times 1.029 \times 825)}{5.4} = 3.3 \Omega$$

$$\text{Resistance of the secondary } r_s = \frac{\rho L_{mts}}{a_2 T_s}$$

$$L_{mts} = \pi \times \text{mean diameter of secondary i.e., LV winding} = \pi \frac{(26.5 + 22)}{2} = 76.2 \text{ cm}$$

$$T_s = \frac{V_2}{E_t} = \frac{400/\sqrt{3}}{8} \approx 29. \text{ Therefore, } r_s = \frac{(0.021 \times 0.762 \times 29)}{70} = 6.63 \times 10^{-3} \Omega$$

$$R_p = 3.3 + 6.63 \times 10^{-3} \times \frac{825^2}{29} = 8.66 \Omega$$

$$X_p = 2 \pi f T_p^2 \mu_0 \frac{L_{mt}}{L_c} \left[ \frac{b_p}{3} + \frac{b_s}{3} + a \right]$$

$L_{mt}$  = Mean length of turn of both primary & secondary together

=  $\pi$  x mean diameter of both coils

$$= \pi \times \frac{(22 + 36)}{2} = 91.1 \text{ cm or can be taken as } = \frac{102.9 + 76.2}{2} = 89.6 \text{ cm}$$

$$\text{width of primary or HV winding } b_p = \frac{36 - 29.5}{2} = 3.25 \text{ cm}$$

$$\text{width of secondary or LV winding } b_s = \frac{26.5 - 22}{2} = 2.25 \text{ cm}$$

$$\text{width of insulation or duct or both between LV & HV i.e., } a = \frac{29.5 - 26.5}{2} = 1.5 \text{ cm}$$

$$X_p = 2\pi \times 50 \times 825^2 \times 4\pi \times 10^{-7} \times \frac{0.911}{0.5} \left[ \frac{0.0325}{3} + \frac{0.0225}{3} + 0.015 \right] = 16.32 \Omega$$

$$\text{Percentage regulation} = \frac{15.15 \times 8.66 \times 0.8 + 15.15 \times 16.32 \times 0.6}{6600} \times 100 = 3.84$$

### Design of cooling tank and tubes

1. Design a suitable cooling tank with cooling tubes for a 500 kVA, 6600/440V, 50Hz, 3 phase transformer with the following data. Dimensions of the transformer are 100 cm height, 96 cm length and 47 cm breadth. Total losses = 7 kw. Allowable temperature rise for the tank walls is 35°C. Tubes of 5 cm diameter are to be used. Determine the number of tubes required and their possible arrangement.

Tank height  $H_t$  = transformer height + clearance of 30 to 60 cm = 100 + 50 = 150 cm

Tank length  $L_t$  = transformer length + clearance of 10 to 20 cm = 96 + 14 = 110 cm

width or breadth of the tank  $W_t$  = transformer width or breadth + clearance of 10 to 20 cm

$$= \text{clearance of } 47 + 13 = 60 \text{ cm}$$

$$\text{Losses} = 12.5 S_t \theta + 8.78 A_t \theta$$

Dissipating surface of the tank (neglecting the top and bottom surfaces)

$$S_t = 2H_t (L_t + W_t) = 2 \times 1.5 (1.1 + 0.6) = 5.1 \text{ m}^2$$

$$7000 = 12.5 \times 5.1 \times 35 + 8.78 A_t \times 35$$

$$\text{Area of all the tubes } A_t = 15.6 \text{ m}^2$$

Dissipating area of each tube  $a_t = \pi \times \text{diameter of the tube} \times \text{average height or length of the tube}$   
 $= \pi \times 0.05 \times 0.9 \times 1.5 = 0.212 \text{ m}^2$

$$\frac{A_t}{a_t} = \frac{15.6}{0.212} = 73.6 \text{ \& is not possible. Let it be 74.}$$

$$\text{Number of tubes } n_t = \frac{A_t}{a_t} = 73.6$$

If the tubes are placed at 7.5 cm apart from centre to centre, then the number of tubes that can be provided along 110 cm and 60 cm sides are  $\frac{110}{7.5} \approx 15$  and  $\frac{60}{7.5} \approx 8$  respectively.

Therefore number of tubes that can be provided in one row all-round =  $2(15 + 8) = 46$ . Since there are 74 tubes, tubes are to be arranged in 2<sup>nd</sup> row also. If 46 more tubes are provided in second row, then total number of tubes provided will be 92 and is much more than 74. With 13 & 6 tubes along 100 cm & 60 cm sides as shown, total number of tubes provided will be  $2(13 + 6) = 38$  though 74 are only required.

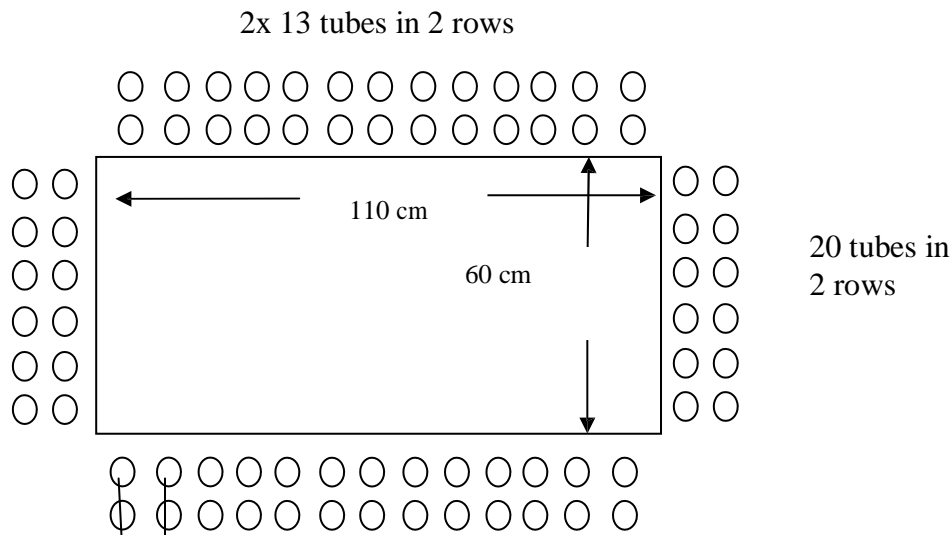

Plan showing the arrangement of tubes

2. A 3 phase 15 MVA, 33/6.6 kV, 50 Hz, star/delta core type oil immersed natural cooled transformer gave the following results during the design calculations. Length of core + 2 times height of yoke = 250 cm, centre to centre distance of cores = 80 cm, outside diameter of the HV winding = 78.5 cm, iron losses = 26 kw, copper loss in LV and HV windings = 41.5 kW & 57.5 kW respectively.

Calculate the main dimensions of the tank, temperature rise of the transformer without cooling tubes, and number of tubes for a temperature rise not to exceed 50°C.

Comment upon whether tubes can be used in a practical case for such a transformer. If not suggest the change.

$$H_t = 250 + \text{clearance of (30 to 60) cm} = 250 + 50 = 300 \text{ cm}$$

$$L_t = 2 \times 80 + 78.5 + \text{clearance of (10 to 20) cm} = 238.5 + 11.5 = 250 \text{ cm}$$

$$W_t = 78.5 + \text{clearance of (10 to 20) cm} = 78.5 + 11.5 = 90 \text{ cm}$$

$$\text{Without tubes, losses} = 12.5 S_t \theta$$

$$S_t = 2 H_t (L_t + W_t) = 2 \times 3 (2.5 + 0.9) = 20.4 \text{ m}^2$$

$$\theta = \frac{(26 + 41.5 + 57.5) 10^3}{12.5 \times 20.4} = 490^\circ\text{C}$$

with cooling tubes, losses =  $12.5 S_t \theta + 8.78 A_t \theta$

$$A_t = \frac{(26 + 41.5 + 57.5) 10^3 - 12.5 \times 20.4 \times 50}{8.78 \times 50} = 255.6 \text{ m}^2$$

With 5 cm diameter tubes  $a_t = \pi \times 0.05 \times 0.9 \times 3 = 0.424 \text{ m}^2$

$$n_t = \frac{255.6}{0.424} \approx 603$$

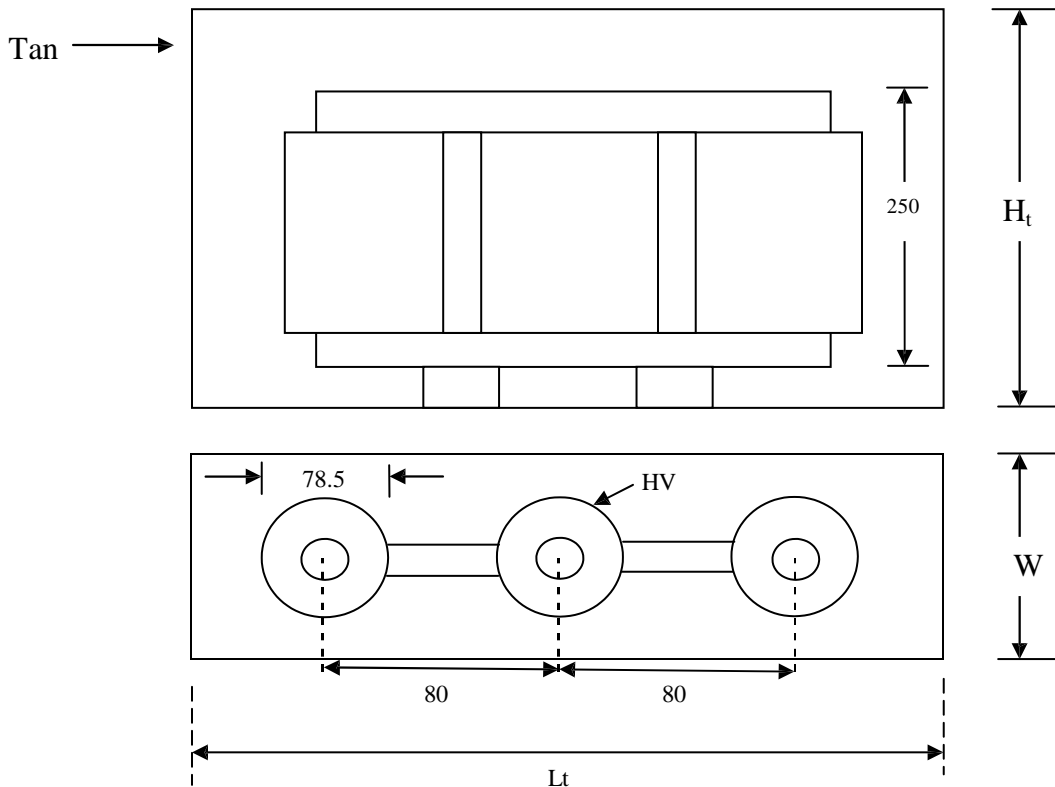

All dimensions are in cms.

If tubes are provided at 7.5 cm apart from centre to centre, then the number of tubes that can be provided along 250 cm and 90 cm sides are  $250 / 7.5 \approx 33$  and  $90 / 7.5 \approx 12$  respectively.

Number of tubes in one row =  $2 (33 + 12) = 90$ .

Therefore number of rows required =  $603 / 90 \approx 7$ .

As the number tubes and rows increases, the dissipation will not proportionately increase. Also it is difficult to accommodate large number of tubes on the sides of the tank. In such cases external radiator tanks are preferable & economical.

3. The tank of a 1250 kVA natural cooled transformer is 155 cm in height and 65 cm x 185 cm in plan. Find the number of rectangular tubes of cross section 10 cm x 2.5 cm. Assume improvement in convection due to siphoning action of the tubes as 40%. Temperature rise =  $40^\circ\text{C}$ . Neglect top and bottom surfaces of the tank as regards cooling. Full load loss is 13.1 kw.

$$\text{Loss} = 12.5 S_t \theta + 1.4 \times 6.5 A_t \theta$$

$$13100 = 12.5 \times [ 2 \times 1.55 (0.65 + 18.5) ] \times 40 + 1.4 \times 6.5 \times A_t \times 40$$

$$A_t = 25.34 \text{ m}^2$$

$a_t$  = dissipating perimeter of the tube x average height of the tube

$$= 2 (10 + 2.5) \times 10^{-2} \times 0.9 \times 1.55 = 0.349 \text{ m}^2$$

$$\eta = \frac{A_t}{a_t} \frac{25.34}{0.349} \approx 72$$

If the tubes are provided at 5 cm apart (from centre to centre of the tubes) then the number of tubes that can be provided along 185 cm side are =  $\frac{185}{5} = 37$ . With 36 tubes on each side of 185 cm tank length, number of tubes provided =  $2 \times 36 = 72$ , as required.

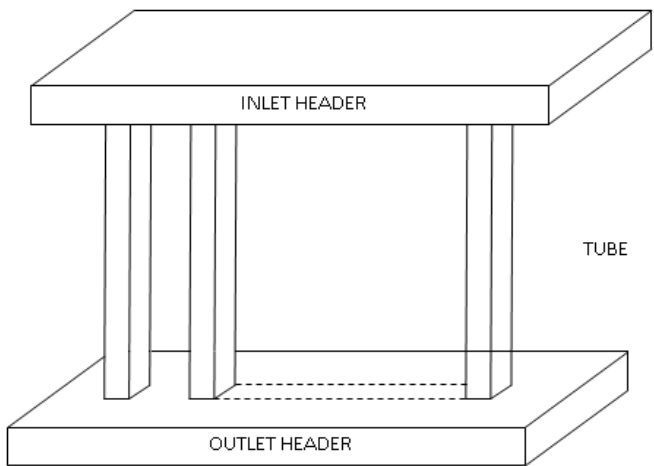
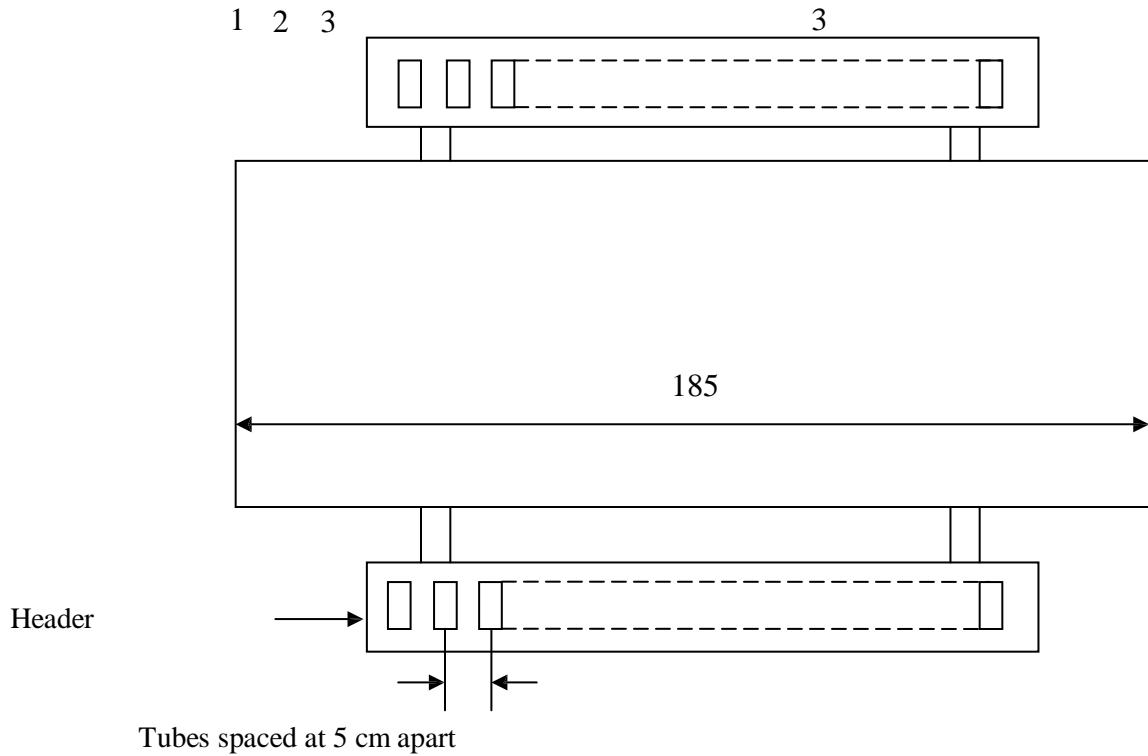

**UNIT -5 & 6**

**DESIGN OF INDUCTION MOTORS:** Output equation, Choice of specific loadings, main dimensions of three phase induction motor, Stator winding design, choice of length of the air gap, estimation of number of slots for the squirrel cage rotor, design of Rotor bars and end ring, design of Slip ring induction motor, estimation of No load current and leakage reactance, and circle diagram. 14 Hours

## **Design of Induction Motors**

**Introduction:**

Induction motors are the ac motors which are employed as the prime movers in most of the industries. Such motors are widely used in industrial applications from small workshops to large industries. These motors are employed in applications such as centrifugal pumps, conveyers, compressors crushers, and drilling machines etc.

**Constructional Details:**

Similar to DC machines an induction motor consists of a stationary member called stator and a rotating member called rotor. However the induction motor differs from a dc machine in the following aspects.

1. Laminated stator
2. Absence of commutator
3. Uniform and small air gap
4. Practically almost constant speed

The AC induction motor comprises two electromagnetic parts:

- Stationary part called the stator
- Rotating part called the rotor

The stator and the rotor are each made up of

- An electric circuit, usually made of insulated copper or aluminum winding, to carry current
- A magnetic circuit, usually made from laminated silicon steel, to carry magnetic flux

### **The stator**

The stator is the outer stationary part of the motor, which consists of

- The outer cylindrical frame of the motor or yoke, which is made either of welded sheet steel, cast iron or cast aluminum alloy.
- The magnetic path, which comprises a set of slotted steel laminations called stator core pressed into the cylindrical space inside the outer frame. The magnetic path is laminated to reduce eddy currents, reducing losses and heating.
- A set of insulated electrical windings, which are placed inside the slots of the laminated stator. The cross-sectional area of these windings must be large enough for the power rating of the motor. For a 3-phase motor, 3 sets of windings are required, one for each



phase connected in either star or delta. Fig 1 shows the cross sectional view of an induction motor. Details of construction of stator are shown in Figs 4-6.

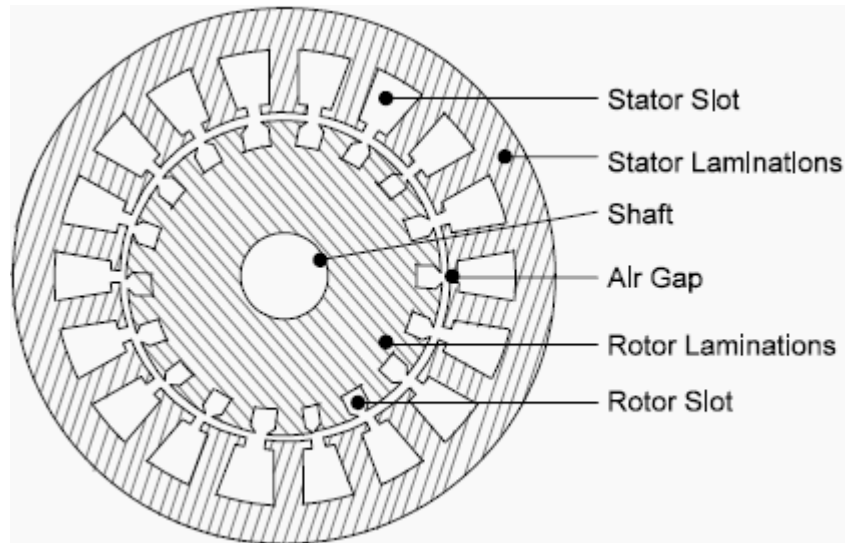

Fig 1: Stator and rotor laminations

### The rotor

Rotor is the rotating part of the induction motor. The rotor also consists of a set of slotted silicon steel laminations pressed together to form of a cylindrical magnetic circuit and the electrical circuit. The electrical circuit of the rotor is of the following nature

Squirrel cage rotor consists of a set of copper or aluminum bars installed into the slots, which are connected to an end-ring at each end of the rotor. The construction of this type of rotor along with windings resembles a 'squirrel cage'. Aluminum rotor bars are usually die-cast into the rotor slots, which results in a very rugged construction. Even though the aluminum rotor bars are in direct contact with the steel laminations, practically all the rotor current flows through the aluminum bars and not in the lamination

Wound rotor consists of three sets of insulated windings with connections brought out to three slip rings mounted on one end of the shaft. The external connections to the rotor are made through brushes onto the slip rings as shown in fig 7. Due to the presence of slip rings such type of motors are called slip ring motors. Sectional view of the full induction motor is shown in Fig. 8

Some more parts, which are required to complete the constructional details of an induction motor, are:

- Two end-flanges to support the two bearings, one at the driving-end and the other at the non driving-end, where the driving end will have the shaft extension.
- Two sets of bearings to support the rotating shaft,
- Steel shaft for transmitting the mechanical power to the load

- Cooling fan located at the non driving end to provide forced cooling for the stator and rotor
- Terminal box on top of the yoke or on side to receive the external electrical connections

Figure 2 to show the constructional details of the different parts of induction motor.



Fig. 2 Stator laminations

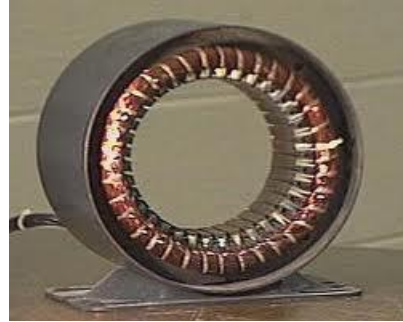

Fig. 3 stator core with smooth yoke



Fig.4 Stator with ribbed yoke



Fig 5. Squirrel cage rotor

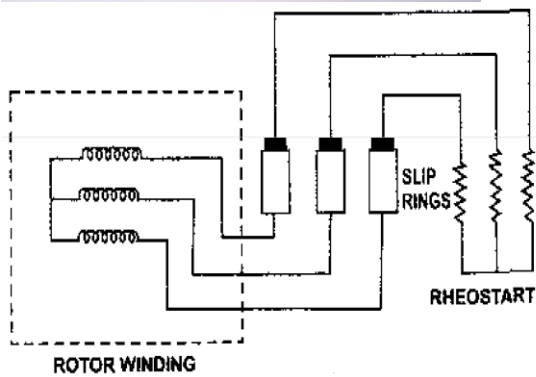

Fig. 6. Slip ring rotor

Fig 7. Connection to slip rings



Fig. 8 Cut sectional view of the induction motor.

### Introduction to Design

The main purpose of designing an induction motor is to obtain the complete physical dimensions of all the parts of the machine as mentioned below to satisfy the customer specifications. The following design details are required.

1. The main dimensions of the stator.
2. Details of stator windings.
3. Design details of rotor and its windings
4. Performance characteristics.

In order to get the above design details the designer needs the customer specifications

Rated output power, rated voltage, number of phases, speed, frequency, connection of stator winding, type of rotor winding, working conditions, shaft extension details etc.

In addition to the above the designer must have the details regarding design equations based on which the design procedure is initiated, information regarding the various choice of various parameters, information regarding the availability of different materials and the limiting values of various performance parameters such as iron and copper losses, no load current, power factor, temperature rise and efficiency

**Output Equation:** output equation is the mathematical expression which gives the relation between the various physical and electrical parameters of the electrical machine.

In an induction motor the output equation can be obtained as follows

Consider an 'm' phase machine, with usual notations

Output  $Q$  in kW = Input  $\times$  efficiency

Input to motor =  $mV_{ph} I_{ph} \cos \Phi \times 10^{-3}$  kW

For a 3  $\Phi$  machine  $m = 3$

Input to motor =  $3V_{ph} I_{ph} \cos \Phi \times 10^{-3}$  kW

Assuming  $V_{ph} = E_{ph}$ ,  $V_{ph} = E_{ph} = 4.44 f \Phi T_{ph} K_w$

$$= 2.22 f \Phi Z_{ph} K_w$$

$$f = \frac{PN_s}{120} = \frac{Pn_s}{2},$$

$$\text{Output} = 3 \times 2.22 \times P n_s / 2 \times \Phi Z_{ph} K_w I_{ph} \eta \cos \Phi \times 10^{-3} \text{ kW}$$

$$\text{Output} = 1.11 \times P \Phi \times 3 I_{ph} Z_{ph} \times n_s K_w \eta \cos \Phi \times 10^{-3} \text{ kW}$$

$$P \Phi = B_{av} \pi D L, \text{ and } 3 I_{ph} Z_{ph} / \pi D = q$$

$$\text{Output to motor} = 1.11 \times B_{av} \pi D L \times \pi D q \times n_s K_w \eta \cos \Phi \times 10^{-3} \text{ kW}$$

$$Q = (1.11 \pi^2 B_{av} q K_w \eta \cos \Phi \times 10^{-3}) D^2 L n_s \text{ kW}$$

$$Q = (11 B_{av} q K_w \eta \cos \Phi \times 10^{-3}) D^2 L n_s \text{ kW}$$

$$\text{Therefore Output } Q = C_o D^2 L n_s \text{ kW}$$

$$\text{where } C_o = (11 B_{av} q K_w \eta \cos \Phi \times 10^{-3})$$

$V_{ph}$  = phase voltage ;  $I_{ph}$  = phase current

$Z_{ph}$  = no of conductors/phase

$T_{ph}$  = no of turns/phase

$N_s$  = Synchronous speed in rpm

$n_s$  = synchronous speed in rps

$p$  = no of poles,  $q$  = Specific electric loading

$\Phi$  = air gap flux/pole;  $B_{av}$  = Average flux density

$k_w$  = winding factor

$\eta$  = efficiency

$\cos \Phi$  = power factor

$D$  = Diameter of the stator,

$L$  = Gross core length

$C_o$  = Output coefficient

Fig.9 shows the details of main dimensions of the of an induction motor.

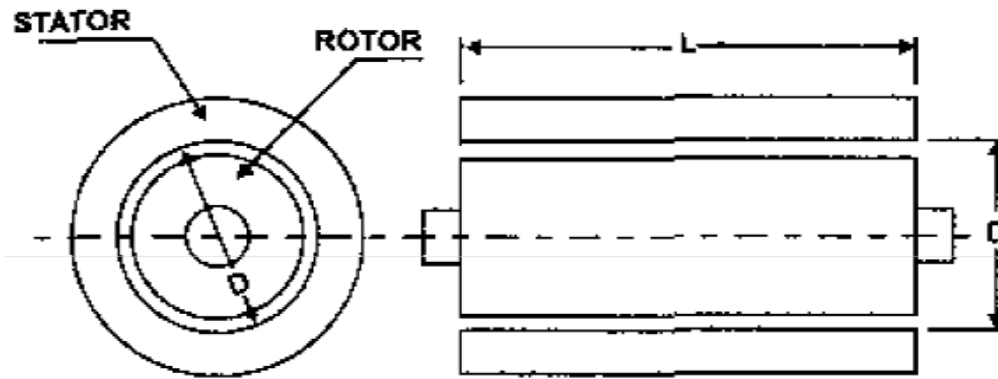

Fig 9. Main dimensions D and L

### Choice of Specific loadings

#### Specific Magnetic loading or Air gap flux density

Iron losses largely depend upon air gap flux density

Limitations :

Flux density in teeth < 1.8 Tesla

Flux density in core 1.3 – 1.5 Tesla

Advantages of Higher value of  $B_{av}$

- Size of the machine reduced
- Cost of the machine decreases
- Overload capacity increases

For 50 Hz machine, 0.35 – 0.6 Tesla. The suitable values of  $B_{av}$  can be selected from design data hand book.

#### Specific Electric loading

Total armature ampere conductor over the periphery

Advantages of Higher value of  $q$

- Reduced size
- Reduced cost

Disadvantages of Higher value of  $q$

- Higher amount of copper
- More copper losses
- Increased temperature rise
- Lower overload capacity

Normal range 10000 ac/m – 450000 ac/m. The suitable values of  $q$  can be selected from design data hand book.

### Choice of power factor and efficiency

Choice of power factor and efficiency under full load conditions will increase with increase in rating of the machine. Percentage magnetizing current and losses will be lower for a larger machine than that of a smaller machine. Further the power factor and efficiency will be higher for a high speed machine than the same rated low speed machine because of better cooling conditions. Taking into considerations all these factors the above parameters will vary in a range based on the output of the machine. Similar to  $B_{av}$  and  $q$ , efficiency and power factor values can be selected from Design data hand book.

### Separation of D and L

The output equation gives the relation between  $D^2L$  product and output of the machine. To separate D and L for this product a relation has to be assumed or established. Following are the various design considerations based on which a suitable ratio between gross length and pole pitch can be assumed.

i. To obtain minimum over all cost	1.5 to 2.0
ii. To obtain good efficiency	1.4 to 1.6
iii. To obtain good over all design	1.0 to 1.1
iv. To obtain good power factor	1.0 to 1.3

As power factor plays a very important role the performance of induction motors it is advisable to design an induction motor for best power factor unless specified. Hence to obtain the best power factor the following relation will be usually assumed for separation of D and L.

$$\text{Pole pitch/ Core length} = 0.18/\text{pole pitch}$$

or 
$$(\pi D/p) / L = 0.18 / (\pi D/p)$$

i.e 
$$D = 0.135P\sqrt{L}$$
 where D and L are in meter.

Using above relation  $D$  and  $L$  can be separated from  $D^2L$  product. However the obtained values of  $D$  and  $L$  have to satisfy the condition imposed on the value of peripheral speed.

### Peripheral Speed

For the normal design of induction motors the calculated diameter of the motor should be such that the peripheral speed must be below 30 m/s. In case of specially designed rotor the peripheral speed can be 60 m/s.

### Design of Stator

Stator of an induction motor consists of stator core and stator slots.

Stator slots: in general two types of stator slots are employed in induction motors viz, open slots and semiclosed slots. Operating performance of the induction motors depends upon the shape of the slots and hence it is important to select suitable slot for the stator slots.

- (i) Open slots: In this type of slots the slot opening will be equal to that of the width of the slots as shown in Fig 10. In such type of slots assembly and repair of winding are easy. However such slots will lead to higher air gap contraction factor and hence poor power factor. Hence these types of slots are rarely used in  $3\Phi$  induction motors.
- (ii) Semiclosed slots: In such type of slots, slot opening is much smaller than the width of the slot as shown in Fig 10 and Fig 11. Hence in this type of slots assembly of windings is more difficult and takes more time compared to open slots and hence it is costlier. However the air gap characteristics are better compared to open type slots.
- (iii) Tapered slots: In this type of slots also, opening will be much smaller than the slot width. However the slot width will be varying from top of the slot to bottom of the slot with minimum width at the bottom as shown in Fig. 10.

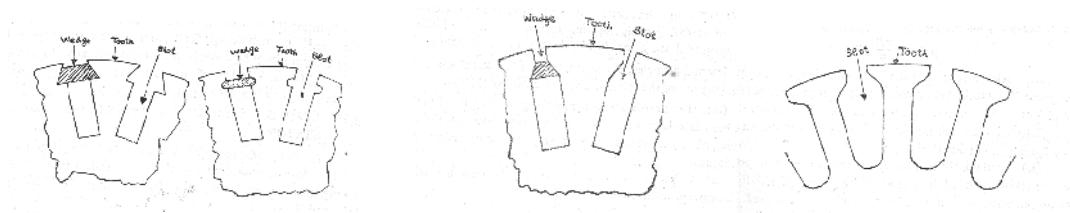

(i) Open type

(ii) Semiclosed type

(iii) Tapered type

Fig. 10 Different types type slots



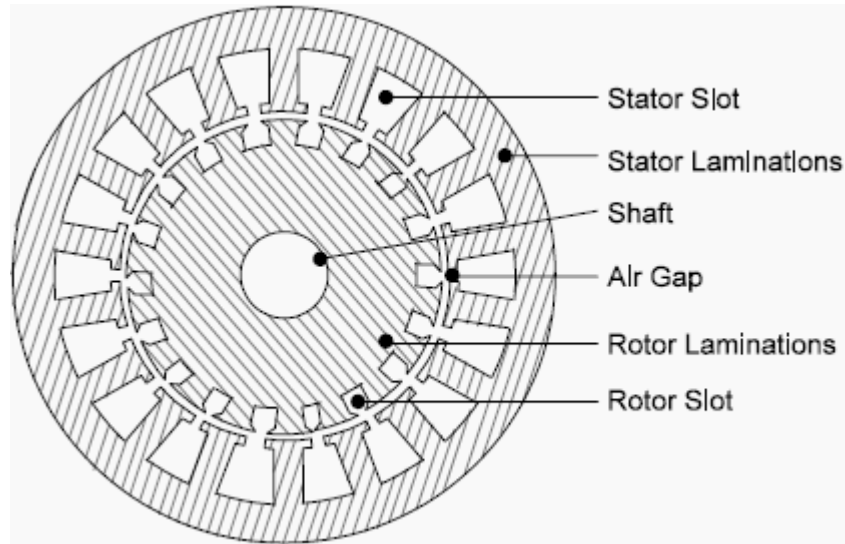

Fig. 11 Semiclosed slots

**Selection of number of stator slots:** Number of stator slots must be properly selected at the design stage as such this number affects the weight, cost and operating characteristics of the motor. Though there are no rules for selecting the number of stator slots considering the advantages and disadvantages of selecting higher number slots comprise has to be set for selecting the number of slots. Following are the advantages and disadvantages of selecting higher number of slots.

Advantages :(i) Reduced leakage reactance.

(ii) Reduced tooth pulsation losses.

(iii) Higher over load capacity.

Disadvantages:

(i) Increased cost

(ii) Increased weight

(iii) Increased magnetizing current

(iv) Increased iron losses

(v) Poor cooling

(vi) Increased temperature rise

(vii) Reduction in efficiency

Based on the above comprise is made and the number of slots/pole/phase may be selected as three or more for integral slot winding. However for fractional slot windings number of

slots/pole/phase may be selected as 3.5. So selected number of slots should satisfy the consideration of stator slot pitch at the air gap surface, which should be between 1.5 to 2.5 cm.

Stator slot pitch at the air gap surface =  $\tau_{ss} = \pi D / S_{ss}$  where  $S_{ss}$  is the number of stator slots

### Turns per phase

EMF equation of an induction motor is given by  $E_{ph} = 4.44f\Phi T_{ph}k_w$

Hence turns per phase can be obtained from emf equation  $T_{ph} = E_{ph} / 4.44f\Phi k_w$

Generally the induced emf can be assumed to be equal to the applied voltage per phase

Flux/pole,  $\Phi = B_{av} \times \pi DL / P$ ,

winding factor  $k_w$  may be assumed as 0.955 for full pitch distributed winding unless otherwise specified.

Number conductors /phase,  $Z_{ph} = 2 \times T_{ph}$ , and hence Total number of stator conductors  $Z = 6 T_{ph}$  and conductors /slot  $Z_s = Z / S_s$  or  $6 T_{ph} / S_s$ , where  $Z_s$  is an integer for single layer winding and even number for double layer winding.

**Conductor cross section:** Area of cross section of stator conductors can be estimated from the stator current per phase and suitably assumed value of current density for the stator windings.

Sectional area of the stator conductor  $a_s = I_s / \delta_s$  where  $\delta_s$  is the current density in stator windings

$$\text{Stator current per phase } I_s = Q / (3V_{ph} \cos \phi)$$

A suitable value of current density has to be assumed considering the advantages and disadvantages.

Advantages of higher value of current density:

- (i) reduction in cross section
- (ii) reduction in weight
- (iii) reduction in cost

Disadvantages of higher value of current density

- (i) increase in resistance
- (ii) increase in cu loss
- (iii) increase in temperature rise
- (iv) reduction in efficiency

Hence higher value is assumed for low voltage machines and small machines. Usual value of current density for stator windings is 3 to 5 amps.

Based on the sectional area shape and size of the conductor can be decided. If the sectional area of the conductors is below  $5 \text{ mm}^2$  then usually circular conductors are employed. If it is above  $5 \text{ mm}^2$  then rectangular conductors will be employed. Standard bare size of round and rectangular conductors can be selected by referring the tables of conductors given in Design data Hand book. In case of rectangular conductors width to thickness ratio must be between 2.5 to 3.5.

**Area of stator slot:** Slot area is occupied by the conductors and the insulation. Out of which almost more than 25 % is the insulation. Once the number of conductors per slot is decided approximate area of the slot can be estimated.

Slot space factor = Copper area in the slot /Area of each slot

This slot space factor so obtained will be between 0.25 and 0.4. The detailed dimension of the slot can be estimated as follows.

**Size of the slot:** Normally different types of slots are employed for carrying stator windings of induction motors. Generally full pitched double layer windings are employed for stator windings. For double layer windings the conductor per slot will be even. These conductors are suitably arranged along the depth and width of the winding. Stator slots should not be too wide, leading to thin tooth width, which makes the tooth mechanically weak and maximum flux density may exceed the permissible limit. Hence slot width should be so selected such that the flux density in tooth is between 1.6 to 1.8 Tesla. Further the slots should not be too deep also other wise the leakage reactance increases. As a guideline the ratio of slot depth to slot width may assumed as 3 to 5. Slot insulation details along the conductors are shown in Fig. 12.

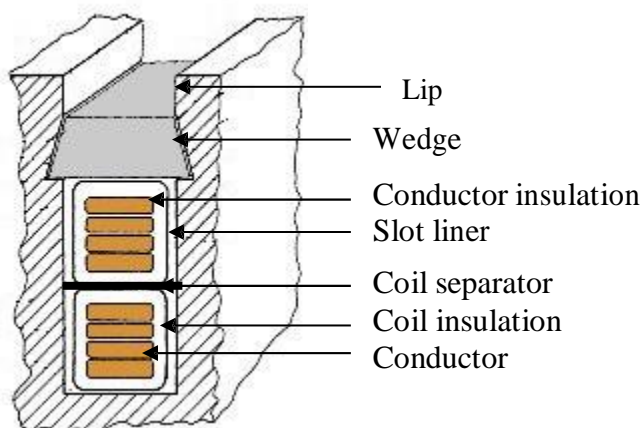

Fig. 12 Slot insulation detail with conductor

Proper slot insulation as per the voltage rating of the machine has to be provided before inserting the insulated coil in the slots. This slot insulation is called the slot liner, thickness of which may be taken as 0.5 mm to 0.7 mm. Suitable thickness of insulation called coil separator separates the two layers of coils. Thickness of coil separator is 0.5 mm to 0.7 mm for low voltage machines and 0.8 mm to 1.2 mm for high voltage machines. Wedge of suitable thickness (3.5 mm to 5 mm) is placed at the top of the slot to hold the coils in position. Lip of the slot is taken 1.0 to 2.0 mm. Figure 13 shows the coils placed in slots.

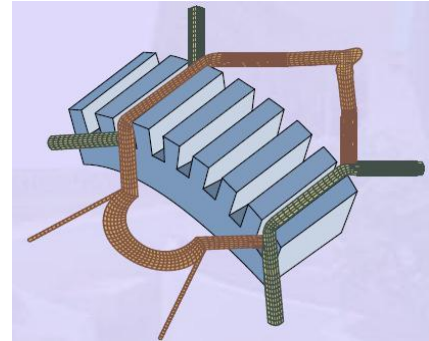

Fig 13. Stator coils, placed in slots

#### Length of the mean Turn:

Length of the mean turn is calculated using an empirical formula  $l_{mt} = 2L + 2.3 \tau_p + 0.24$  where  $L$  is the gross length of the stator and  $\tau_p$  is pole pitch in meter.

**Resistance of stator winding:** Resistance of the stator winding per phase is calculated using the formula  $= (0.021 \times l_{mt} \times T_{ph}) / a_s$  where  $l_{mt}$  is in meter and  $a_s$  is in  $\text{mm}^2$ . Using so calculated resistance of stator winding copper losses in stator winding can be calculated as

$$\text{Total copper losses in stator winding} = 3 (I_s)^2 r_s$$

**Flux density in stator tooth:** Knowing the dimensions of stator slot pitch, width of the slot and width of the stator tooth flux density in the stator tooth can be calculated. The flux density in the stator tooth is limited to 1.8 Tesla. As the stator tooth is tapering towards the bottom, the flux density is calculated at  $1/3^{\text{rd}}$  height from the narrow end of the tooth. The flux density at the  $1/3^{\text{rd}}$  height from the narrow end of the tooth can be calculated as follows.

$$\text{Diameter at } 1/3^{\text{rd}} \text{ height from narrow end } D' = D + 1/3 \times h_{ts} \times 2$$

$$\text{Slot pitch at } 1/3^{\text{rd}} \text{ height} = \tau'_s = \pi \times D' / S_s$$

$$\text{Tooth width at this section} = b'_t = \tau'_s - b_s$$

$$\text{Area of one stator tooth} = a'_t = b'_t \times l_i$$

$$\text{Area of all the stator tooth per pole } A'_t = b'_t \times l_i \times \text{number of teeth per pole}$$

$$\text{Mean flux density in stator teeth } B'_t = \Phi / A'_t$$

Maximum flux density in the stator teeth may be taken to be less than 1.5 times the above value.

**Depth of stator core below the slots:** There will be certain solid portion below the slots in the stator which is called the depth of the stator core. This depth of the stator core can be calculated by assuming suitable value for the flux density  $B_c$  in the stator core. Generally the flux density in the stator core may be assumed varying between 1.2 to 1.4 Tesla. Depth of the stator core can be calculated as follows.

$$\text{Flux in the stator core section } \Phi_c = \frac{1}{2} \Phi$$

$$\text{Area of stator core } A_c = \Phi / 2B_c$$

$$\text{Area of stator core } A_c = L_i \times d_{cs}$$

$$\text{Hence, depth of the core } = A_c / L_i$$

Using the design data obtained so far outer diameter of the stator core can be calculated as

$$D_o = D + 2h_{ss} = 2 d_{cs} \text{ where } h_{ss} \text{ is the height of the stator slot.}$$

### Problems

**Ex. 1.** Obtain the following design information for the stator of a 30 kW, 440 V, 3 $\Phi$ , 6 pole, 50 Hz delta connected, squirrel cage induction motor, (i) Main dimension of the stator, (ii) No. of turns/phase (iii) No. of stator slots, (iv) No. of conductors per slot. Assume suitable values for the missing design data.

**Soln:** Various missing data are assumed from referring to Design data Hand Book or tables in Text Book considering the size, economics and performance

Specific Magnetic loading,  $B_{av} = 0.48$  Tesla

Specific Electric loading,  $q = 26000$  ac/m

Full load efficiency,  $\eta = 0.88$

Full load power factor  $\cos\Phi = 0.86$

Winding factor  $K_w = 0.955$

(i) Main dimensions

We have from output equation:

$$D^2L = Q / (C_o n_s) \text{ m}^3$$

$$\begin{aligned} C_o &= 11 B_{av} q K_w \eta \cos\Phi \times 10^{-3} \\ &= 11 \times 0.48 \times 26000 \times 0.955 \times 0.88 \times 0.86 \times 10^{-3} \\ &= 99.2 \end{aligned}$$

and  $n_s = 16.67$  rps

$$\begin{aligned} D^2L &= 30 / (99.2 \times 16.67) \\ &= 0.0182 \text{ m}^3 \end{aligned}$$

Designing the m/c for best power factor

$$\begin{aligned} D &= 0.135P\sqrt{L} \\ &= 0.135 \times 6\sqrt{L} \end{aligned}$$

Solving for D and L  $D = 0.33 \text{ m}$  and  $L = 0.17 \text{ m}$

(ii) No. of stator turns

$$\Phi = (\pi DL/p) B_{av} = (\pi \times 0.33 \times 0.17 / 6) \times 0.48 = 0.141 \text{ wb}$$

Assuming  $E_{ph} = V_{ph} = 440$  volts

$$\begin{aligned} T_{ph} &= E_{ph} / 4.44f\Phi k_w = 440 / (4.44 \times 50 \times 0.0141 \times 0.955) \\ &= 148 \end{aligned}$$

(iii) No. of stator slots

Assuming no of slot/pole/phase = 3

$$\text{Total no. of slots} = 3 \times 3 \times 6 = 54$$

(iv) No of conductors /slot

$$\text{Total no of conductors} = 148 \times 2 = 296$$

$$\text{No. of conductors /slot} = 296/54 = 5.5$$

Assuming 76 conductors/ slot

$$\text{Total no. of conductors} = 54 \times 6 = 324$$

$$\text{Revised no. of turns/phase} = 162$$

**Ex. 2** A 15 kW 440m volts 4 pole, 50 Hz, 3 phase induction motor is built with a stator bore of 0.25 m and a core length of 0.16 m. The specific electric loading is 23000 ac/m. Using data of this machine determine the core dimensions, number of slots and number of stator conductors for a 11kW, 460 volts, 6 pole, 50 Hz motor. Assume full load efficiency of 84 % and power factor of 0.82. The winding factor is 0.955.

**Soln:** For 15 kW motor:

$$\text{Motor Input} = 15 / 0.84 = 17.857 \text{ kW} ; \quad \text{Synchronous speed } n_s = 120 \times 50 / (4 \times 60) = 25 \text{ rps};$$

$$\text{we have output coefficient } C_o = \text{out put} / D^2 L n_s = 15 / (0.25^2 \times 0.16 \times 25) = 60$$

$$\begin{aligned} \text{we have } C_o &= 11 B_{av} q K_w \eta \cos\Phi \times 10^{-3} = 11 \times B_{av} \times 23000 \times 0.955 \times 0.84 \times 0.82 \times 10^{-3} \\ &= 166.42 B_{av} \end{aligned}$$

$$\text{Hence } B_{av} = 60/166.42 = 0.36 \text{ Tesla}$$

$$\text{Pole pitch } \tau_p = \pi D/p = \pi \times 0.25/4 = 0.196 \text{ m}; \quad L/\tau_p = 0.815$$

For 11kW motor: the design data from 15 kW machine has to be taken

$$\text{So } B_{av} = 0.36 \text{ Tesla}; \quad q = 23000 \text{ ac/m}; \quad L/\tau_p = 0.815; \quad \text{and } C_o = 60$$

$$\text{Synchronous speed} = 120 \times 50 / (6 \times 60) = 16.667 \text{ rps};$$

$$\begin{aligned} D^2 L &= Q / (C_o n_s) \text{ m}^3 \\ &= 11 / (60 \times 16.667) = 0.01099 \text{ m}^3 \end{aligned}$$

$$L / (\pi D / p) = 0.815, \quad \text{So } L/D = 0.815 \times \pi / 6 = 0.427 \quad \text{or } L = 0.427 D$$

Substituting this value in  $D^2 L$  product and solving for D and L

$$0.427 D^3 = 0.01099 \quad \text{hence } D = 0.30 \text{ m and } L = 0.125 \text{ m}$$

Number of slots: Considering the slot pitch at the air gap between 1.5 cm and 2.5 cm

For slot pitch 2.5 cm  $S_s = \pi \times 30 / 2.5 = 37$  Hence number of slots must be between 37 & 63

Assuming no. of stator slots /pole/phase = 3,  $S_s = 6 \times 3 \times 3 = 54$

Flux per pole  $= B_{av} \times D \times L / p = 0.36 \times \pi \times 0.3 \times 0.125 / 6 = 7.07 \times 10^{-3}$  wb

Assuming star delta connection for the machine, under running condition using Delta connection

Stator turns per phase  $T_{ph} = E_{ph} / (4.44 f K_w) = 460 / (4.44 \times 50 \times 7.07 \times 10^{-3} \times 0.955) = 307$

Number conductors/phase =  $307 \times 2$ ,

Total number of stator conductors =  $307 \times 2 \times 3 = 1872$

Number of conductors per slot =  $1872 / 54 = 34.1 \approx 34$

Hence total number of conductor =  $34 \times 54 = 1836$ .

**Ex. 3** Determine main dimensions, turns/phase, number of slots, conductor size and area of slot of 250 HP, 3 phase, 50 Hz, 400 volts, 1410 rpm, slip ring induction motor. Assume  $B_{av} = 0.5$  wb/m<sup>2</sup>,  $q = 30000$  ac/m, efficiency = 90 % and power factor = 0.9, winding factor = 0.955, current density =  $3.5$  a/mm<sup>2</sup>, slot space factor = 0.4 and the ratio of core length to pole pitch is 1.2. the machine is delta connected. (July 2007)

**Soln.**

**Ex. 4.** During the preliminary design of a 270 kW, 3600 volts, 3 phase, 8 pole 50 Hz slip ring induction motor the following design data have been obtained.

Gross length of the stator core = 0.38 m, Internal diameter of the stator = 0.67 m, outer diameter of the stator = 0.86 m, No. of stator slots = 96, No. of conductors /slot = 12, Based on the above information determine the following design data for the motor. (i) Flux per pole (ii) Gap density (iii) Conductor size (iv) size of the slot (v) copper losses (vi) flux density in stator teeth (vii) flux density in stator core.

**Soln.** (i) Flux per pole

Number of slots per phase  $96 / 3 = 32$

Number of turns per phase  $T_{ph} = 32 \times 12 / 2 = 192$ ,

Assuming full pitched coils,  $k_w = 0.955$ ,  $E_{ph} = V_{ph}$  and star connected stator winding,



We have  $E_{ph} = 4.44f\Phi T_{ph}k_w$ , ie

$$\Phi = E_{ph} / (4.44fT_{ph}k_w) = 2078 / (4.44 \times 50 \times 192 \times 0.955) = 0.051 \text{ wb}$$

(ii) Gap flux density  $A_g = \pi DL/p = \pi \times 0.67 \times 0.38 / 8 = 0.1 \text{ m}^2$

$$B_g = \Phi / A_g = 0.051 / 0.1 = 0.51 \text{ Tesla}$$

(iii) Conductor size

Assuming an efficiency of 91% and a full load power factor of 0.89

$$\text{Input power to the motor} = 270 \times 10^3 / 0.91 = 296703 \text{ w}$$

$$\text{Full load current per phase} = 296703 / (3 \times 2078 \times 0.89) = 53.47 \text{ amps}$$

Assuming a current density of 4.1 amp/mm<sup>2</sup>, area of cross section of the conductor = 53.47 / 4.1 = 13.04 mm<sup>2</sup> as the conductor section is > 5 mm<sup>2</sup> rectangular conductor is selected. Standard size of the conductor selected satisfying the requirements is 2.5 mm x 5.5 mm.

Thus sectional area of the conductor 13.2 mm<sup>2</sup>

Size of the conductor with insulation thickness of 0.2 mm is 2.9 mm x 5.9 mm

(iv) size of the slot

12 conductors per slot are arranged in two layers with 6 conductors in each layer. Six conductors in each layer are arranged as 2 conductors depth wise and 3 conductors width wise. With this arrangement the width and depth of the slot can be estimated as follows.

(a) Width of the slot

Space occupied by insulated conductor, 3 x 2.9	8.7 mm
Coil insulation, 2 x 1.0	2.0 mm
Slot liner, 2 x 0.2	0.4 mm
Clearance	0.9 mm
Total width of the slot	<hr/> 12.0 mm

(b) Depth of the slot

Space occupied by insulated conductor, 4 x 5.9	23.6 mm
Coil insulation, 4 x 1.0	4.0 mm
Slot liner, 3 x 0.2	0.6 mm
Coil separator, 1 x 1.0	0.5 mm
Top liner, 1 x 1.0	0.5 mm
Wedge	3.0 mm
Lip	1.5 mm
Clearance	1.3 mm
<b>Total height of the slot</b>	<b>35.0 mm</b>

Thus the dimension of the slot 12.0 mm x 35.0 mm

(v) Copper losses in stator winding

Length of the mean turn,  $l_{mt} = 2L + 2.3 \tau_p + 0.24 = 2 \times 0.38 + 2.3 \times \pi \times 0.67/8 + 0.24 = 1.6 \text{ m}$

Resistance per phase =  $(0.021 \times l_{mt} \times T_{ph}) / a_s = 0.021 \times 1.6 \times 192 / 13.2 = 0.49 \text{ ohm.}$

Total copper losses =  $3I_s^2 r_s = 3 \times 53.47^2 \times 0.49 = 4203 \text{ watts}$

(vi) Flux density in stator tooth

Diameter at  $1/3^{\text{rd}}$  height,  $D' = D + 1/3 \times h_{ts} \times 2 = 0.67 + 1/3 \times 0.035 \times 2 = 0.693 \text{ m}$

Slot pitch at  $1/3^{\text{rd}}$  height =  $\tau'_s = \pi \times D' / S_s = \pi \times 0.693 / 96 = 0.02268 \text{ m}$

Tooth width at this section =  $b'_t = \tau'_s - b_s = 0.02268 - 0.012 = 0.0168 \text{ m}$

assuming 3 ventilating ducts with 1cm width and iron space factor of 0.95

Iron length  $l_i = (0.38 - 3 \times 0.01) 0.95 = 0.3325 \text{ m}$

Area of the stator tooth per pole  $A'_t = b'_t \times l_i \times \text{number of teeth per pole}$

$$= b'_t \times l_i \times S_s / p = 0.0168 \times 0.3325 \times 96 / 8$$

$$= 0.04261 \text{ m}^2$$

Mean flux density in stator teeth  $B'_t = \Phi / A'_t = 0.051 / 0.04261 = 1.10$  Tesla

Maximum flux density in stator tooth  $= 1.5 \times 1.10 = 1.65$  Tesla

(vii) Flux density in stator core

Depth of the stator core  $d_{cs} = \frac{1}{2} (D_o - D - 2 h_{ss}) = \frac{1}{2} (0.86 - 0.67 - 2 \times 0.035) = 0.06$  m

Area of stator core  $A_c = L_i \times d_{cs} = 0.3325 \times 0.06 = 0.01995$  m<sup>2</sup>

Flux in stator core  $= \frac{1}{2} \times \Phi = \frac{1}{2} \times 0.051 = 0.0255$  wb

Flux density in stator core,  $B_c = \Phi_c / A_c = 0.0255 / 0.01995 = 1.28$  Tesla

### Design of Rotor:

There are two types of rotor construction. One is the squirrel cage rotor and the other is the slip ring rotor. Most of the induction motor are squirrel cage type. These are having the advantage of rugged and simple in construction and comparatively cheaper. However they have the disadvantage of lower starting torque. In this type, the rotor consists of bars of copper or aluminum accommodated in rotor slots. In case slip ring induction motors the rotor complex in construction and costlier with the advantage that they have the better starting torque. This type of rotor consists of star connected distributed three phase windings.

Between stator and rotor is the air gap which is a very critical part. The performance parameters of the motor like magnetizing current, power factor, over load capacity, cooling and noise are affected by length of the air gap. Hence length of the air gap is selected considering the advantages and disadvantages of larger air gap length.

Advantages:

- (i) Increased overload capacity
- (ii) Increased cooling
- (iii) Reduced unbalanced magnetic pull
- (iv) Reduced in tooth pulsation
- (v) Reduced noise

Disadvantages

- (i) Increased Magnetising current
- (ii) Reduced power factor

Effect of magnetizing current and its effect on the power factor can be understood from the phasor diagram of the induction motor shown in Fig. 14.

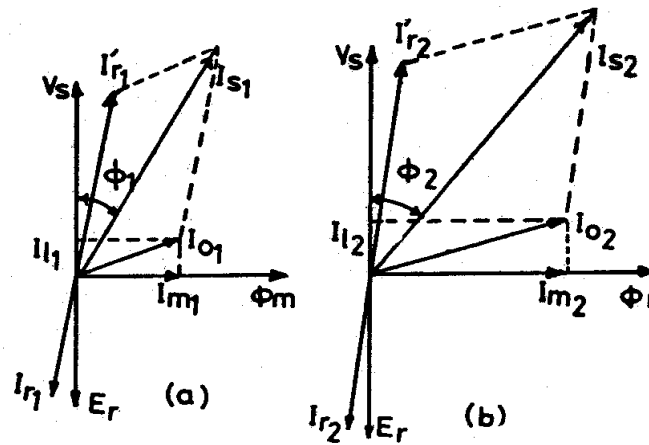

Fig. 14 Phasor diagram of induction motor

Magnetising current and power factor being very important parameters in deciding the performance of induction motors, the induction motors are designed for optimum value of air gap or minimum air gap possible. Hence in designing the length of the air gap following empirical formula is employed.

$$\text{Air gap length } l_g = 0.2 + 2\sqrt{DL} \text{ mm}$$

The following Fig. 15 show the different types of rotor construction.



Fig. 15 Squirrel cage rotor



Slip ring rotor

**Number of slots:** Proper numbers of rotor slots are to be selected in relation to number of stator slots otherwise undesirable effects will be found at the starting of the motor. Cogging and Crawling are the two phenomena which are observed due to wrong combination of number of rotor and stator slots. In addition, induction motor may develop unpredictable hooks and cusps in torque speed characteristics or the motor may run with lot of noise. Let us discuss Cogging and Crawling phenomena in induction motors.

**Crawling:** The rotating magnetic field produced in the air gap of the will be usually nonsinusoidal and generally contains odd harmonics of the order 3<sup>rd</sup>, 5<sup>th</sup> and 7<sup>th</sup>. The third harmonic flux will produce the three times the magnetic poles compared to that of the fundamental. Similarly the 5<sup>th</sup> and 7<sup>th</sup> harmonics will produce the poles five and seven times the fundamental respectively. The presence of harmonics in the flux wave affects the torque speed characteristics. The Fig. 16 below shows the effect of 7<sup>th</sup> harmonics on the torque speed characteristics of three phase induction motor. The motor with presence of 7<sup>th</sup> harmonics is to have a tendency to run the motor at one seventh of its normal speed. The 7<sup>th</sup> harmonics will produce a dip in torque speed characteristics at one seventh of its normal speed as shown in torque speed characteristics.

**Cogging:** In some cases where in the number of rotor slots are not proper in relation to number of stator slots the machine refuses to run and remains stationary. Under such conditions there will be a locking tendency between the rotor and stator. Such a phenomenon is called cogging.

Hence in order to avoid such bad effects a proper number of rotor slots are to be selected in relation to number of stator slots. In addition rotor slots will be skewed by one slot pitch to minimize the tendency of cogging, torque defects like synchronous hooks and cusps and noisy operation while running. Effect of skewing will slightly increase the rotor resistance and increases the starting torque. However this will increase the leakage reactance and hence reduces the starting current and power factor.

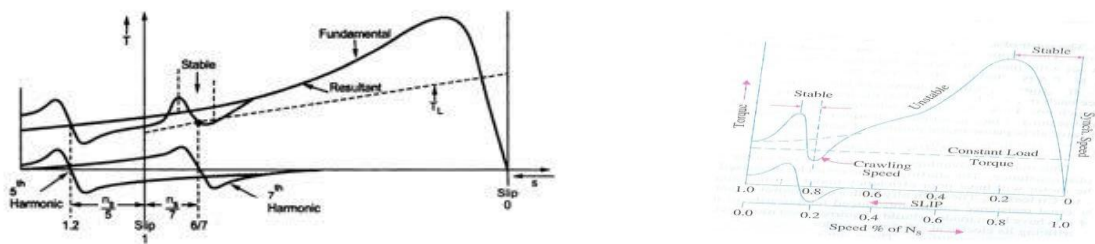

Fig 16 Torque speed characteristics

**Selection of number of rotor slots:** The number of rotor slots may be selected using the following guide lines.

- (i) To avoid cogging and crawling: (a)  $S_s \neq S_r$  (b)  $S_s - S_r \neq \pm 3P$
- (ii) To avoid synchronous hooks and cusps in torque speed characteristics  $\neq \pm P, \pm 2P, \pm 5P$ .
- (iii) To noisy operation  $S_s - S_r \neq \pm 1, \pm 2, (\pm P \pm 1), (\pm P \pm 2)$

**Rotor Bar Current:** Bar current in the rotor of a squirrel cage induction motor may be determined by comparing the mmf developed in rotor and stator.

Hence the current per rotor bar is given by  $I_b = (K_{ws} \times S_s \times Z'_s) \times I'_r / (K_{wr} \times S_r \times Z'_r)$  ;

where  $K_{ws}$  – winding factor for the stator,  $S_s$  – number of stator slots,  $Z'_s$  – number of conductors / stator slots,  $K_{wr}$  – winding factor for the rotor,  $S_r$  – number of rotor slots,  $Z'_r$  – number of conductors / rotor slots and  $I'_r$  – equivalent rotor current in terms of stator current and is given by  $I'_r = 0.85 I_s$  where  $I_s$  is stator current per phase.

**Cross sectional area of Rotor bar:** Sectional area of the rotor conductor can be calculated by rotor bar current and assumed value of current density for rotor bars. As cooling conditions are better for the rotor than the stator higher current density can be assumed. Higher current density will lead to reduced sectional area and hence increased resistance, rotor cu losses and reduced efficiency. With increased rotor resistance starting torque will increase. As a guide line the rotor bar current density can be assumed between 4 to 7 Amp/mm<sup>2</sup> or may be selected from design data Hand Book.

Hence sectional area of the rotor bars can be calculated as  $A_b = I_b / \delta_b \text{ mm}^2$ . Once the cross sectional area is known the size of the conductor may be selected from standard table given in data hand book.

**Shape and Size of the Rotor slots:** Generally semiclosed slots or closed slots with very small or narrow openings are employed for the rotor slots. In case of fully closed slots the rotor bars are force fit into the slots from the sides of the rotor. The rotors with closed slots are giving better performance to the motor in the following way. (i) As the rotor is closed the rotor surface is smooth at the air gap and hence the motor draws lower magnetizing current. (ii) reduced noise as the air gap characteristics are better (iii) increased leakage reactance and (iv) reduced starting current. (v) Over load capacity is reduced (vi) Undesirable and complex air gap characteristics. From the above it can be concluded that semiclosed slots are more suitable and hence are employed in rotors.

**Copper loss in rotor bars:** Knowing the length of the rotor bars and resistance of the rotor bars cu losses in the rotor bars can be calculated.

Length of rotor bar  $l_b = L + \text{allowance for skewing}$

Rotor bar resistance =  $0.021 \times l_b / A_b$

Copper loss in rotor bars =  $I_b^2 \times r_b \times \text{number of rotor bars}$ .

**End Ring Current:** All the rotor bars are short circuited by connecting them to the end rings at both the end rings. The rotating magnetic field produced will induce an emf in the rotor bars which will be sinusoidal over one pole pitch. As the rotor is a short circuited body, there will be current flow because of this emf induced. The distribution of current and end rings are as shown in Fig. 17 below. Referring to the figure considering the bars under one pole pitch, half

of the number of bars and the end ring carry the current in one direction and the other half in the opposite direction. Thus the maximum end ring current may be taken as the sum of the average current in half of the number of bars under one pole.

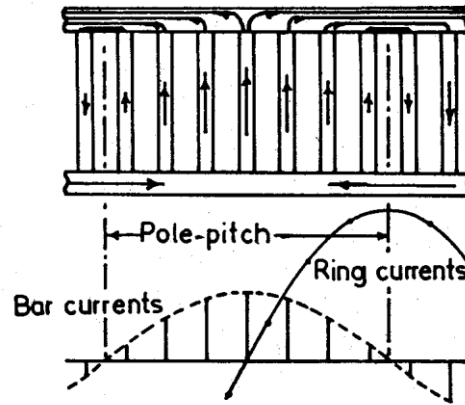

Fig. 17 currents in cage rotor bars and end rings

Maximum end ring current  $I_e(\max) = \frac{1}{2} (\text{Number rotor bars} / \text{pole}) I_b(\text{av})$

$$= \frac{1}{2} \times S_r/P \times I_b/1.11$$

Hence rms value of  $I_e = 1/2\sqrt{2} \times S_r/P \times I_b/1.11$

$$= 1/\pi \times S_r/P \times I_b/1.11$$

**Area of end ring:** Knowing the end ring current and assuming suitable value for the current density in the end rings cross section for the end ring can be calculated as

Area of each end ring  $A_e = I_e / \delta_e \text{ mm}^2$ ,  
current density in the end ring may be assume as 4.5 to 7.5 amp/mm<sup>2</sup>.

**Copper loss in End Rings:** Mean diameter of the end ring ( $D_{me}$ ) is assumed as 4 to 6 cms less than that of the rotor. Mean length of the current path in end ring can be calculated as  $l_{me} = \pi D_{me}$ . The resistance of the end ring can be calculated as

$$r_e = 0.021 \times l_{me} / A_e$$

$$\text{Total copper loss in end rings} = 2 \times I_e^2 \times r_e$$

**Equivalent Rotor Resistance:** Knowing the total copper losses in the rotor circuit and the equivalent rotor current equivalent rotor resistance can be calculated as follows.

$$\text{Equivalent rotor resistance } r'_r = \text{Total rotor copper loss} / 3 \times (I_r')^2$$

**Design of wound Rotor:** These are the types of induction motors where in rotor also carries distributed star connected 3 phase winding. At one end of the rotor there are three slip rings mounted on the shaft. Three ends of the winding are connected to the slip rings. External resistances can be connected to these slip rings at starting, which will be inserted in series with the windings which will help in increasing the torque at starting. Such type of induction motors are employed where high starting torque is required.

**Number of rotor slots:** As mentioned earlier the number of rotor slots should never be equal to number of stator slots. Generally for wound rotor motors a suitable value is assumed for number of rotor slots per pole per phase, and then total number of rotor slots are calculated. So selected number of slots should be such that tooth width must satisfy the flux density limitation. Semiclosed slots are used for rotor slots.

**Number of rotor Turns:** Number of rotor turns are decided based on the safety consideration of the personal working with the induction motors. The voltage between the slip rings on open circuit must be limited to safety values. In general the voltage between the slip rings for low and medium voltage machines must be limited to 400 volts. For motors with higher voltage ratings and large size motors this voltage must be limited to 1000 volts. Based on the assumed voltage between the slip rings comparing the induced voltage ratio in stator and rotor the number of turns on rotor winding can be calculated.

$$\text{Voltage ratio} \quad E_r / E_s = (K_{wr} \times T_r) / (K_{ws} \times T_s)$$

$$\text{Hence rotor turns per phase} \quad T_r = (E_r / E_s) (K_{ws} / K_{wr}) T_s$$

$E_r$  = open circuit rotor voltage/phase

$E_s$  = stator voltage /phase

$K_{ws}$  = winding factor for stator

$K_{wr}$  = winding factor for rotor

$T_s$  = Number of stator turns/phase

### Rotor Current

Rotor current can be calculated by comparing the amp-cond on stator and rotor

$$I_r = (K_{ws} \times S_s \times Z'_s) \times I'_r / (K_{wr} \times S_r \times Z'_r);$$

$K_{ws}$  – winding factor for the stator,

$S_s$  – number of stator slots,

$Z'_s$  – number of conductors / stator slots,

$K_{wr}$  – winding factor for the rotor,

$S_r$  – number of rotor slots,

$Z'_r$  – number of conductors / rotor slots and

$I'_r$  – equivalent rotor current in terms of stator current

$$I'_r = 0.85 I_s \text{ where } I_s \text{ is stator current per phase.}$$



**Area of Rotor Conductor:** Area of rotor conductor can be calculated based on the assumed value for the current density in rotor conductor and calculated rotor current. Current density rotor conductor can be assumed between 4 to 6 Amp/mm<sup>2</sup>

$$A_r = I_r / \delta_r \text{ mm}^2$$

$A_r < 5\text{mm}^2$  use circular conductor, else rectangular conductor, for rectangular conductor width to thickness ratio = 2.5 to 4. Then the standard conductor size can be selected similar to that of stator conductor.

**Size of Rotor slot:** Mostly Semi closed rectangular slots employed for the rotors. Based on conductor size, number conductors per slot and arrangement of conductors similar to that of stator, dimension of rotor slots can be estimated. Size of the slot must be such that the ratio of depth to width of slot must be between 3 and 4.

**Total copper loss:** Length of the mean Turn can be calculated from the empirical formula  $l_{mt} = 2L + 2.3 \tau_p + 0.08 m$

Resistance of rotor winding is given by  $R_r = (0.021 \times l_{mt} \times T_r) / A_r$

Total copper loss =  $3 I_r^2 R_r$  Watts

**Flux density in rotor tooth:** It is required that the dimension of the slot is alright from the flux density consideration. Flux density has to be calculated at 1/3<sup>rd</sup> height from the root of the teeth. This flux density has to be limited to 1.8 Tesla. If not the width of the tooth has to be increased and width of the slot has to be reduced such that the above flux density limitation is satisfied. The flux density in rotor can be calculated by as shown below.

Diameter at 1/3rd height  $D_r' = D - 2/3 \times h_{tr} \times 2$

Slot pitch at 1/3rd height =  $\tau_r' = \pi \times D_r' / S_r$

Tooth width at this section =  $b_{tr}' = \tau_{sr}' - b_{sr}$

Area of one rotor tooth =  $a_{tr}' = b_{tr}' \times l_i$

Iron length of the rotor  $l_i = (L - w_d \times n_d) k_i$ ,  $k_i$  = iron space factor

Area of all the rotor tooth / pole  $A_{tr}' = b_{tr}' \times l_i \times S_r / P$

Mean flux density in rotor teeth  $B_{tr}' = \Phi / A_{tr}'$

Maximum flux density in the rotor teeth  $< 1.5$  times  $B_{tr}'$

**Depth of stator core below the slots:** Below rotor slots there is certain solid portion which is called depth of the core below slots. This depth is calculated based on the flux

density and flux in the rotor core. Flux density in the rotor core can be assumed to be between 1.2 to 1.4 Tesla. Then depth of the core can be found as follows.

Flux in the rotor core section  $\Phi_c = \frac{1}{2} \Phi$

Area of stator core  $A_{cr} = \Phi / 2B_{cr}$  Area

of stator core  $A_{cr} = L_i \times d_{cr}$  Hence,

depth of the core  $d_{cr} = A_{cr} / L_i$

Inner diameter of the rotor can be calculated as follows

Inner diameter of rotor =  $D - 2l_g - 2h_{tr} - 2d_{cr}$

**Ex.1.** During the stator design of a 3 phase, 30 kW, 400volts, 6 pole, 50Hz,squirrel cage induction motor following data has been obtained. Gross length of the stator = 0.17 m, Internal diameter of stator = 0.33 m, Number of stator slots = 45, Number of conductors per slot = 12. Based on the above design data design a suitable rotor.

**Soln:** (i) Diameter of the rotor

$$\begin{aligned} \text{Length of the air gap } l_g &= 0.2 + 2 \sqrt{DL} \text{ mm} \\ &= 0.2 + 2 \sqrt{0.33 \times 0.17} \text{ mm} \\ &= 0.67 \text{ mm} \end{aligned}$$

$$\begin{aligned} \text{Outer diameter of rotor } D_r &= D - 2l_g \\ &= 0.33 - 2 \times 0.67 \times 10^{-3} \\ &= 0.328 \text{ m} \end{aligned}$$

(ii) Number of rotor slots

(a)  $S_s > S_r$

(b) To avoid cogging and crawling:  $S_r \neq S_s$ ,  $S_s - S_r \neq \pm 3P$

$$S_r \neq 45, S_s - S_r \neq \pm 3P \rightarrow 45 - 18 \neq 27,$$

(c) To avoid synchronous hooks and cusps in torque speed characteristics  $S_s - S_r \neq \pm P, \pm 2P, \pm 5P$

$$S_s - S_r \neq (45 - 6), (45 - 12), (45 - 03) \neq 39, 33, 15$$

To avoid noisy operation  $S_s - S_r \neq \pm 1, \pm 2, (\pm P \pm 1), (\pm P \pm 2)$

$$S_s - S_r \neq (45 - 1), (45 - 2), (45 - 7), (45 - 8)$$

Considering all the combination above  $S_r = 42$

Rotor slot pitch =  $\pi D_r / S_r = \pi \times 32.8 / 42 = 2.45 \text{ cm}$  (quite satisfactory)

(iii) Rotor bar current

Assuming star – delta connection for stator winding

$$V_{ph} = 400 \text{ volts}$$

Assuming  $\eta = 88\%$  and  $p.f = 0.86$

$$\text{Motor input} = 30/0.88 = 30.1 \text{ kW}$$

$$\begin{aligned} \text{Full load stator current} &= \text{input} / 3 \text{ vph} \cos\Phi \\ &= 30.1 \times 10^3 / 3 \times 440 \times 0.86 \\ &= 33 \text{ amps} \end{aligned}$$

$$I'_r = 0.85 I_s = 0.85 \times 33 = 28 \text{ amps}$$

Assuming  $K_{ws} = 0.955$  & No. of rotor cond/slot = 1

$$\begin{aligned} I_b &= (K_{ws} \times S_s \times Z'_s) \times I'_r / (K_{wr} \times S_r \times Z'_r) \\ &= (0.955 \times 45 \times 12) \times 28 / (1 \times 42 \times 1) \\ &= 343.8 \text{ amps} \end{aligned}$$

(iv) Size of rotor bar and slot

Assuming the current density in rotor bars =  $6.0 \text{ amps/mm}^2$

$$A_r = I_r / \delta_r \text{ mm}^2$$

$$A_r = 343.8 / 6.0$$

$$= 57.3 \text{ mm}^2$$

Selecting rectangular standard conductor available

$$\text{Area of conductor} = 57.6 \text{ mm}^2$$

Hence standard conductor size =  $13 \text{ mm} \times 4.5 \text{ mm}$

Size of rotor slot to fit the above cond =  $13.5 \text{ mm} \times 5 \text{ mm}$

(v) Resistance of rotor bar

Length of rotor bar  $l_b = L + \text{allowance for skewing} + \text{allowance between end rings and rotor core}$

$$l_b = 0.17 + 0.05 = 0.22 \text{ m}$$

$$\begin{aligned}
 \text{Rotor bar resistance} &= 0.021 \times l_b / A_b \\
 &= 0.021 \times 0.22 / 57.6 \\
 &= 8.02 \times 10^{-5} \text{ ohm}
 \end{aligned}$$

$$\begin{aligned}
 \text{Copper loss in rotor bars} &= I_b^2 \times r_b \times \text{number of rotor bars} \\
 &= 343.8^2 \times 8.02 \times 10^{-5} \times 42 \\
 &= 398 \text{ watts}
 \end{aligned}$$

$$\begin{aligned}
 \text{(vii) End ring current } I_e &= 1/\pi \times Sr/P \times I_b \\
 &= 1/\pi \times 343.8 \times 7 \\
 &= 765.8 \text{ amps}
 \end{aligned}$$

(viii) Area of cross section of end ring

Assuming a current density of 6.5 Amp/mm<sup>2</sup>

$$\begin{aligned}
 \text{Area of each end ring } A_e &= I_e / \delta_e \text{ mm}^2, \\
 &= 765.7 / 6.5 \\
 &= 117.8 \text{ mm}^2
 \end{aligned}$$

(ix) Rotor dia  $D_r = 32.8 \text{ cm}$ ,

Assuming  $D_{me}$  4.8 cms less than that of the rotor  $D_{me} = 28 \text{ cms}$

Mean length of the current path in end ring  $l_{me} = \pi D_{me} = 0.88 \text{ m}$

$$\begin{aligned}
 \text{Resistance of each end ring } r_e &= 0.021 \times l_{me} / A_e \\
 &= 0.021 \times 0.88 / 117.8 \\
 &= 1.57 \times 10^{-4} \text{ ohms}
 \end{aligned}$$

$$\begin{aligned}
 \text{Total copper loss in end rings} &= 2 \times I_e^2 \times r_e \\
 &= 2 \times 765.72 \times 1.57 \times 10^{-4} \\
 &= 184 \text{ watts}
 \end{aligned}$$

Total copper loss = copper loss in bars + copper loss in end rings

$$= 398 + 184 = 582 \text{ watts}$$

Equivalent rotor resistance  $r' = \text{Total rotor copper loss} / (3 \times I_r'^2)$

$$= 582 / (3 \times 282)$$

$$= 0.247 \text{ ohms}$$

**Ex.2.** A 3 phase 200 kW, 3.3 kV, 50 Hz, 4 pole induction motor has the following dimensions. Internal diameter of the stator = 56.2 cm, outside diameter of the stator = 83cm, length of the stator = 30.5 cm, Number of stator slots = 60, width of stator slot = 1.47 cm, depth of stator slot = 4.3 cm, radial gap = 0.16 cm, number of rotor slots = 72, depth of rotor slot 3.55 cm, width of rotor slots = 0.95 cm. Assuming air gap flux density to be 0.5 Tesla, calculate the flux density in (i) Stator teeth (ii) Rotor teeth (iii) stator core.

**Soln:** (i) Flux density in Stator teeth

Internal diameter of stator = 56.2 cm, Depth of stator slot = 4.3 cm,

Diameter at  $1/3^{\text{rd}}$  height from narrow end of the stator teeth  $D' = D + 1/3 \times h_{ts} \times 2$

$$= 56.2 + 1/3 \times 4.3 \times 2$$

$$= 59.1 \text{ cm}$$

Slot pitch at  $1/3^{\text{rd}}$  height  $\tau'_s = \pi \times D' / S_s$

$$= \pi \times 59.1 / 60 = 3.1 \text{ cm}$$

Tooth width at this section  $b'_t = \tau'_s - b_s$

$$= 3.1 - 1.47$$

$$= 1.63 \text{ cm}$$

Area of one stator tooth  $a'_t = b'_t \times l_i$

$$l_i = k_i(L - n_d \times w_d) = 0.93(30.5 - 3 \times 1) = 25.6 \text{ cm}$$

Area of stator tooth  $A'_t = b'_t \times l_i$

$$= 25.6 \times 1.63$$

$$= 0.00418 \text{ m}^2$$

Number of stator teeth per pole =  $60 / 4 = 15$

Air gap area =  $\pi DL = \pi \times 0.562 \times 0.305 = 0.535 \text{ m}^2$

Total flux =  $B_{av} \times \pi DL = 0.5 \times 0.535 = 0.2675 \text{ wb}$

Hence flux per pole  $0.2675/4 = 0.06679 \text{ wb}$

Mean flux density in stator teeth  $B'_t = \Phi / (A'_t \times \text{no of teeth per pole})$

$$= 0.0669 / (0.00418 \times 15)$$

$$= 1.065 \text{ Tesla}$$

Max flux density in stator teeth =  $1.5 \times 1.065 = 1.6 \text{ Tesla}$ .

(ii) Flux density in rotor teeth

Diameter of the rotor =  $D - 2lg = 56.2 - 2 \times 0.16 = 55.88 \text{ cm}$

Depth of rotor slot =  $3.55 \text{ cm}$

Diameter at 1/3rd height  $D_r' = D - 2/3 \times h_{tr} \times 2 = 55.88 - 2/3 \times 3.55 \times 2 = 51.14 \text{ cm}$

Slot pitch at 1/3rd height =  $\tau'_r = \pi \times D_r' / S_r = \pi \times 51.14 / 72 = 2.23 \text{ cm}$

Width of the rotor slot =  $0.95 \text{ cm}$

Tooth width at this section =  $b'_{tr} = \tau'_{sr} - b_{sr} = 2.23 - 0.95 = 1.28 \text{ cm}$

Iron length  $l_i = 25.6 \text{ cm}$

Area of one rotor tooth =  $a'_{tr} = b'_{tr} \times l_i = 1.28 \times 25.6 = 32.8 \text{ cm}^2 = 0.00328 \text{ m}^2$

Number of rotor tooth per pole =  $72/4 = 18$

Area of all the rotor tooth / pole  $A'_{tr} = b'_t \times l_i \times S_r / P = 0.00328 \times 18 = 0.05904 \text{ m}^2$

Mean flux density in rotor teeth  $B'_{tr} = \Phi / A'_{tr} = 0.0669 / 0.05904 = 1.13 \text{ Tesla}$

Maximum flux density in the rotor teeth =  $1.5 \times 1.13 = 1.69 \text{ Tesla}$

(iii) Flux density in Stator core

Depth of the stator core  $d_c = \frac{1}{2} (D_0 - D - 2h_t) = \frac{1}{2} (83 - 56.2 - 2 \times 4.3) = 9.1 \text{ cm}$

Area of stator core  $A_c = l_i \times d_c = 25.6 \times 9.1 = 233 \text{ cm}^2 = 0.0233 \text{ m}^2$

Flux in stator core  $\Phi_c = \frac{1}{2} \Phi = 0.5 \times 0.0669 = 0.03345 \text{ wb}$

Flux density in stator core  $B_c = \Phi_c / A_c = 0.03345 / 0.0233 = 1.435 \text{ Tesla}$

**Ex.3.** A 3 phase 3000 volts 260 kW, 50 Hz, 10 pole squirrel cage induction motor gave the following results during preliminary design.

Internal diameter of the stator = 75 cm, Gross length of the stator = 35 cm, Number of stator slots = 120, Number of conductor per slot = 10. Based on the above data calculate the following for the squirrel cage rotor. (i) Total losses in rotor bars, (ii) Losses in end rings, (iii) Equivalent resistance of the rotor.

**Soln.** (i) Total losses in rotor bars

Number of stator slots = 120,

To confirm to the requirements the rotor slots can be selected in the following way

Number of rotor slots

a)  $S_s > S_r$

(b) To avoid cogging and crawling:  $S_r \neq S_s, S_s - S_r \neq \pm 3P$

$S_r \neq 120, S_s - S_r \neq \pm 3P \rightarrow 120 - 30 \neq 90,$

(c) To avoid synchronous hooks and cusps in torque speed characteristics  $S_s - S_r \neq \pm P, \pm 2P, \pm 5P$

$S_s - S_r \neq (120 - 10), (120 - 20), (120 - 50) \neq 110, 100, 70$

(d) To avoid noisy operation  $S_s - S_r \neq \pm 1, \pm 2, (\pm P \pm 1), (\pm P \pm 2)$

$S_s - S_r \neq (120 - 1), (120 - 2), (120 - 11), (120 - 12) \neq 119, 118, 109, 108$

Considering all the combination above  $S_r = 115$

Rotor slot pitch  $= \pi D / S_r = \pi \times 75 / 115 = 2.048 \text{ cm}$  (quite satisfactory)

Rotor bar current

Assuming  $\eta = 90 \%$  and p.f = 0.9

Motor input  $= 260 / 0.9 = 288.88 \text{ kW}$

Assuming star connection

Full load stator current  $= \text{input} / (\sqrt{3} V_L \cos\Phi)$   
 $= 288.88 \times 10^3 / (\sqrt{3} \times 3000 \times 0.9)$   
 $= 61.5 \text{ amps}$

$I'_r = 0.85 I_s = 0.85 \times 61.5 = 52.275 \text{ amps}$

Assuming  $K_{ws} = 0.955$  & No. of rotor cond/slot = 1

$$I_b = (K_{ws} \times S_s \times Z'_s) \times I'_r / (K_{wr} \times S_r \times Z'_r)$$

$$= (0.955 \times 120 \times 10) \times 52.275 / (1 \times 115 \times 1)$$

$$= 521 \text{ amps}$$

Area of rotor bar

Assuming the current density in rotor bars = 6.5 amps/mm<sup>2</sup>

$$A_b = I_b / \delta_b \text{ mm}^2$$

$$A_b = 521 / 6.5$$

$$= 80.2 \text{ mm}^2$$

Length of rotor bar  $l_b = L +$  allowance for skewing + allowance between end rings and rotor core

$$l_b = 0.35 + 0.05 = 0.4 \text{ m}$$

$$\text{Rotor bar resistance} = 0.021 \times l_b / A_b$$

$$= 0.021 \times 0.4 / 80.2$$

$$= 1.05 \times 10^{-4} \text{ ohm}$$

$$\text{Copper loss in rotor bars} = I_b^2 \times r_b \times \text{number of rotor bars}$$

$$= 521^2 \times 1.05 \times 10^{-4} \times 115$$

$$= 3278 \text{ watts}$$

(ii) Losses in end rings

$$\text{End ring current } I_e = 1/\pi \times S_r/P \times I_b$$

$$= 1/\pi \times (115/10) \times 521$$

$$= 1906 \text{ amps}$$

Area of cross section of end ring



Assuming a current density of 6.5 Amp/mm<sup>2</sup>

Area of each end ring  $A_e = I_e / \delta_e \text{ mm}^2$ ,

$$= 1906/6.5$$

$$= 293.2 \text{ mm}^2$$

Air gap length  $l_g = 0.2 + 2\sqrt{DL}$

$$= 0.2 + 2\sqrt{0.75 \times 0.35}$$

$$= 1.22 \text{ mm}$$

Rotor diameter  $D_r = D - 2 l_g$

$$= 75 - 0.122$$

$$= 74.878 \text{ cm}$$

Rotor dia  $D_r = 74.878 \text{ cm}$ ,

Assuming  $D_{me}$  6.878 cms less than that of the rotor  $D_{me} = 68 \text{ cms}$

Mean length of the current path in end ring  $l_{me} = \pi D_{me} = 2.136 \text{ m}$

Resistance of each end ring  $r_e = 0.021 \times l_{me} / A_e$

$$= 0.021 \times 2.136 / 293.2$$

$$= 1.529 \times 10^{-4} \text{ ohms}$$

Total copper loss in end rings  $= 2 \times I_e^2 \times r_e$

$$= 2 \times 1906^2 \times 1.529 \times 10^{-4}$$

$$= 1111.55 \text{ watts}$$

(iii) Equivalent rotor resistance

Total copper losses in the rotor = Copper loss in bars + copper loss in end rings

$$= 3278 + 1111.55$$

$$= 4389.55 \text{ watts}$$

$$\begin{aligned}
 \text{Equivalent Rotor resistance} &= \text{Rotor cu loss} / (3 I_r^2) \\
 &= 4389.55 / (3 \times 52.275^2) \\
 &= 0.535 \text{ ohm}
 \end{aligned}$$

**Ex.4.** Following design data have been obtained during the preliminary design of a 3 phase, 850 kW, 6.6 kV, 50 Hz, 12 pole slip ring induction motor. Gross length of stator core = 45 cm, internal diameter of the stator core = 122 cm, number of stator slots = 144, Number of conductors per slot = 10. For the above stator data design a wound rotor for the motor.

**Soln :** (i) Diameter of the rotor

$$\begin{aligned}
 \text{Length of the air gap } l_g &= 0.2 + 2 \sqrt{DL} \text{ mm} \\
 &= 0.2 + 2 \sqrt{1.22 \times 0.45} \text{ mm} \\
 &= 1.68 \text{ mm}
 \end{aligned}$$

$$\begin{aligned}
 \text{Outer diameter of rotor } D_r &= D - 2 l_g \\
 &= 1.22 - 2 \times 1.68 \times 10^{-3} \\
 &= 1.217 \text{ m}
 \end{aligned}$$

(ii) Number of rotor slots : Considering all the factors for selection of number of rotor slots, and selecting fractional slot winding, assuming number of rotor slots per pole per phase as  $3\frac{1}{2}$

$$\begin{aligned}
 \text{Total number of rotor slots} &= 3.5 \times 12 \times 3 = 126 \\
 \text{Rotor slot pitch} &= \pi D_r / S_r \\
 &= \pi \times 1.217 / 126 \\
 &= 0.0303 \text{ m (quite satisfactory)}
 \end{aligned}$$

(iii) Number of rotor turns: For this motor the voltage between slip rings must be less than 1000 volts. Assume the voltage between slip rings as 600 volts.

Assuming star connection for stator winding  $E_s = 6600/\sqrt{3} = 3810$  volts, Assuming  $K_{ws} = K_{wr} = 1$

Rotor winding will always be star connected

$$\text{Total number of stator conductors} = 144 \times 10$$

$$\text{Total number of stator turns per phase} = 144 \times 10 / (3 \times 2) = 240$$

$$\begin{aligned}
 \text{Rotor turns per phase } T_r &= (E_r/E_s) \times (K_{ws}/K_{wr}) T_s \\
 &= 600/\sqrt{3} \times 1 \times 240 / 3810 \\
 &= 22 \text{ turns}
 \end{aligned}$$

$$\text{Rotor conductors per phase} = 44,$$

$$\text{Number of slots per phase} = 126/3 = 42,$$

Therefore number of conductors per slot = 1.

Final rotor turns/phase = number of conductors per phase / 2 = 42 / 2 = 21

(iv) Rotor current

As the motor is of 850 kW, efficiency will be high, assuming an efficiency of 92% and  $\cos \phi = 0.91$

Input to the motor =  $850 / 0.92 = 924$  kW,

Full load stator current per phase  $I_s = 924 \times 10^3 / (3 \times 3180 \times 0.91)$   
 $= 88.8$  amps

Equivalent rotor current  $I_r' = 0.85 I_s = 0.85 \times 88.8 = 75.5$  amps

$$I_r = (K_{ws} \times S_s \times Z'_s) \times I_r' / (K_{wr} \times S_r \times Z'_r);$$

$$= (144 \times 10 \times 75.5) / 126 \times 1$$

$$= 863 \text{ amps}$$

(v) Size of rotor conductors

Assuming a current density of 5 Amp/mm<sup>2</sup> for the rotor conductors ,

Cross sectional area of the rotor conductor =  $863 / 5 = 172.6$  mm<sup>2</sup>

Size of the rotor conductors is too large and this conductor can not be used as it is and hence has to be stranded. Stranding the conductors into 4 rectangular strips of each area 43.1 mm<sup>2</sup>, in parallel,

Standard size of the rectangular strip selected = 11 mm x 4 mm,

Thus sectional area of the rectangular conductor  $43.1 \times 4 = 172.4$  mm<sup>2</sup>

Size of the rectangular conductor with insulation = 11.5 mm x 4.5 mm

(vi) Size of the rotor slot

Four strips of the rectangular conductor are arranged as 2 strips widthwise and 2 strips depthwise, with this arrangement the size of the slot can be estimated as follows

(a) width of the slot

Slot liner	2 x 1.5	3.0 mm
Clearance		1.0 mm
Total width of the slot		13.0 mm
(b) Depth of the slot		
Space occupied by the conductor	2 x 11.5	23.0 mm
Slot liner	3 x 1.5	4.5 mm
Wedge		3.5 mm
Lip		1.0 mm
Clearance		1.0 mm
Total depth of the slot		34.0 mm

Thus size of the rotor slot = 13 mm x 34 mm

(vi) Resistance and copper losses

$$\begin{aligned} \text{Length of the mean Turn } l_{mt} &= 2L + 2.3 \tau_p + 0.08 \text{ m} \\ l_{mt} &= 2 \times 0.45 + 2.3 (\pi \times 1.22 / 12) + 0.08 \text{ m} \\ &= 1.72 \text{ m} \end{aligned}$$

$$\begin{aligned} \text{Resistance of rotor winding is given by } R_r &= (0.021 \times l_{mt} \times T_r) / A_r \\ &= (0.021 \times 1.72 \times 21) / 172.4 \\ &= 0.0044 \text{ ohm} \end{aligned}$$

$$\begin{aligned} \text{Total copper loss} &= 3 I_r^2 R_r \text{ Watts} \\ &= 3 \times 863^2 \times 0.0044 \\ &= 9831 \text{ watts} \end{aligned}$$

### Performance Evaluation:

Based on the design data of the stator and rotor of an induction motor, performance of the machine has to be evaluated. The parameters for performance evaluation are iron losses, no load current, no load power factor, leakage reactance etc. Based on the values of these parameters design values of stator and rotor can be justified.

Iron losses: Iron losses are occurring in all the iron parts due to the varying magnetic field of the machine. Iron loss has two components, hysteresis and eddy current losses occurring in the iron parts depend upon the frequency of the applied voltage. The frequency of the induced voltage in rotor is equal to the slip frequency which is very low and hence the iron losses occurring in the rotor is negligibly small. Hence the iron losses occurring in the induction motor is mainly due to the losses in the stator alone. Iron losses occurring in the stator can be computed as given below.

(a) Losses in stator teeth:

The following steps explain the calculation of iron loss in the stator teeth

- (i) Calculate the area of cross section of stator tooth based on the width of the tooth at  $1/3^{\text{rd}}$  height and iron length of the core as  $A'_{ts} = b'_{ts} \times l_i \text{ m}^2$
- (ii) Calculate the volume all the teeth in stator  $V_{ts} = A'_{ts} \times h_{ts} \times S_s \text{ m}^3$
- (iii) Compute the weight of all the teeth based on volume and density of the material as  $W_{ts} = V_{ts} \times \text{density}$ . ( density of the material can be found in DDH) ( $7.8 \times 10^{-3} \text{ kg/m}^3$ )
- (iv) Corresponding to the operating flux density in the stator teeth of the machine iron loss per kg of the material can be found by referring to the graph on pp179 of DDH.
- (v) Total iron losses in teeth= Iron loss /kg x weight of all teeth  $W_{ts}$  ie result of (iii) x (iv)

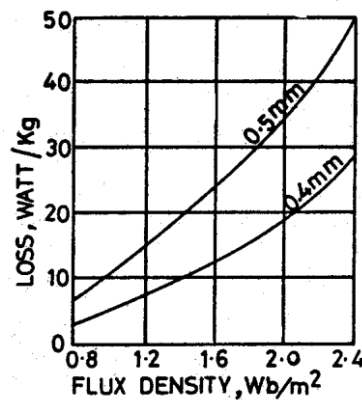

Fig. 18. Flux density vs iron loss

(c) Losses in stator core

Similar to the above calculation of iron loss in teeth, iron loss in stator core can be estimated.

- (i) Calculate the area of cross section of the core as  $A_{cs} = d_{cs} \times l_i \text{ m}^2$

- (ii) Calculate the mean diameter of the stator core below the slots as  $D_{mcs} = D + 2 h_{ts} + d_{cs}$  m
- (iii) Compute the volume of stator core as  $V_{cs} = A_{cs} \times \pi D_{mcs} m^3$
- (iv) Calculate the weight of the stator core as  $W_{cs} = V_{cs} \times \text{density}$
- (v) Corresponding to the operating flux density in the stator core of the machine iron loss per kg of the material can be found by referring to the graph on pp 179 of DDH.
- (vi) Total iron losses in core = Iron loss /kg x weight of core  $W_{cs}$  ie result of (iv) x (v)

Total iron losses in induction motor = Iron loss in stator core + iron losses in stator teeth.

In addition friction and windage loss can be taken into account by assuming it as 1- 2 % of the out put of the motor.

Hence total no load losses = Total iron losses + Friction and windage loss.

**No load current:** As seen from Fig 14, the no load current of an induction motor has two components magnetizing component,  $I_m$  and iron loss component,  $I_w$ . Phase relation between these currents is shown in Fig. 14.

Thus the no load current  $I_0 = \sqrt{(I_m)^2 + (I_w)^2}$  amps

**Magnetising current:** Magnetising current of an induction motor is responsible for producing the required amount of flux in the different parts of the machine. Hence this current can be calculated from all the magnetic circuit of the machine. The ampere turns for all the magnetic circuit such as stator core, stator teeth, air gap, rotor core and rotor teeth gives the total ampere turns required for the magnetic circuit. The details of the magnetic circuit calculations are studied in magnetic circuit calculations. Based on the total ampere turns of the magnetic circuit the magnetizing current can be calculated as

Magnetising current  $I_m = p AT_{30} / (1.17 k_w T_{ph})$

where  $p$  – no of pairs of poles,  $AT_{30}$  – Total ampere turns of the magnetic circuit at  $30^\circ$  from the centre of the pole,  $T_{ph}$  – Number of stator turns per phase.

**Iron loss component of current:** This component of current is responsible for supplying the iron losses in the magnetic circuit. Hence this component can be calculated from no load losses and applied voltage.

Iron loss component of current  $I_w = \text{Total no load losses} / (3 \times \text{phase voltage})$

**No load Power Factor:** No load power factor of an induction motor is very poor. As the load on the machine increases the power factor improves. No load power factor can be calculated knowing the components of no load current.

No load power factor  $\cos\Phi_0 = I_w / I_0$

**Ex.** While designing the stator of a 3 phase 10 kW, 400 volts, 50 Hz, 4 pole, wound rotor induction motor, following data are obtained.

Internal diameter of stator	= 0.19 m
Gross length	= 0.125 m
Number of stator slots	= 36
Number of conductors/slot	= 38
Dimension of stator slot	= 1.1 cm x 3.5 cm
Depth of the stator core	= 3 cm
Number of rotor slots	= 30
Dimension of the rotor slot	= 0.7 cm x 3.0 cm
Depth of rotor core	= 3.0 cm
Carter's coefficient for the air gap	= 1.33

Based on the above data, calculate the following performance data for this motor.

- (i) Flux per pole (ii) Iron losses (iii) Active component of no load current (iv) No load current (v) No load power factor

**Soln.** (i) Flux per pole

$$\text{Total number of stator conductors} = 36 \times 38 = 1368$$

$$\text{Stator turns per phase } T_{ph} = 1368 / 6 = 228$$

Assuming star delta connection for the motor  $V_{ph} = 400$  volts

Assuming  $E_{ph} = V_{ph} = 400$  volts, winding factor = 0.955

$$\begin{aligned} \text{Air gap flux per pole } \Phi &= E_{ph} / (4.44 f T_{ph} k_w) \\ &= 400 / (4.44 \times 50 \times 228 \times 0.955) \\ &= 0.00827 \text{ wb} \end{aligned}$$

(ii) Iron losses

Total Iron losses = Iron losses in stator teeth + Iron losses in stator core

Iron losses in stator teeth:

For the given stator length assuming one ventilating duct of width 1cm and iron space factor of 0.95,

$$\begin{aligned} L_i &= (L - n_d \times w_d) k_i \\ &= (0.125 - 1 \times 0.01) 0.95 \\ &= 0.109 \text{ m} \end{aligned}$$

$$\text{Diameter at } 1/3^{\text{rd}} \text{ height, } D' = D + 1/3 \times h_{ts} \times 2 = 0.19 + 1/3 \times 0.035 \times 2 = 0.213 \text{ m}$$

$$\text{Slot pitch at } 1/3^{\text{rd}} \text{ height} = \tau'_s = \pi \times D' / S_s = \pi \times 0.213 / 36 = 0.0186 \text{ m}$$

$$\text{Tooth width at this section} = b'_t = \tau'_s - b_s = 0.0186 - 0.011 = 0.0076 \text{ m}$$

$$\text{Area of the stator tooth per pole } A'_t = b'_t \times l_i \times \text{number of teeth per pole}$$

$$= b'_t \times l_i \times S_s / p = 0.0076 \times 0.109 \times 36 / 4$$

$$= 0.00746 \text{ m}^2$$

Mean flux density in stator teeth  $B'_t = \Phi / A'_t = 0.00827 / 0.00746 = 1.109 \text{ Tesla}$

Maximum flux density in stator tooth  $= 1.5 \times 1.109 = 1.66 \text{ Tesla}$

Volume of all the stator teeth  $= b'_t \times l_i \times \text{height of teeth} \times \text{number of teeth}$

$$= 0.0076 \times 0.109 \times 0.035 \times 36$$

$$= 0.001044 \text{ m}^3$$

Weight of all the teeth  $= \text{volume} \times \text{density}$

Assuming a density of  $7.8 \times 10^3 \text{ kg/m}^3$

Weight of all the teeth  $= 0.001044 \times 7.8 \times 10^3 = 8.14 \text{ kg}$

Total iron losses in the stator teeth  $= \text{Total weight} \times \text{loss/kg}$

Iron loss in the material at a flux density of 1.66 Tesla from graph PP-22 of DDH loss/kg  $= 23 \text{ w/kg}$

Total iron losses in the stator teeth  $= 23 \times 8.14 = 187.22 \text{ watts}$

Iron losses in stator core : Sectional area of the stator core  $= l_i \times d_c = 0.109 \times 0.03$   
 $= 0.00327 \text{ m}^2$

Mean diameter of the stator core below the slots  $= 0.19 + 2 \times 0.035 + 0.03 = 0.29 \text{ m}$

Volume of the stator core  $= \pi \times D \times A_{cs} = \pi \times 0.29 \times 0.00327 = 0.002979 \text{ m}^3$

Weight of the stator core  $= 0.002979 \times 7.8 \times 10^3 = 23.23 \text{ kg}$

Flux density in stator core  $= \Phi_c / A_{cs} = 0.00827 / (2 \times 0.00327) = 1.264 \text{ Tesla}$

At this flux density iron loss/kg  $= 17 \text{ watts/kg}$

Iron losses in the stator core  $= 17 \times 23.23 = 394.91 \text{ watts}$

Total iron losses in the stator  $= 187.22 + 394.91 = 582.13 \text{ watts}$

(iii) Active component of no load current

Assuming the friction and windage losses as 1% of output Friction and windage loss  $= 100 \text{ w}$

Total no load losses  $= 582.13 + 100 = 682.13 \text{ watts}$

Active component of no load current  $= \text{Iron loss component of current}$

$$I_w = \text{Total no load losses} / (3 \times \text{phase voltage}) = 682.13 / (3 \times 400) = 0.568 \text{ amps}$$

(iv) Magnetising current: In order to calculate the magnetizing current ampere turns required for the various parts of the magnetic circuits are to be calculated.

(a) Ampere turns for the stator core:

Pole pitch at the mean diameter of the stator core  $= \pi \times D / P = \pi \times 0.29 / 4 = 0.23 \text{ m}$

Length of the flux path in stator core  $= 1/3 \times 0.23 = 0.077 \text{ m}$

Ampere turns per meter at a flux density of 1.264 Tesla from graph (PP-22 of DDH) 400 AT

Hence total ampere turns required for the stator core  $= 400 \times 0.077 = 31$

(b) Ampere turns for the stator teeth:

Length of the flux path in stator teeth  $= 0.035 \text{ m}$



$$\begin{aligned}\text{Flux density in stator teeth at } 30^\circ \text{ from the pole centre} &= 1.36 B_t' \\ &= 1.36 \times 1.109 = 1.508 \text{ Tesla}\end{aligned}$$

Ampere turns per meter at a flux density of 1.508 Tesla (from graph PP-22 of DDH) is 1000 AT

$$\text{Hence total ampere turns for the stator teeth} = 1000 \times 0.035 = 35$$

(c) Ampere turns for the air gap:

$$\text{Length of the air gap} = 0.2 + 2\sqrt{DL} = 0.2 + 2\sqrt{0.19 \times 0.125} = 0.51 \text{ mm}$$

$$\text{Average flux density in the air gap} = \Phi / (\pi \times DL / P) = 0.4696 \text{ Tesla}$$

$$\text{Carter's coefficient for the air gap} = 1.33$$

$$\begin{aligned}\text{Air gap flux density at } 30^\circ \text{ from the centre of the pole } B_g &= 1.36 \times B_{av} \\ &= 1.36 \times 0.4696 \\ &= 0.6387 \text{ Tesla}\end{aligned}$$

$$\text{Hence Ampere turns for the air gap} = 796000 B_g k_g l_g$$

$$\begin{aligned}AT_g &= 796000 \times 0.687 \times 1.33 \times 0.51 \times 10^{-3} \\ &= 371 \text{ AT}\end{aligned}$$

(d) Ampere turns for the rotor Teeth :

$$\text{Diameter of the rotor} = D - 2l_g = 0.19 - 2 \times 0.00051 = 0.189 \text{ m}$$

$$\begin{aligned}\text{Diameter at } 1/3^{\text{rd}} \text{ height from the narrow end of the teeth } D_r' &= D - 2 \times 2/3 h_{rs} \\ &= 0.189 - 4/3 \times 0.03 \\ &= 0.149 \text{ m}\end{aligned}$$

$$\text{Slot pitch at } 1/3^{\text{rd}} \text{ height} = \tau_r' = \pi \times D_r' / S_r = \pi \times 0.149 / 30 = 0.0156 \text{ m}$$

$$\text{Tooth width at this section} = b_{tr}' = \tau_r' - b_r = 0.0156 - 0.007 = 0.0086 \text{ m}$$

$$\text{Area of the stator tooth per pole } A_{tr}' = b_{tr}' \times l_i \times \text{number of teeth per pole}$$

$$= 0.0086 \times 0.107 \times 30/4 = 0.0069 \text{ m}^2$$

$$\text{Flux density in rotor teeth at } 30^\circ \text{ from pole centre} = 1.36 \times 0.00827 / 0.0069 = 1.63 \text{ Tesla}$$

$$\text{Ampere turns/m at this flux density, from graph (PP-22 of DDH)} = 2800$$

$$\text{Length of flux path in rotor teeth} = 0.03 \text{ m}$$

$$\text{Ampere turns for the rotor teeth} = 2800 \times 0.03 = 84$$

(e) Ampere turns for the rotor core

$$\text{Depth of the rotor core } d_{cr} = 3 \text{ cm}$$

$$\text{Area of the rotor core } A_{cr} = 0.03 \times 0.107 = 0.00321 \text{ m}^2$$

$$\text{Flux in the rotor} = \frac{1}{2} \times 0.00827 = 0.004135 \text{ wb}$$

Flux density in the rotor core =  $0.004135/0.00321 = 1.29$  Tesla

Ampere turns/m at this flux density, from graph (PP-22 of DDH) = 380

Mean diameter of the rotor core =  $D_r - 2 \times h_r - d_{cr} = 0.189 - 2 \times 0.03 - 0.03 = 0.099$  m

Pole pitch at this section =  $\pi \times 0.099 / 4 = 0.078$  m

Length of the flux path in rotor core =  $1/3 \times 0.078 = 0.026$  m

Total ampere turns for the rotor core =  $380 \times 0.026 = 10$

Total Ampere turns for the magnetic circuit =  $31 + 35 + 371 + 84 + 10 = 531$  AT

Magnetising current  $I_m = p(AT_{30}) / (1.17 \times K_w \times T_{ph})$

$$= 2 \times 531 / (1.17 \times 0.955 \times 228)$$

$$= 4.2 \text{ amps}$$

(v) No load current

No load current per phase  $I_o = \sqrt{I_w^2 + I_m^2}$

$$= \sqrt{(0.56^2 + 4.2^2)}$$

$$= 4.24 \text{ amps}$$

(vi) No load power factor  $\cos \phi_0 = I_w/I_0 = 0.56/4.24 = 0.132$

### References

1. A Course in Electrical Machine Design – A. K. Sawhney
2. Design of Electrical Machines – V. N. Mittle
3. Performance and Design of A C Machines – M G Say
4. Design and Testing of Electrical Machines – M. V. Deshapande
5. Electrical Machine Design Data Book – Shanmugsundaram and Palani
6. [www.google.com](http://www.google.com) and related websites
7. [www.phasemotorparts.com](http://www.phasemotorparts.com)
8. [www.wikipedia.org](http://www.wikipedia.org)
9. Krishna Vasudevan et. al. Electrical Machines II, Indian Institute of Technology, Madras

## Design of Synchronous Machines

### Introduction

Synchronous machines are AC machines that have a field circuit supplied by an external DC source. Synchronous machines are having two major parts namely stationary part stator and a rotating field system called rotor.

In a synchronous generator, a DC current is applied to the rotor winding producing a rotor magnetic field. The rotor is then driven by external means producing a rotating magnetic field, which induces a 3-phase voltage within the stator winding.

Field windings are the windings producing the main magnetic field (rotor windings for synchronous machines); armature windings are the windings where the main voltage is induced (stator windings for synchronous machines).

### Types of synchronous machines

1. Hydrogenerators : The generators which are driven by hydraulic turbines are called hydrogenerators. These are run at lower speeds less than 1000 rpm.
2. Turbogenerators: These are the generators driven by steam turbines. These generators are run at very high speed of 1500rpm or above.
3. Engine driven Generators: These are driven by IC engines. These are run at aspeed less than 1500 rpm.

Hence the prime movers for the synchronous generators are Hydraulic turbines, Steam turbines or IC engines.

Hydraulic Turbines: Pelton wheel Turbines: Water head 400 m and above

Francis turbines: Water heads up to 380 m

Keplan Turbines: Water heads up to 50 m

Steam turbines: The synchronous generators run by steam turbines are called turbogenerators or turbo alternators. Steam turbines are to be run at very high speed to get higher efficiency and hence these types of generators are run at higher speeds.

Diesel Engines: IC engines are used as prime movers for very small rated generators.

### Construction of synchronous machines

1. Salient pole Machines: These type of machines have salient pole or projecting poles with concentrated field windings. This type of construction is for the machines which are driven by hydraulic turbines or Diesel engines.
2. Nonsalient pole or Cylindrical rotor or Round rotor Machines: These machines are having cylindrical smooth rotor construction with distributed field winding in slots. This type of rotor construction is employed for the machine driven by steam turbines.

1. Construction of Hydro-generators: These types of machines are constructed based on the water head available and hence these machines are low speed machines. These machines are constructed based on the mechanical consideration. For the given frequency the low speed demands large number of poles and consequently large

diameter. The machine should be so connected such that it permits the machine to be transported to the site. It is a normal to practice to design the rotor to withstand the centrifugal force and stress produced at twice the normal operating speed.

#### Stator core:

The stator is the outer stationary part of the machine, which consists of

- The outer cylindrical frame called yoke, which is made either of welded sheet steel, cast iron.
- The magnetic path, which comprises a set of slotted steel laminations called stator core pressed into the cylindrical space inside the outer frame. The magnetic path is laminated to reduce eddy currents, reducing losses and heating. CRGO laminations of 0.5 mm thickness are used to reduce the iron losses.

A set of insulated electrical windings are placed inside the slots of the laminated stator. The cross-sectional area of these windings must be large enough for the power rating of the machine. For a 3-phase generator, 3 sets of windings are required, one for each phase connected in star. Fig. 1 shows one stator lamination of a synchronous generator. In case of generators where the diameter is too large stator lamination can not be punched in on circular piece. In such cases the laminations are punched in segments. A number of segments are assembled together to form one circular laminations. All the laminations are insulated from each other by a thin layer of varnish.

Details of construction of stator are shown in Figs 2 -

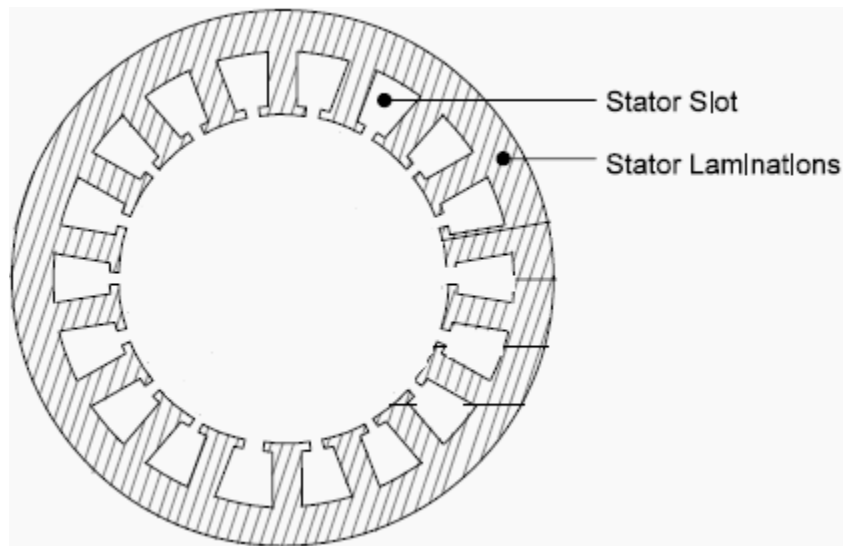

Fig. 1. Stator lamination

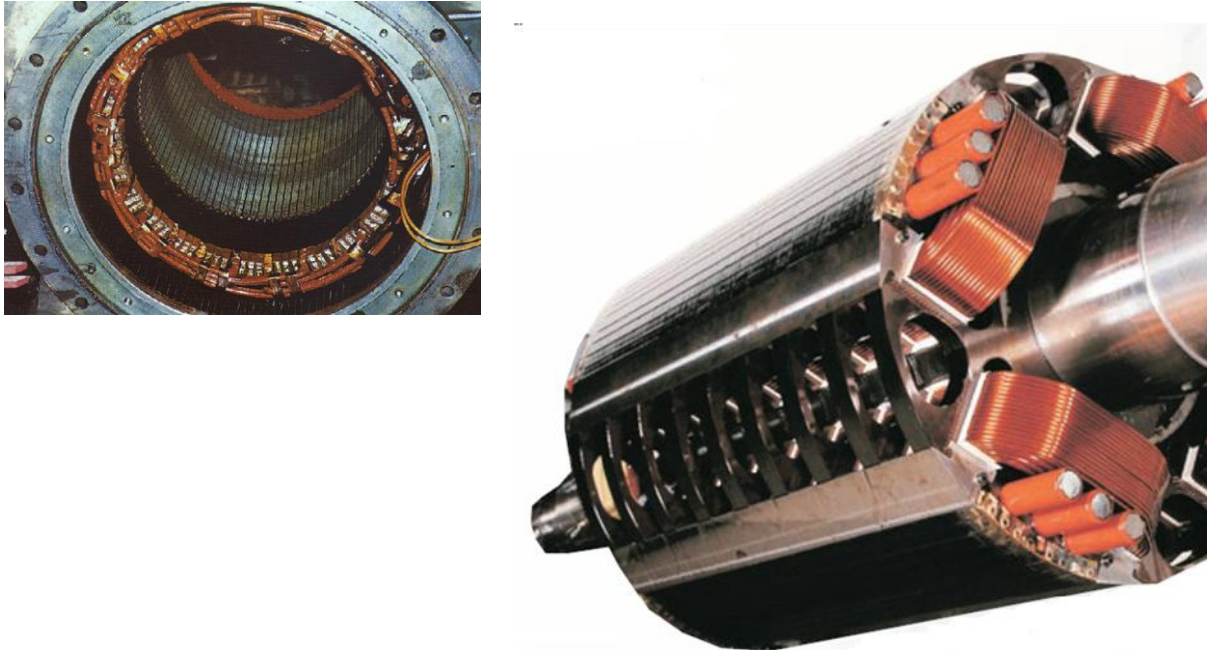

Fig 2. (a) Stator and (b) rotor of a salient pole alternator



Fig 3. (a) Stator of a salient pole alternator

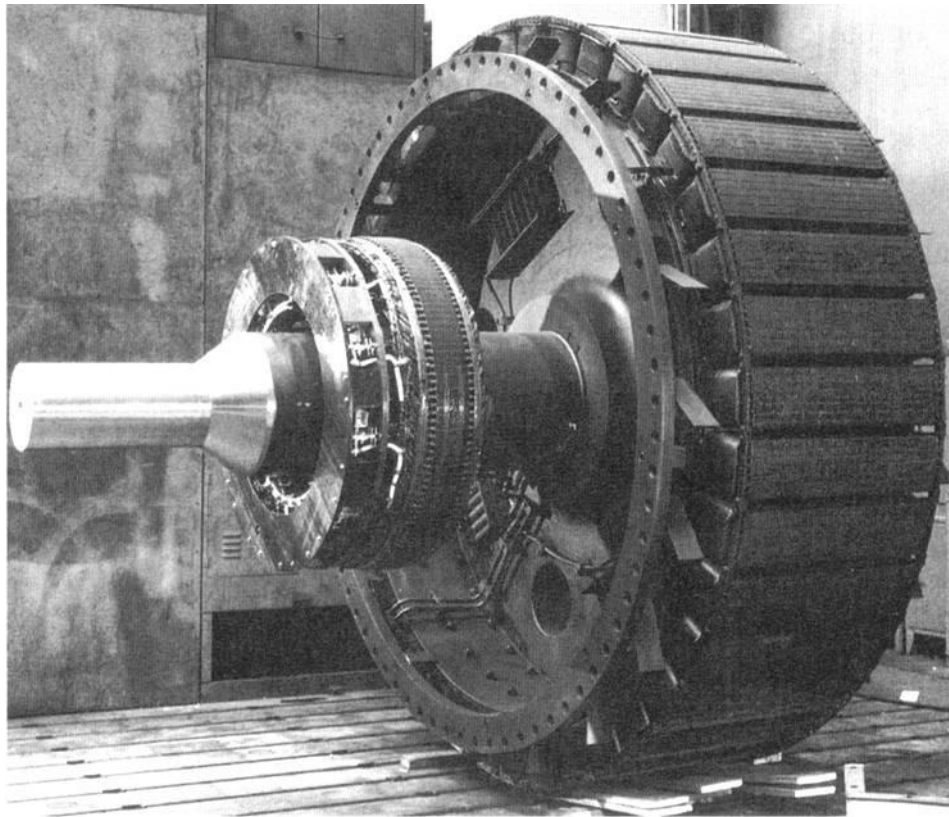
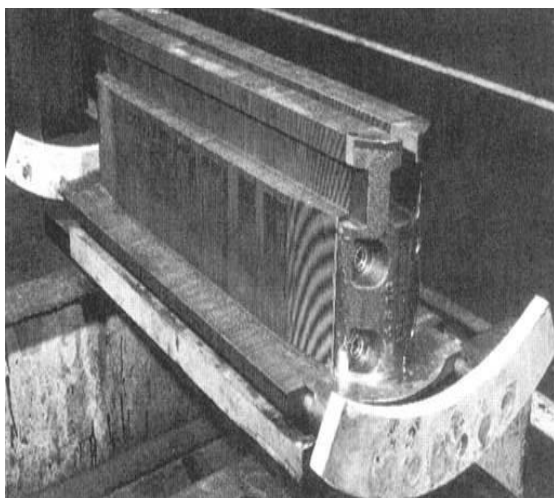
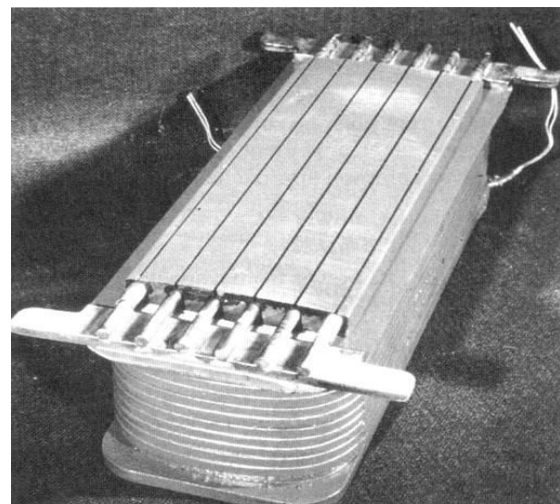

Fig 4. Rotor of a salient pole alternator



(a)



(b)

Fig 5. (a) Pole body (b) Pole with field coils of a salient pole alternator





Fig 6. Slip ring and Brushes

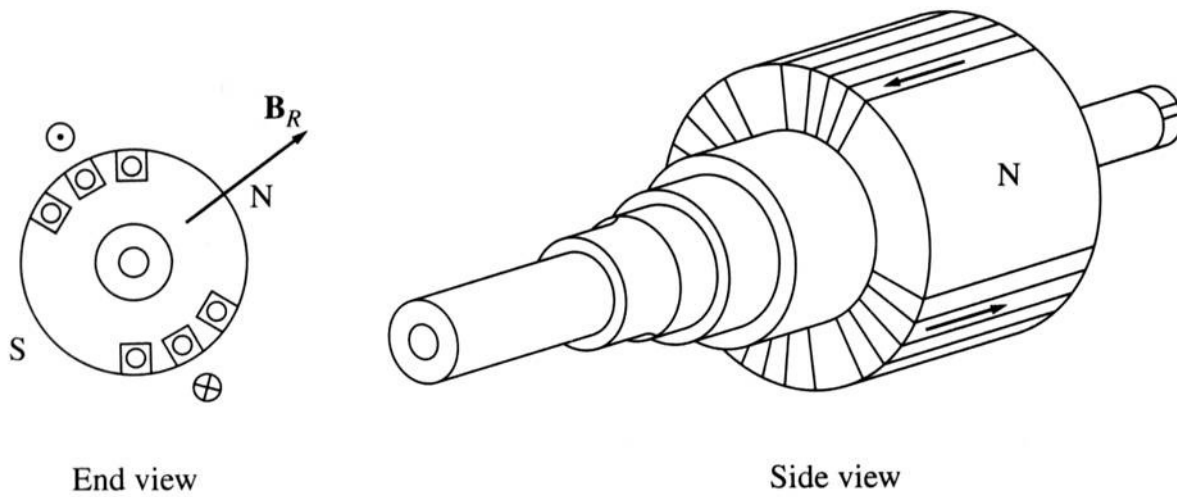

Fig 7. Rotor of a Non salient pole alternator

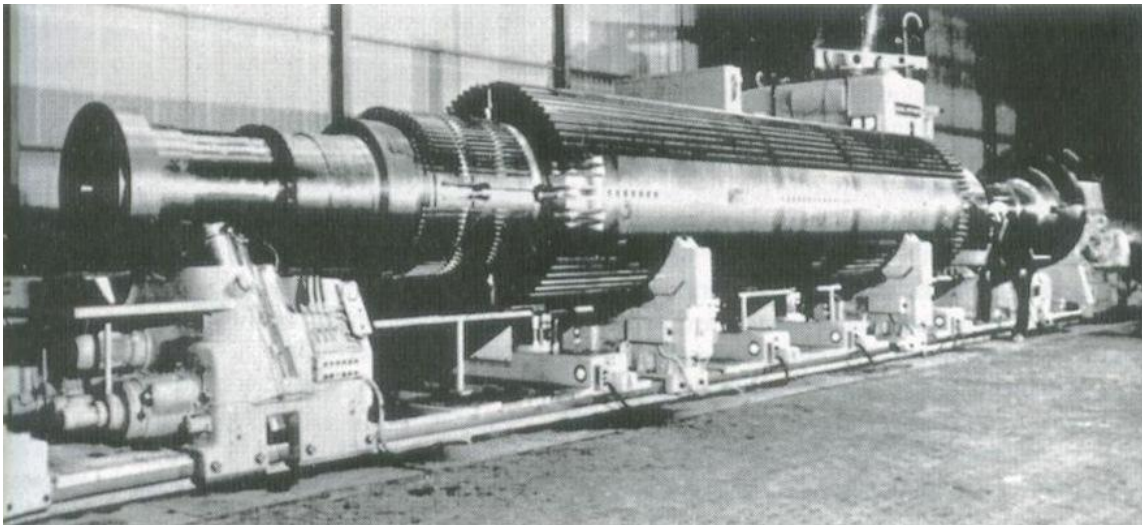
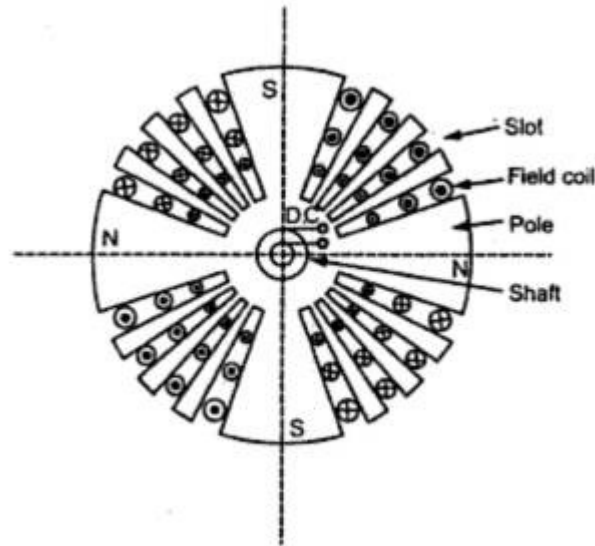

Fig 8. Rotor of a Non salient pole alternator

Rotor of water wheel generator consists of salient poles. Poles are built with thin silicon steel laminations of 0.5mm to 0.8 mm thickness to reduce eddy current laminations. The laminations are clamped by heavy end plates and secured by studs or rivets. For low speed rotors poles have the bolted on construction for the machines with little higher peripheral speed poles have dove tailed construction as shown in Figs. Generally rectangular or round pole constructions are used for such type of alternators. However the round poles have the advantages over rectangular poles.

Generators driven by water wheel turbines are of either horizontal or vertical shaft type. Generators with fairly higher speeds are built with horizontal shaft and the generators with higher power ratings and low speeds are built with vertical shaft design. Vertical shaft generators are of two types of designs (i) Umbrella type where in the bearing is mounted below the rotor. (ii) Suspended type where in the bearing is mounted above the rotor.

In case of turbo alternator the rotors are manufactured from solid steel forging. The rotor is slotted to accommodate the field winding. Normally two third of the rotor periphery is slotted to accommodate the winding and the remaining one third unslotted portion acts as the pole. Rectangular slots with tapering teeth are milled in the rotor. Generally rectangular aluminum or copper strips are employed for filed windings. The field windings and the overhangs of the field windings are secured in place by steel retaining rings to protect against high centrifugal forces. Hard composition insulation materials are used in the slots which can withstand high forces, stresses and temperatures. Perfect balancing of the rotor is done for such type of rotors.

Damper windings are provided in the pole faces of salient pole alternators. Damper windings are nothing but the copper or aluminum bars housed in the slots of the pole faces. The ends of the damper bars are short circuited at the ends by short circuiting rings similar to end rings as in the case of squirrel cage rotors. These damper windings are serving the function of providing mechanical balance; provide damping effect, reduce the effect of over voltages and damp out hunting in case of alternators. In case of synchronous motors they act as rotor bars and help in self starting of the motor.

### **Relative dimensions of Turbo and water wheel alternators:**

Turbo alternators are normally designed with two poles with a speed of 3000 rpm for a 50 Hz frequency. Hence peripheral speed is very high. As the diameter is proportional to the peripheral speed, the diameter of the high speed machines has to be kept low. For a given volume of the machine when the diameter is kept low the axial length of the machine increases. Hence a turbo alternator will have small diameter and large axial length.

However in case of water wheel generators the speed will be low and hence number of poles required will be large. This will indirectly increase the diameter of the machine. Hence for a given volume of the machine the length of the machine reduces. Hence the water wheel generators will have large diameter and small axial length in contrast to turbo alternators.

### **Introduction to Design**

Synchronous machines are designed to obtain the following informations.

- (i) Main dimensions of the stator frame.
- (ii) Complete details of the stator windings.
- (iii) Design details of the rotor and rotor winding.
- (iv) Performance details of the machine.

To proceed with the design and arrive at the design information the design engineer needs the following information.

- (i) Specifications of the synchronous machine.
- (ii) Information regarding the choice of design parameters.
- (iii) Knowledge on the availability of the materials.
- (iv) Limiting values of performance parameters.
- (v) Details of Design equations.

### **Specifications of the synchronous machine:**

Important specifications required to initiate the design procedure are as follows:

Rated output of the machine in kVA or MVA, Rated voltage of the machine in kV, Speed, frequency, type of the machine generator or motor, Type of rotor salient pole or non salient pole, connection of stator winding, limit of temperature, details of prime mover etc.

### Main Dimensions:

Internal diameter and gross length of the stator forms the main dimensions of the machine. In order to obtain the main dimensions it is required to develop the relation between the output and the main dimensions of the machine. This relation is known as the output equation.

### Output Equation:

Output of the 3 phase synchronous generator is given by

$$\text{Output of the machine } Q = 3V_{ph} I_{ph} \times 10^{-3} \text{ kVA}$$

$$\text{Assuming Induced emf } E_{ph} = V_{ph}$$

$$\text{Output of the machine } Q = 3E_{ph} I_{ph} \times 10^{-3} \text{ kVA}$$

$$\begin{aligned} \text{Induced emf } E_{ph} &= 4.44 f \Phi T_{ph} K_w \\ &= 2.22 f \Phi Z_{ph} K_w \end{aligned}$$

$$\text{Frequency of generated emf } f = P N_s / 120 = P n_s / 2,$$

$$\text{Air gap flux per pole } \Phi = B_{av} \pi D L / p, \text{ and Specific electric loading } q = 3 I_{ph} Z_{ph} / \pi D$$

$$\text{Output of the machine } Q = 3 \times (2.22 \times P n_s / 2 \times B_{av} \pi D L / p \times Z_{ph} \times K_w) I_{ph} \times 10^{-3} \text{ kVA}$$

$$\text{Output } Q = (1.11 \times B_{av} \pi D L \times n_s \times K_w) (3 \times I_{ph} Z_{ph}) \times 10^{-3} \text{ kVA}$$

Substituting the expressions for Specific electric loadings

$$\text{Output } Q = (1.11 \times B_{av} \pi D L \times n_s \times K_w) (\pi D q) \times 10^{-3} \text{ kVA}$$

$$Q = (1.11 \pi^2 D^2 L B_{av} q K_w n_s \times 10^{-3}) \text{ kVA}$$

$$Q = (11 B_{av} q K_w \times 10^{-3}) D^2 L n_s \text{ kVA}$$

$$\text{Therefore Output } Q = C_o D^2 L n_s \text{ kVA}$$

$$\text{or } D^2 L = Q / C_o n_s \text{ m}^3$$

$$\text{where } C_o = (11 B_{av} q K_w \times 10^{-3})$$

$V_{ph}$  = phase voltage ;  $I_{ph}$  = phase current  $E_{ph}$  = induced emf per phase

$Z_{ph}$  = no of conductors/phase in stator

$T_{ph}$  = no of turns/phase

$N_s$  = Synchronous speed in rpm

$n_s$  = synchronous speed in rps

$p$  = no of poles,       $q$  = Specific electric loading

$\Phi$  = air gap flux/pole;  $B_{av}$  = Average flux density

$k_w$  = winding factor

From the output equation of the machine it can be seen that the volume of the machine is directly proportional to the output of the machine and inversely proportional to the speed of the machine. The machines having higher speed will have reduced size and cost. Larger values of specific loadings smaller will be the size of the machine.

Choice of Specific loadings: From the output equation it is seen that choice of higher value of specific magnetic and electric loading leads to reduced cost and size of the machine.

Specific magnetic loading: Following are the factors which influences the performance of the machine.

- (i) Iron loss: A high value of flux density in the air gap leads to higher value of flux in the iron parts of the machine which results in increased iron losses and reduced efficiency.
- (ii) Voltage: When the machine is designed for higher voltage space occupied by the insulation becomes more thus making the teeth smaller and hence higher flux density in teeth and core.
- (iii) Transient short circuit current: A high value of gap density results in decrease in leakage reactance and hence increased value of armature current under short circuit conditions.
- (iv) Stability: The maximum power output of a machine under steady state condition is indirectly proportional to synchronous reactance. If higher value of flux density is used it leads to smaller number of turns per phase in armature winding. This results in reduced value of leakage reactance and hence increased value of power and hence increased steady state stability.
- (v) Parallel operation: The satisfactory parallel operation of synchronous generators depends on the synchronizing power. Higher the synchronizing power higher will be the ability of the machine to operate in synchronism. The synchronizing power is inversely proportional to the synchronous reactance and hence the machines designed with higher value air gap flux density will have better ability to operate in parallel with other machines.

Specific Electric Loading: Following are the some of the factors which influence the choice of specific electric loadings.

- (i) Copper loss: Higher the value of  $q$  larger will be the number of armature of conductors which results in higher copper loss. This will result in higher temperature rise and reduction in efficiency.

- (ii) Voltage: A higher value of  $q$  can be used for low voltage machines since the space required for the insulation will be smaller.
- (iii) Synchronous reactance: High value of  $q$  leads to higher value of leakage reactance and armature reaction and hence higher value of synchronous reactance. Such machines will have poor voltage regulation, lower value of current under short circuit condition and low value of steady state stability limit and small value of synchronizing power.
- (iv) Stray load losses: With increase of  $q$  stray load losses will increase.

Values of specific magnetic and specific electric loading can be selected from Design Data Hand Book for salient and nonsalient pole machines.

**Separation of D and L:** Inner diameter and gross length of the stator can be calculated from  $D^2L$  product obtained from the output equation. To separate suitable relations are assumed between D and L depending upon the type of the generator.

**Salient pole machines:** In case of salient pole machines either round or rectangular pole construction is employed. In these types of machines the diameter of the machine will be quite larger than the axial length.

**Round Poles:** The ratio of pole arc to pole pitch may be assumed varying between 0.6 to 0.7 and pole arc may be taken as approximately equal to axial length of the stator core. Hence

$$\text{Axial length of the core/ pole pitch} = L/\tau_p = 0.6 \text{ to } 0.7$$

**Rectangular poles:** The ratio of axial length to pole pitch may be assumed varying between 0.8 to 3 and a suitable value may be assumed based on the design specifications.

$$\text{Axial length of the core/ pole pitch} = L/\tau_p = 0.8 \text{ to } 3$$

Using the above relations D and L can be separated. However once these values are obtained diameter of the machine must satisfy the limiting value of peripheral speed so that the rotor can withstand centrifugal forces produced. Limiting values of peripheral speeds are as follows:

Bolted pole construction = 45 m/s

Dove tail pole construction = 75 m/s

Normal design = 30 m/s

**Turbo alternators:** These alternators will have larger speed of the order of 3000 rpm. Hence the diameter of the machine will be smaller than the axial length. As such the diameter of the rotor is limited from the consideration of permissible peripheral speed limit. Hence the internal diameter of the stator is normally calculated based on peripheral speed. The peripheral speed in case of turbo alternators is much higher than the salient pole machines. Peripheral speed for these alternators must be below 175 m/s.

**Short Circuit Ratio:**

It is defined as the ratio of field current required to produce rated voltage on open circuit to the field current reqd. to circulate rated current on short circuit.

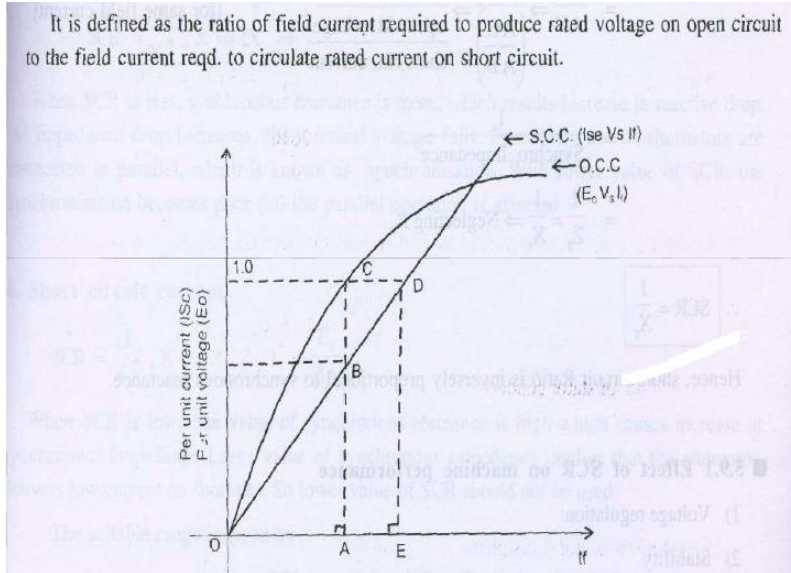

**Explanation**

The fig shows open Circuit and short Circuit characteristics of an alternator.

According to definition,

$$SCR = \frac{OA}{OE}$$

Triangles OAB and OED are similar

$$\text{Since } \frac{OA}{OB} = \frac{OE}{OD}$$

$$\frac{OA}{OB} = \frac{OE}{OD}$$

$$\frac{OA}{OB} = \frac{OE}{OD}$$

$$\text{Now, } \frac{OA}{OE} = \frac{AB}{ED} = \frac{OB}{OD}$$

$$\therefore SCR = \frac{AB}{ED}$$

$$= \frac{AB}{AC} \Rightarrow \frac{1}{\left(\frac{AC}{AB}\right)} \Rightarrow \frac{1}{\frac{\text{open ckt voltage}}{\text{short ckt. current}}}$$

$$= \frac{1}{\text{Synchro Impedance}}$$

$$= \frac{1}{Z_s} = \frac{1}{X_s} \Rightarrow \text{Neglecting } R_a$$

**Effect of SCR on Machine performance**

1. Voltage regulation
2. Stability
3. Parallel operation
4. Short circuit Current
5. Cost and size of the machine

**1. Voltage Regulation**

$$\downarrow \text{SCR} = \frac{1}{X_s \uparrow}, E_o \uparrow = \sqrt{(V \cos \phi + IR_a)^2 + (V \sin \phi \pm IX_s)^2}$$

$$\uparrow R = \frac{E_o \uparrow - V}{V}$$

**2. Stability**

$$\downarrow \text{SCR} = \frac{1}{X_s \uparrow}, P_{\text{Syn. Max}} \Rightarrow \frac{EV}{X_s \uparrow}, P_{\text{Syn. Max}} \downarrow \Rightarrow \text{Stability}$$

3. Parallel operation:  $\text{SCR} = 1/X_s$ , as  $\text{SCR} \uparrow$   $X_s \downarrow$   $IX_s \uparrow$   $V \downarrow$   $P_{\text{sync}} \downarrow$

**4. Short circuit current**

$$\downarrow \text{SCR} = \frac{1}{X_s \uparrow}, X_s \uparrow \Rightarrow Z_s \uparrow, Z_s \uparrow, I_{sc} \downarrow = \frac{E_s}{Z_s \downarrow}$$

**5. Size and cost of the machine**

as  $\text{SCR} \downarrow$   $X_s \uparrow$   $Z_s \uparrow$   $I_{sc} \downarrow$  and hence cost of control equipment reduces

For salient pole machines SCR value varies from 0.9 to 1.3

For turbo alternators SCR value varies from 0.7 to 1.1

**Length of the air gap:**

Length of the air gap is a very important parameter as it greatly affects the performance of the machine. Air gap in synchronous machine affects the value of SCR and hence it influences many other parameters. Hence, choice of air gap length is very critical in case of synchronous machines. Following are the advantages and disadvantages of larger air gap.

Advantages:

- (i) Stability: Higher value of stability limit
- (ii) Regulation: Smaller value of inherent regulation
- (iii) Synchronizing power: Higher value of synchronizing power
- (iv) Cooling: Better cooling
- (v) Noise: Reduction in noise
- (vi) Magnetic pull: Smaller value of unbalanced magnetic pull

Disadvantages:

- (i) Field mmf: Larger value of field mmf is required
- (ii) Size: Larger diameter and hence larger size
- (iii) Magnetic leakage: Increased magnetic leakage
- (iv) Weight of copper: Higher weight of copper in the field winding
- (v) Cost: Increase over all cost.



Hence length of the air gap must be selected considering the above factors.

Calculation of Length of air Gap: Length of the air gap is usually estimated based on the ampere turns required for the air gap.

Armature ampere turns per pole required  $AT_a = 1.35 T_{ph} k_w / p$

Where  $T_{ph}$  = Turns per phase,  $I_{ph}$  = Phase current,  $k_w$  = winding factor,  $p$  = pairs of poles

No load field ampere turns per pole  $AT_{fo} = SCR \times$  Armature ampere turns per pole

$$AT_{fo} = SCR \times AT_a$$

Suitable value of SCR must be assumed.

Ampere turns required for the air gap will be approximately equal to 70 to 75 % of the no load field ampere turns per pole.

$$AT_g = (0.7 \text{ to } 0.75) AT_{fo}$$

$$\text{Air gap ampere turns } AT_g = 796000 B_g k_g l_g$$

Air gap coefficient or air gap contraction factor may be assumed varying from 1.12 to 1.18.

As a guide line, the approximate value of air gap length can be expressed in terms of pole pitch

For salient pole alternators:  $l_g = (0.012 \text{ to } 0.016) \times$  pole pitch

For turbo alternators:  $l_g = (0.02 \text{ to } 0.026) \times$  pole pitch

Synchronous machines are generally designed with larger air gap length compared to that of Induction motors.

### Design of stator winding:

Stator winding is made up of former wound coils of high conductivity copper of diamond shape. These windings must be properly arranged such that the induced emf in all the phases of the coils must have the same magnitude and frequency. These emfs must have same wave shape and be displaced by  $120^\circ$  to each other. Single or double layer windings may be used depending on the requirement. The three phase windings of the synchronous machines are always connected in star with neutral earthed. Star connection of windings eliminates the 3<sup>rd</sup> harmonics from the line emf.

Double layer winding: Stator windings of alternators are generally double layer lap windings either integral slot or fractional slot windings. Full pitched or short chorded windings may be employed. Following are the advantages and disadvantages of double layer windings.

Advantages:

- (i) Better waveform: by using short pitched coil
- (ii) Saving in copper: Length of the overhang is reduced by using short pitched coils
- (iii) Lower cost of coils: saving in copper leads to reduction in cost
- (iv) Fractional slot windings: Only in double layer winding, leads to improvement in waveform

Disadvantages:

- (i) Difficulty in repair: difficult to repair lower layer coils
- (ii) Difficulty in inserting the last coil: Difficulty in inserting the last coil of the windings
- (iii) Higher Insulation: More insulation is required for double layer winding
- (iv) Wider slot opening: increased air gap reluctance and noise

**Number of Slots:**

The number of slots are to be properly selected because the number of slots affect the cost and performance of the machine. There are no rules for selecting the number of slots. But looking into the advantages and disadvantages of higher number of slots, suitable number of slots per pole per phase is selected. However the following points are to be considered for the selection of number of slots.

(a)

Advantages:

- (i) Reduced leakage reactance
- (ii) Better cooling
- (iii) Decreased tooth ripples

Disadvantages:

- (i) Higher cost
- (ii) Teeth becomes mechanically weak
- (iii) Higher flux density in teeth

(b) Slot loading must be less than 1500 ac/slot

(c) Slot pitch must be with in the following limitations

- (i) Low voltage machines  $\leq 3.5$  cm
- (ii) Medium voltage machines up to 6kV  $\leq 5.5$  cm
- (iv) High voltage machines up to 15 kV  $\leq 7.5$  cm

Considering all the above points number of slots per pole phase for salient pole machines may be taken as 3 to 4 and for turbo alternators it may be selected as much higher of the order of 7 to 9 slots per pole per phase In case of fractional slot windings number of slots per pole per phase may be selected as fraction 3.5.

**Turns per phase:**

Turns per phase can be calculated from emf equation of the alternator.

$$\text{Induced emf } E_{ph} = 4.44 f \Phi T_{ph} K_w$$

$$\text{Hence turns per phase } T_{ph} = E_{ph} / 4.44 f \Phi K_w$$

$E_{ph}$  = induced emf per phase

$Z_{ph}$  = no of conductors/phase in stator

$T_{ph}$  = no of turns/phase

$k_w$  = winding factor may assumed as 0.955

**Conductor cross section:** Area of cross section of stator conductors can be estimated from the stator current per phase and suitably assumed value of current density for the stator windings.

Sectional area of the stator conductor  $a_s = I_s / \delta_s$  where  $\delta_s$  is the current density in stator windings

$I_s$  is stator current per phase

A suitable value of current density has to be assumed considering the advantages and disadvantages.

Advantages of higher value of current density:

- (i) reduction in cross section
- (ii) reduction in weight
- (iii) reduction in cost

Disadvantages of higher value of current density

- (i) increase in resistance
- (ii) increase in cu loss
- (iii) increase in temperature rise
- (iv) reduction in efficiency

Hence higher value is assumed for low voltage machines and small machines. Usual value of current density for stator windings is 3 to 5 amps/mm<sup>2</sup>.

### Stator coils:

Two types of coils are employed in the stator windings of alternators. They are single turn bar coils and multi turn coils. Comparisons of the two types of coils are as follows

- (i) Multi turn coil winding allows greater flexibility in the choice of number of slots than single turn bar coils.
- (ii) Multi turn coils are former wound or machine wound whereas the single turn coils are hand made.
- (iii) Bending of top coils is involved in multi turn coils whereas such bends are not required in single turn coils.
- (iv) Replacing of multi turn coils is difficult compared to single turn coils.
- (v) Machine made multi turn coils are cheaper than hand made single turn coils.
- (vi) End connection of multi turn coils is easier than soldering of single turn coils.
- (vii) Full transposition of the strands of the single turn coils is required to eliminate the eddy current loss.
- (viii) Each turn of the multi turn winding is to be properly insulated thus increasing the amount of insulation and reducing the space available for the copper in the slot.

From the above discussion it can be concluded that multi turn coils are to be used to reduce the cost of the machine. In case of large generators where the stator current exceeds 1500 amps single turn coils are employed.

### Single turn bar windings:

The cross section of the conductors is quite large because of larger current. Hence in order to eliminate the eddy current loss in the conductors, stator conductors are to be stranded. Each slot of the stator conductor consists of two stranded conductors as shown in Fig XXX. The dimensions of individual strands are selected based on electrical considerations and the manufacturing requirements. Normally the width of the strands is assumed between 4 mm to 7 mm. The depth of the strands is limited based on the consideration of eddy current losses and hence it should not exceed 3mm. The various strand of the bar are transposed in such a way as to minimize the circulating current loss.

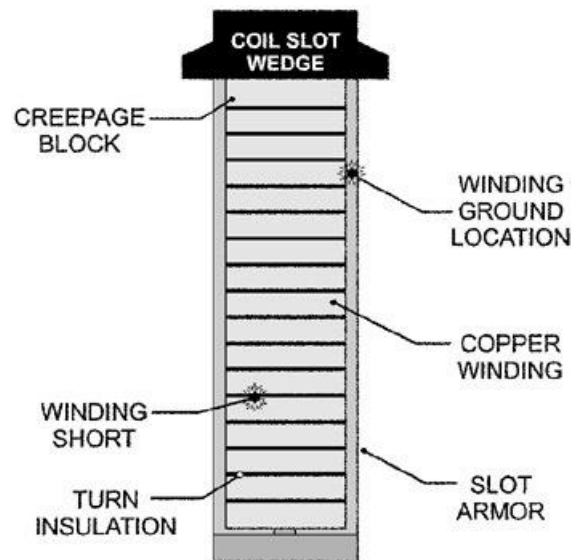

Fig XXX

### Multi turn coils:

Multi turn coils are former wound. These coils are made up of insulated high conductivity copper conductors. Mica paper tape insulations are provided for the portion of coils in the slot and varnished mica tape or cotton tape insulation is provide on the over hang portion. The thickness of insulation is decided based on the voltage rating of the machine. Multi turn coils are usually arranged in double layer windings in slots as shown in Fig XXX.

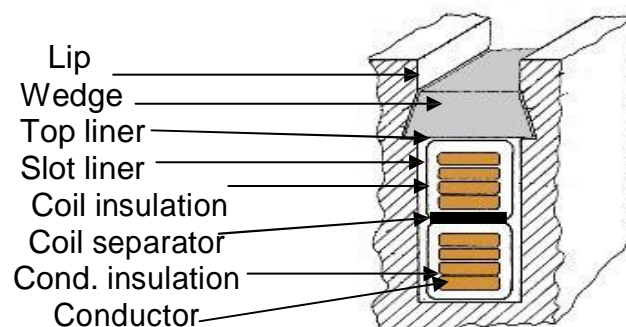

Fig. XXX

Width of the slot = slot pitch – tooth width

The flux density in the stator tooth should not exceed 1.8 to 2.0 Tesla. In salient pole alternators internal diameter is quite large and hence the flux density along the depth of the tooth does not vary appreciably. Hence width of the tooth may be estimated corresponding to the permissible flux density at the middle section of the tooth. The flux density should not exceed 1.8 Tesla. However in case of turbo alternators variation of flux density along the depth of the slot is appreciable and hence the width of the tooth may be estimated corresponding to the flux density at the top section of the tooth or the width of the tooth at the air gap. The flux density at this section should not exceed 1.8 Tesla.

For salient pole alternator:

Flux density at the middle section =

Flux / pole / ( width of the tooth at the middle section x iron length x number of teeth per pole arc)

Number of teeth per pole arc = pole arc/slot pitch

For turbo alternators:

Flux density at the top section =

Flux / pole / ( width of the tooth at the top section x iron length x number of teeth per pole pitch)

As the  $2/3^{\text{rd}}$  pole pitch is slotted the number of teeth per pole pitch =

$2/3 \times \text{pole pitch} / (\text{slot pitch at top section})$

Slot width = slot pitch at the top section – tooth width at the top section.

Once the width of the slot is estimated the insulation required width wise and the space available for conductor width wise can be estimated.

Slot insulation width wise:

- (i) Conductor insulation
- (ii) Mica slot liner
- (iii) Binding tape over the coil
- (iv) Tolerance or clearance

Space available for the conductor width wise = width of the slot – insulation width wise

We have already calculated the area of cross section of the conductor. Using above data on space available for the conductor width wise depth of the conductor can be estimated. Now the depth of the slot may be estimated as follows.

Depth of the slot:

- (i) Space occupied by the conductor = depth of each conductor x no. of conductor per slot
- (ii) Conductor insulation
- (iii) Mica slot liner
- (iv) Mica or bituminous layers to separate the insulated conductors
- (v) Coil separator between the layers
- (vi) Wedge
- (vii) Lip
- (viii) Tolerance or clearance

**Mean length of the Turn:**

The length of the mean turn depends on the following factors

- (i) Gross length of the stator core: Each turn consists of two times the gross length of stator core.
- (ii) Pole pitch: The over hang portion of the coils depend upon the coil span which in turn depends upon the pole pitch.
- (iii) Voltage of the machine: The insulated conductor coming out of the stator slot should have straight length beyond the stator core which depends upon the voltage rating of the machine.
- (iv) Slot dimension: Length per turn depends on the average size of the slot.

Hence mean length of the turn in double layer windings of synchronous machines is estimated as follows.

$$l_{mt} = 2l + 2.5 \tau_p + 5 kV + 15 \text{ cm}$$

**Numerical Problems:**

**Ex. 1** Design the stator frame of a 500 kVA, 6.6 kV, 50 Hz, 3 phase, 12 pole, star connected salient pole alternator, giving the following informations.

- (i) Internal diameter and gross length of the frame
- (ii) Number of stator conductors
- (iii) Number of stator slots and conductors per slot

Specific magnetic and electric loadings may be assumed as 0.56 Tesla and 26000 Ac/m respectively. Peripheral speed must be less than 40 m/s and slot must be less than 1200.

Soln:

- (i) Diameter and gross length of stator:

Assuming the winding to be full pitched  $K_w = 0.955$

$$\begin{aligned} \text{Output coefficient } C_o &= 11 \times B_{av} q K_w \times 10^{-3} \\ &= 11 \times 0.56 \times 26000 \times 0.955 \times 10^{-3} \\ &= 153 \end{aligned}$$

$$\begin{aligned} \text{Speed in rps } n_s &= 2f/p = 2 \times 50/12 \\ &= 8.33 \text{ rps} \end{aligned}$$

$$\text{Output } Q = C_o D^2 L n_s =$$

$$\begin{aligned} D^2 L &= Q / C_o n_s = 500 / (153 \times 8.33) \\ &= 0.392 \text{ m}^3 \end{aligned}$$

Using round poles for the salient pole alternator and assuming ratio of pole arc to pole pitch as 0.65 and pole arc equal to core length

$$\text{Pole arc/ pole pitch} = \text{core length/ pole pitch} = 0.65$$

$$L = \pi D/p = \pi D/12$$

$$L = 0.17D$$

Substituting this relation in  $D^2L$  product and solving for D and L  
 $D = 1.32 \text{ m}$  and  $L = 0.225 \text{ m}$ .

$$\begin{aligned} \text{Peripheral speed} &= \pi D n_s \text{ m/s} \\ &= \pi \times 1.32 \times 8.33 \\ &= 34.6 \text{ m/s (with in limitations)} \end{aligned}$$

(ii) Number of stator conductors

$$E_{ph} = 6600/\sqrt{3} = 3810 \text{ volts}$$

$$\begin{aligned} \text{Air gap flux per pole} &= B_{av} \times \pi DL/p \\ &= 0.56 \times \pi \times 1.32 \times 0.225/12 \\ &= 0.0436 \text{ wb} \end{aligned}$$

We have  $E_{ph} = 4.44f \Phi T_{ph} K_w$

$$\begin{aligned} \text{Hence } T_{ph} &= 3810 / (4.44 \times 50 \times 0.955 \times 0.0436) \\ &= 412 \end{aligned}$$

Total number of stator conductors/phase =  $412 \times 2 = 824$  conductors

Total number of conductors =  $412 \times 6 = 2472$  (iii)

Number of stator slots and conductors per slot

Considering the guide lines for selection of number of slots

Selecting the number of slots/pole/phase = 3

Total number of slots =  $3 \times 12 \times 3 = 108$

$$\begin{aligned} \text{Slot pitch} &= \pi D/S \\ &= \pi \times 132 / 108 \\ &= 2.84 \text{ cm (quite satisfactory)} \end{aligned}$$

Number of conductors per slot =  $2472/108$   
 $\approx 24$

Hence total number of conductors =  $24 \times 108 = 2592$

Turns per phase =  $2592/6 = 432$

Slot loading:

$$\begin{aligned} \text{Full load current} &= 500 \times 10^3 / (\sqrt{3} \times 6600) \\ &= 43.7 \text{ amps} \end{aligned}$$

Slot loading = current per conductor x number of conductors/ slot



$$= 43.7 \times 24$$

$$= 1048.8 \text{ (satisfactory)}$$

**Ex. 2.** A 3 phase 1800 kVA, 3.3 kV, 50 Hz, 250 rpm, salient pole alternator has the following design data.

Stator bore diameter = 230 cm

Gross length of stator bore = 38 cm

Number of stator slots = 216

Number of conductors per slot = 4

Sectional area of stator conductor = 86 mm<sup>2</sup>

Using the above data, calculate

- (i) Flux per pole
- (ii) Flux density in the air gap
- (iii) Current density
- (iv) Size of stator slot

**Soln:**

- (i) Flux per pole

$$E_{ph} = 3300/\sqrt{3} = 1905 \text{ volts}$$

$$\text{Number of slots per phase } 216/3 = 72$$

$$\text{Number of conductors per slot} = 4$$

$$\text{Total number of conductors per phase} = 72 \times 4 = 288$$

$$\text{Number of turns per phase } T_{ph} = 288/2 = 144$$

We have from emf equation  $E_{ph} = 4.44f \Phi T_{ph} K_w$

Assuming  $K_w = 0.955$

$$\begin{aligned} \text{Flux per pole } \Phi &= E_{ph} / (4.44f T_{ph} K_w) \\ &= 1905 / (4.44 \times 50 \times 144 \times 0.955) \\ &= 0.0624 \text{ wb} \end{aligned}$$

- (ii) Flux density in the air gap

$$\text{Air gap flux per pole} = B_{av} \times \pi DL/p$$

$$D = 230 \text{ cm,}$$

$$L = 38 \text{ cm,}$$

$$N_s = 250 \text{ rpm}$$

$$P = 24$$

$$\begin{aligned} B_{av} &= \Phi / \pi DL/p \\ &= 0.0624 \times 24 / (\pi \times 2.3 \times 0.38) \\ &= 0.55 \text{ Tesla} \end{aligned}$$

- (iii) Current density

$$\text{Sectional area of the conductor} = 86 \text{ mm}^2$$

$$\begin{aligned} \text{Full load current of the machine} &= 1800 \times 10^3 / (\sqrt{3} \times 3300) \\ &= 314.9 \text{ amps} \end{aligned}$$

$$\begin{aligned} \text{Hence Current density} &= 314.9/86 \\ &= 3.7 \text{ amp/mm}^2 \end{aligned}$$

(iv) Size of the stator slot

Before fixing up the width of the slot flux density in the middle section of the tooth has to be assumed as 1.7 Tesla. Based on this flux density width of the slot at the middle section can be found.

$$\text{Flux per pole} = 0.0624 \text{ wb}$$

$$\text{Gross length of the core} = 38 \text{ cm}$$

Assume

$$\text{Number of ventilating duct} = 4$$

$$\text{Width of the ventilating duct} = 1 \text{ cm}$$

$$\text{Iron space factor} = 0.92$$

$$\begin{aligned} \text{Net iron length of the core } l_i &= (L - nd \times wd)k_i \\ &= (38 - 4 \times 1) 0.92 \\ &= 31.28 \text{ cm} \end{aligned}$$

$$\begin{aligned} \text{Pole pitch} &= \pi D/p \\ &= \pi \times 230/24 \\ &= 30.12 \text{ cm} \end{aligned}$$

$$\text{Pole arc/ pole pitch} = 0.65 \text{ ( Assumed)}$$

$$\begin{aligned} \text{Pole arc} &= 0.65 \times \text{pole pitch} \\ &= 0.65 \times 30.12 \\ &= 19.6 \text{ cm} \end{aligned}$$

$$\text{Number of stator teeth} = 216$$

$$\begin{aligned} \text{Slot pitch} &= \pi D/s \\ &= \pi \times 230/216 \\ &= 3.35 \text{ cm} \end{aligned}$$

$$\begin{aligned} \text{Number of teeth per pole arc} &= \text{pole arc/ slot pitch} \\ &= 19.6/3.35 \\ &= 6 \end{aligned}$$

$$\begin{aligned} \text{Flux density in stator teeth} &= \text{flux per pole} / ( b_t \times l_i \times \text{number of teeth per pole arc}) \\ b_t &= 0.0624 / ( 1.7 \times 0.3128 \times 6) \\ &= 1.95 \text{ cm} \end{aligned}$$

$$\begin{aligned} \text{Thus the width of the slot should not exceed} &= 3.35 - 1.95 \\ &= 1.4 \text{ cm} \end{aligned}$$

Slot insulation width wise:

(i) Conductor insulation	2 x 0.5	= 1.0 mm
(ii) Micanite slot liner	2 x 1.5	= 3.0 mm
(iii) Binding tape	2 x 0.4	= 0.8 mm
(iv) tolerance		= 1.2 mm

---

$$\text{Total} = 6.0 \text{ mm}$$

$$\begin{aligned} \text{Maximum space available for the conductor width wise} &= \text{width of the slot} - \text{insulation width wise} \\ &= 1.4 - 0.6 \\ &= 0.8 \text{ cm} \end{aligned}$$

$$\text{Area of cross section of the conductor} = 86 \text{ mm}^2$$

$$\text{Hence thickness of the conductor} = 86/8 = 10.75 \text{ mm}$$

$$\text{Hence the dimension of the standard conductor selected} = 7.8 \text{ mm} \times 11.0 \text{ mm}$$

$$\text{Hence the width of the conductor} = 7.8 + 6.0 = 13.8 \text{ mm} = 1.38 \text{ cm}$$

Arrangement of the conductor:

All the four conductors are arranged depth wise

Depth of the slot:

(i) Space occupied by the conductor	4 x 11	= 44.0 mm
(ii) Conductor insulation	4 x 2 x 0.5	= 4.0 mm
(iii) Micanite slot liner	2 x 1.5	= 3.0 mm
(iv) Bituminous insulation between the insulated conductors	(4-1) x 0.2	= 0.6 mm
(v) Binding tape on the conductors	2 x 0.4	= 0.8 mm
(vi) Lip		= 1.5 mm
(vii) Wedge		= 3.5 mm
(viii) Tolerance		= 1.6 mm
	Total	59 mm

$$\text{Size of the slot} = 1.38 \text{ cm} \times 5.9 \text{ cm}$$

**Ex.3.** A water wheel generator with power output of 4750 kVA, 13.8 kV, 50 Hz, 1000 rpm, working at a pf of 0.8 has a stator bore and gross core length of 112 cm and 98 cm respectively. Determine the loading constants for this machine.

Using the design constants obtained from the above machine determine the main dimensions of the water wheel generator with 6250 kVA, 13.8 kV, 50 Hz, 750 rpm operating at a power factor of 0.85. Also determine (i) Details of stator winding (ii) Size of the stator slot, (iii) Copper losses in the stator winding.

For 4750 kVA Generator:

$$D = 112 \text{ cm}$$

$$L = 98 \text{ cm}$$

$$N_s = 1000 \text{ rpm}$$

$$N_s = 1000/60 = 16.67 \text{ rps}$$

$$\text{kVA out put } Q = C_0 D^2 L n_s$$

$$C_0 = Q / D^2 L n_s$$

$$= 4750 / [(1.12)^2 \times 0.98 \times 16.67]$$

$$= 232$$

$$\text{Output coefficient } C_o = 11 \times B_{av} \times q \times K_w \times 10^{-3}$$

$$\begin{aligned} \text{Hence } B_{av} \times q &= C_o / (11 \times K_w \times 10^{-3}) \\ &= 232 / (11 \times 0.955 \times 10^{-3}) \\ &= 22200 \end{aligned}$$

Assuming the flux density of 0.6 Tesla

$$\text{Hence } q = 22200/0.6 = 37000 \text{ Ac/m}$$

### Main Dimensions of the second machine:

$$\text{kVA out put } Q = C_o D^2 L n_s$$

$$C_o = 232$$

$$Q = 6250 \text{ kVA}$$

$$N_s = 750 \text{ rpm}$$

$$N_s = 750/60 = 12.5 \text{ rps}$$

$$\begin{aligned} D^2 L &= Q / C_o n_s \\ &= 6250 / 232 \times 12.5 \\ &= 2.16 \text{ m}^3 \end{aligned}$$

$$\begin{aligned} \text{For the first machine pole pitch } \tau_p &= \pi D/p \\ &= \pi \times 112/6 \\ &= 58.6 \text{ cm} \end{aligned}$$

$$\begin{aligned} \text{Core length / pole pitch} &= \text{gross length/ pole pitch} \\ &= 98/58.6 \\ &= 1.67 \end{aligned}$$

$$\text{No. of poles for the second machine } p = 120f/N_s = 120 \times 50 / 750 = 8$$

Assuming the same ratio of gross length to pole pitch for the second machine as that of first machine

$$\begin{aligned} L / \pi D/p &= 1.67 \\ L &= 1.67 \times \pi D/8 \\ &= 0.655 D \end{aligned}$$

$$\text{We have } D^2 L = 2.16 \text{ m}^3$$

Substituting the value of L in  $D^2 L$  and solving for D & L

$$D = 149 \text{ cm and } L = 97.5 \text{ cm}$$

$$\text{Peripheral speed for machine 1: } \pi D N_s / 60 = \pi \times 1.12 \times 1000/60 = 58.5 \text{ m/s}$$

Peripheral speed for machine 2:  $\pi D N_s / 60 = \pi \times 1.49 \times 750 / 60 = 58.5 \text{ m/s}$

As the peripheral speed is same for both the machines the diameter and length of the machine are satisfactory.

Stator winding details:

Assuming star connection emf per phase  $E_{ph} = 13.8 / \sqrt{3} = 7960 \text{ volts}$

We have from emf equation  $E_{ph} = 4.44 f \Phi T_{ph} K_w$

Assuming  $K_w = 0.955$ ,  $f = 50 \text{ Hz}$

Air gap flux per pole  $= B_{av} \times \pi DL / p$

Assuming the air gap flux density of machine 2 same as that of machine 1  $B_{av} = 0.6 \text{ Tesla}$

Hence  $= B_{av} \times \pi DL / p = 0.6 \times \pi \times 1.49 \times 0.975 / 8 = 0.342 \text{ wb}$

Hence  $T_{ph} = E_{ph} / 4.44 f \Phi K_w$

$= 7960 / (4.44 \times 50 \times 0.342 \times 0.955)$

$= 110$

Total number of Conductors  $= 110 \times 6 = 660$

Full load current per phase  $I_{ph} = 6250 \times 10^3 / \sqrt{3} \times 13.8 \times 10^3$   
 $= 262 \text{ amps}$

Assuming number of slots per pole per phase  $= 4 \frac{1}{2}$

Total number of slots  $= 4.5 \times 8 \times 3 = 108$

Slot pitch  $= \pi D / s = \pi \times 149 / 108 = 4.35 \text{ cm}$  ( quite satisfactory)

Number of conductors per slot  $= 660 / 108 \approx 6$

Total number of conductors revised  $= 108 \times 6 = 648$

Number of turns/phase  $= 108$

Total slot loading  $= I_{ph} \times \text{Cond/slot}$

$= 262 \times 6 = 1572 \text{ amp cond}$  (quite satisfactory)

Dimension of the stator slot:

Full load current per phase  $I_{ph} = 6250 \times 10^3 / \sqrt{3} \times 13.8 \times 10^3$   
 $= 262 \text{ amps}$

Assuming a current density of  $4.2 \text{ amps/mm}^2$

Area of cross section of the conductor  $= 262 / 4.2 = 62.4 \text{ mm}^2$

Based on the allowable flux density, width of the stator tooth can be calculated and then the width of the slot can be estimated.

Flux density in stator tooth  $B_t = \frac{\Phi}{\text{(Number of teeth/pole arc} \times \text{width of the teeth} \times \text{Iron length)}}$

In a large salient pole alternator the flux density in the tooth along the depth of the tooth does not vary appreciably. Thus the flux density at the top of the tooth may be assumed as 1.7 Tesla and the width of the tooth is calculated at the top section.

Hence number of teeth per pole arc = pole arc/ slot pitch

Assuming pole arc/ pole pitch = 0.65

Pole arc = 0.65 x 58.6 = 38.1 cm

Thus the number of teeth per pole arc = 38.1/4.35 = 9

Net Iron length =  $(L - n_d w_d) k_i$

Assuming 10 ventilating ducts of each 1 cm width and an iron space factor of 0.92

$L_i = (97.5 - 10 \times 1)0.92 = 80.5 \text{ cm} = 0.805 \text{ m}$

$B_t = \frac{\phi}{(\text{Number of teeth/pole arc} \times L_i)}$   
 $= 0.342 / (9 \times b_t \times 0.805)$

Assuming the flux density  $B_t$  as 1.7 Tesla

Hence width of the teeth = 2.78 cm

We have the slot pitch = 4.35 cm

Thus the slot pitch = 4.35 – 2.78 = 1.55 cm

Slot insulation width wise:

Slot insulation width wise:

(i) Conductor insulation	2 x 0.5	= 1.0 mm
(ii) Micanite slot liner	2 x 1.5	= 3.0 mm
(iii) Binding tape	2 x 0.25	= 0.5 mm
(iv) tolerance		= 1.0 mm
	<b>Total</b>	<b>= 5.5 mm</b>

Insulation depth wise:

(i) Conductor insulation	6 x 2 x 0.5	= 6.0 mm
(ii) Micanite slot liner	2 x 1.5	= 3.0 mm
(iii) Bituminous insulation between the insulated conductors	(6-1) x 0.3	= 1.5 mm
(iv) coil separator between layers		= 0.4 mm
(iv) Binding tape on the conductors	6 x 2 x 0.25	= 3.0 mm
(v) Lip		= 1.0 mm
(vi) Wedge		= 3.0 mm
(vii) Tolerance		= 1.6 mm

Total	19.5 mm
-------	---------

Maximum space available for the conductor width wise = width of the slot – insulation width wise  
 $= 1.55 - 0.55$   
 $= 1.0 \text{ cm}$

The area of cross section of the conductor =  $62.4 \text{ mm}^2$

Approximate depth of the conductor =  $62.4 / 10 = 6.2 \text{ mm}$

Selecting the standard conductor of size  $9 \text{ mm} \times 7 \text{ mm}$

Thus the area of the conductor =  $63 \text{ mm}^2$

Six conductors are arranged as 3 conductors depth wise in two layers.

Hence width of the slot =  $9 \text{ mm} + 5.5 \text{ mm} = 14.5 \text{ mm} = 1.45 \text{ cm}$

Depth of the slot =  $6 \times 7 + 19.5 \text{ mm} = 61.5 \text{ mm} = 6.15 \text{ cm}$

Copper loss in stator winding

Approximate length of the mean turn =  $(2L + 2.5 \tau_p + 5 \times kV + 15)$   
 $= (2 \times 97.5 + 2.5 \times 58.6 + 5 \times 13.8 + 15)$   
 $= 426 \text{ cm}$   
 $= 4.26 \text{ m}$

Resistance of the stator winding =  $\zeta \times l_{mt} \times T_{ph} / a$   
 $= 0.021 \times 4.26 \times 108 / 63$   
 $= 0.153 \text{ ohm}$

Total Copper losses =  $3 I^2 R$   
 $= 3 \times (262)^2 \times 0.153$   
 $= 31500 \text{ watts}$

**Ex. 4.** Two preliminary designs are made for a 3 phase alternator, the two designs differing only in number and size of the slots and the dimensions of the stator conductors. The first design uses two slots per pole per phase with 9 conductors per slot, each slot being 75 mm deep and 19 mm wide, the mean width of the stator tooth is 25 mm. The thickness of slot insulation is 2 mm, all other insulation may be neglected. The second design is to have 3 slots per pole per phase. Retaining the same flux density in the teeth and current density in the stator conductors as in the first design, calculate the dimensions of the stator slot for the second design. Total height of lip and wedge may be assumed as 5 mm.

**Sln.**

**First Design:**

Slot per pole per phase  $q = 2$

Total height of the conductor =  $75 - 5 - 2 \times 2 = 66 \text{ mm}$

Height of each conductor =  $66 / 9 = 7.33 \text{ mm}$

Width of each conductor =  $19 - 2 \times 2 = 15 \text{ mm}$

Area of each conductor =  $7.33 \times 15 = 110 \text{ mm}^2$

Slot pitch at mean diameter = slot width + tooth width = 19 + 25 = 44 mm

**Second Design:**

Slots per pole per phase = 3

Hence, the number of stator slots in this design are 3/2 times that in the first design.

Retaining the same flux density in the teeth and current density in the stator conductors

The number of conductors per slot in this design is 2/3 times that in the first design.

Number of conductors per slot =  $2/3 \times 9 = 6$

Slot pitch at mean diameter =  $2/3 \times 44 = 29.3$  mm

Tooth width at the same flux density =  $2/3 \times 25 = 16.7$  mm

Hence slot width =  $29.3 - 16.7 = 12.6$  mm

Width of each conductor =  $12.6 - 2 \times 2 = 8.6$  mm

Height of each conductor =  $110/8.6 = 12.8$  mm

Total height of the conductor =  $6 \times 12.8 = 76.8$  mm

Conductor dimensions  $12.8 \times 8.6$  mm<sup>2</sup>

Depth of the slot =  $76.8 + 5 + 2 \times 2 = 85.8$  mm

Slot dimensions =  $85.8 \times 12.6$  mm<sup>2</sup>

**Ex. 5.** A 1000 kVA, 3300 volts, 50 Hz, 300 rpm, 3 phase alternator has 180 slots with 5 conductors per slot. Single layer winding with full pitched coils is used. The winding is star connected with one circuit per phase. Determine the specific electric and magnetic loading if the stator bore is 2 m and core length is 0.4 m. Using the same specific loadings determine the design details for a 1250 kVA, 3300 volts, 50 Hz, 250 rpm, 3 phase star connected alternator having 2 circuits per phase. The machines have 60° phase spread.

**Sln:** Total stator conductors =  $180 \times 5 = 900$

Turns per phase =  $900 / 6 = 150$

Synchronous speed =  $300/60 = 5$  rps

Number of poles =  $120f / N_s = 120 \times 50 / 300 = 20$

Slots per pole per phase =  $180 / (20 \times 3) = 3$

Distribution factor =  $(\sin 60/2) / (3 \sin 60/6) = 0.96$

For Full pitched winding, pitch factor  $k_p = 1$

Winding factor =  $k_p \times k_d = 0.96$

$E_{ph} = 3300/\sqrt{3} = 1910$  volts

Flux per pole =  $1910 / (4.44 \times 50 \times 150 \times 0.96) = 59.8$  mwb

Pole pitch =  $\pi D/p = \pi \times 2 / 20 = 0.314$  m

Area of one pole pitch  $A_p = \text{pole pitch} \times \text{core length} = 0.314 \times 0.4 = 125.6 \times 10^{-3}$  m<sup>2</sup>

Specific magnetic loading =  $\text{Flux} / A_p = 59.8 \times 10^{-3} / 125.6 \times 10^{-3} = 0.476$  Tesla

Current per phase  $I_{ph} = 1000 \times 10^3 / (3 \times 1910) = 175$  amps

As there is one circuit per phase current per conductor = 175 amps

Specific electric loading =  $3 I_{ph} z_{ph} / \pi D = 6 I_{ph} T_{ph} / \pi D = 6 \times 175 \times 150 / (\pi \times 2) = 25000$  Ac/m

Peripheral speed =  $\pi D N_s / 60 = \pi \times 2 \times 300 / 60 = 31.4$  m/s

**1250 kVA generator**

Synchronous speed =  $250/60 = 4.167$  rps

Number of poles =  $120f / N_s = 120 \times 50 / 250 = 24$

Winding factor = 0.96

Output coefficient  $C_0 = 11 B_{av} q K_w \times 10^{-3} = 11 \times 0.476 \times 0.96 \times 25000 \times 10^{-3} = 126$



$$D^2L = Q / C_0 n_s = 1250 / (126 \times 4.167) = 2.39 \text{ m}^3$$

Keeping the peripheral speed same as that of the first machine

$$\pi DN_s/60 = \pi \times D \times 250/60 = 31.4 \text{ m/s}$$

Hence  $D = 2.4 \text{ m}$  and  $L = 0.414 \text{ m}$

$$\text{Pole pitch} = \pi D/p = \pi \times 2.4 / 24 = 0.314 \text{ m}$$

$$\text{Flux per pole} = B_{av} \times \pi DL/p = 0.476 \times 0.314 \times 0.414 = 0.062 \text{ wb}$$

When there are more than one circuit per phase ( number of parallel paths = a)

$$\text{Voltage per phase } E_{ph} = 4.44f \Phi T_{ph} K_w / a; \quad a = 2$$

$$\text{Hence } T_{ph} = (2 \times 1910) / (4.44 \times 50 \times 0.062 \times 0.96) = 289$$

$$\text{Total number of conductors} = 6 T_{ph} = 6 \times 289 = 1734$$

$$\text{Total number of slots} = 3 \times 24 \times 3 = 216$$

$$\text{Number of conductors per slot} = 1734/216 \approx 8$$

$$\text{Revised number of conductors} = 8 \times 216 = 1728$$

$$\text{Revised number of turns per phase} = 1728/6 = 288$$

**Ex. 6.** Determine the main dimensions of a 75 MVA, 13.8 kV, 50 Hz, 62.5 rpm, 3 phase star connected alternator. Also find the number of stator slots, conductors per slot, conductor area and work out the winding details. The peripheral speed should be less than 40 m/s. Assume average gap density as  $0.65 \text{ wb/m}^2$ , Specific electric loading as 40,000 AC/m and current density as  $4 \text{ amp/mm}^2$ .

**Soln:**

$$\text{Synchronous speed} = 62.5/60 = 1.0417 \text{ rps}$$

$$\text{Number of poles} = 120f / N_s = 120 \times 50 / 62.5 = 96$$

$$\text{Winding factor} = 0.955$$

$$\text{Output coefficient } C_0 = 11 B_{av} q K_w \times 10^{-3} = 11 \times 0.65 \times 0.955 \times 40000 \times 10^{-3} = 273$$

$$D^2L = Q / C_0 n_s = 75000 / (273 \times 1.0417) = 264 \text{ m}^3$$

Taking the peripheral speed as 40 m/s

$$\text{Peripheral speed} = \pi DN_s/60$$

$$\text{Hence } D = 40 \times 60 / \pi \times 300 = 12.2 \text{ m} \text{ and } L = 1.77 \text{ m}$$

$$\text{Pole pitch} = \pi D/p = \pi \times 12.2 / 96 = 0.4 \text{ m}$$

$$\text{Flux per pole} = B_{av} \times \pi DL/p = 0.65 \times 0.4 \times 1.77 = 0.46 \text{ wb}$$

$$E_{ph} = 13800/\sqrt{3} = 7960 \text{ volts}$$

Assuming one circuit per phase

$$\text{Turns per phase } T_{ph} = E_{ph} / 4.44f \Phi K_w = 7960 / (4.44 \times 50 \times 0.46 \times 0.955) \approx 82$$

As the terminal voltage of the machine is 13.8 kV slot pitch of about 5.5 cm should be used.

$$\text{Hence the number of slots} = \pi D / \tau_s = \pi \times 12.2 \times 100/5.5 = 696$$

$$\text{Number of slots per pole per phase} = S/3p = 696 / (3 \times 96) = 2.42$$

The above fractional value of slots per pole per phase indicates that fractional slot winding is used. Number of slots and turns per phase must be finalized such that they should not differ significantly from the earlier calculated values.

It is also to be noted that for fractional slot winding double layer winding is a must and hence conductors per slot must be an even.

Assuming number of slots per pole per phase as 2.5

$$\text{Total number of slots} = 2.25 \times 3 \times 96 = 648$$

$$\text{Total number of conductors} = 2 \times 3 \times T_{ph} = 6 \times 82 = 492$$

$$\text{Hence number of conductors per slot} = 492/648 = \text{fraction}$$

Hence a double layer winding is not possible with one circuit per phase. Hence the number of circuits is to be selected in such a way that number of conductors per slot is even and the winding becomes symmetrical.

Taking the number parallel circuits as  $a = 8$

$$\text{Turns per phase } T_{ph} = a \times E_{ph} / 4.44f \Phi K_w = 8 \times 7960 / (4.44 \times 50 \times 0.46 \times 0.955) \approx 654$$

$$\text{Hence total number of conductors} = 2 \times 3 \times T_{ph} = 6 \times 654 = 3924$$

$$\text{Number of conductors per slot} = 3924 / 648 \approx 6$$

$$\text{Hence the number of conductors} = 6 \times 648 = 3888$$

$$\text{Hence turns per phase } T_{ph} = 3888 / 6 = 648$$

$$\text{Current per phase} = (75000 \times 10^3) / (3 \times 7960) = 3140 \text{ amps}$$

$$\text{Current in each conductor} = \text{Current per parallel path} = 3140 / 8 = 392.5 \text{ amps}$$

$$\text{Area of cross section of each conductor} = 392.5 / 4 = 98.125 \text{ mm}^2$$

Area of cross section of conductor being very large conductors are stranded and used.

**Ex.7.** Calculate the stator dimensions for 5000 kVA, 3 phase, 50 Hz, 2 pole alternator. Take mean gap density of 0.5 wb/m<sup>2</sup>, specific electric loading of 25,000 ac/m, peripheral velocity must not exceed 100 m/s. Air gap may be taken as 2.5 cm.

$$\text{Soln: Output } Q = Co D^2 L ns \text{ kVA}$$

$$Co = 11 B_{av} q K_w \times 10^{-3}$$

$$\text{Assuming } K_w = 0.955$$

$$Co = 11 \times 0.5 \times 25000 \times 0.955 \times 10^{-3} \\ = 130$$

$$Ns = 120f/p = 120 \times 50 / 2 = 3000$$

$$ns = 3000 / 60 = 50 \text{ rps}$$

$$D^2 L = Q / Co ns$$

$$= 5000 / (130 \times 50)$$

$$= 0.766 \text{ m}^3$$

$$\text{Peripheral velocity} = \pi D r Ns / 60 \\ = 100 \text{ m/s}$$

$$D r = 100 / (50 \times \pi)$$

$$= 63.5 \text{ cm}$$

$$D = D r + 2l_g$$

$$= 63.5 + 2 \times 2.5$$

$$= 68.5 \text{ cm}$$

$$L = 163 \text{ cm}$$

Numerical Problems: Turbo alternators

**Ex.1.** Calculate the stator dimensions for 5000 kVA, 3 phase, 50 Hz, 2 pole alternator. Take mean gap density of 0.5 wb/m<sup>2</sup>, specific electric loading of 25,000 ac/m, peripheral velocity must not exceed 100 m/s. Air gap may be taken as 2.5 cm.

$$\text{Soln: Output } Q = Co D^2 L ns \text{ kVA}$$

$$C_o = 11 B_{av} q K_w \times 10^{-3}$$

Assuming  $K_w = 0.955$

$$C_o = 11 \times 0.5 \times 25000 \times 0.955 \times 10^{-3} \\ = 130$$

$$N_s = 120f/p = 120 \times 50 / 2 = 3000 \text{ rpm}$$

$$n_s = 3000/60 = 50 \text{ rps}$$

$$D^2L = Q / \text{Cons}$$

$$= 5000 / (130 \times 50)$$

$$= 0.766 \text{ m}^3$$

$$\text{Peripheral velocity} = \pi D r N_s / 60$$

$$= 100 \text{ m/s}$$

$$D_r = 100 / (50 \times \pi)$$

$$= 63.5 \text{ cm}$$

$$D = D_r + 2l_g$$

$$= 63.5 + 2 \times 2.5$$

$$= 68.5 \text{ cm}$$

$$L = 163 \text{ cm}$$

Ex.2. A 3000 rpm, 3 phase, 50 Hz, turbo alternator

Has a core length of 0.94 m. The average gap density

is 0.45 Tesla and the ampere conductors per m are 25000. The peripheral speed of the rotor is 100 m/s and the length of the air gap is 20mm. Find the kVA output of the machine when the coils are (i) full pitched (ii) short chorded by 1/3rd pole pitch. The winding is infinitely distributed with a phase spread of 60°.

Soln:

$$\text{Synchronous speed } N_s = 3000 \text{ rpm}$$

$$n_s = 3000/60 = 50 \text{ rps}$$

$$\text{Peripheral speed } n_p = \pi D r N_s / 60$$

$$= 100 \text{ m/s}$$

$$\text{Hence diameter of the rotor } D_r = 100 \times 60 / (\pi \times 3000)$$

$$= 0.637 \text{ m}$$

$$\text{Hence inner diameter of stator } D = D_r + 2l_g$$

$$= 0.637 + 2 \times 0.02$$

$$= 0.677 \text{ m}$$

(i) With infinite distribution and 60° phase spread the distribution factor may be given by where  $\alpha$  is the phase spread

$$K_d = \sin \sigma/2 / \sigma/2 = \sin \pi/6 / \pi/6 = 0.955$$

With full pitched coils  $K_p = 1$

$$\text{Winding factor} = K_p \times K_d = 0.955$$

$$\text{Output of the machine } Q = C_o D^2 L n_s$$

$$= 11 B_{av} q K_w \times D^2 L n_s \times 10^{-3}$$

$$= 11 \times 0.45 \times 25000 \times 0.955 \times 0.6672 \times 0.94 \times 50 \times 10^{-3}$$

$$= 2480 \text{ kVA}$$

(ii) With chording of 1/3rd of pole pitch:

chording angle  $\alpha = 180/3 = 60^\circ$

Pitch factor =  $\cos \alpha / 2 = 0.866$

Winding factor =  $K_p \times K_d = 0.955 \times 0.866 = 0.827$

Output of the machine  $Q = C_0 D^2 L n_s$

$$= 11 B_{av} q K_w \times D^2 L n_s \times 10^{-3}$$

$$= 11 \times 0.45 \times 25000 \times 0.827 \times 0.6672 \times 0.94 \times 50 \times 10^{-3}$$

$$= 2147 \text{ kVA}$$

Ex. 3. Estimate the stator dimensions, size and number

of conductors and number of slots of 15 MVA 11kV,

3 phase, 50 Hz, 2 pole turbo alternator with 60° phase spread.

Assume Specific electric loading = 36000 AC/m, specific magnetic loading = 0.55 Tesla,

Current density = 5 Amp/mm<sup>2</sup>, peripheral speed = 160 m/s. The winding must be designed to eliminate 5th harmonic.

Soln: Synchronous speed  $N_s = 120f/p = 120 \times 50 / 2 = 3000 \text{ rpm}$

$$n_s = 3000/60 = 50 \text{ rps}$$

Peripheral speed  $v_p = \pi D r N_s / 60$

$$= 160 \text{ m/s}$$

Hence diameter of the rotor  $D_r \approx D$

$$= 160 \times 60 / (\pi \times 3000)$$

$$= 1 \text{ m}$$

With a phase spread of 60° distribution factor

$$K_d = \sin \sigma/2 / \sigma/2 = \sin \pi/6 / \pi/6 = 0.955$$

In order to eliminate 5th harmonic chording angle  $\alpha = 180/5 = 36^\circ$

$$\text{Pitch factor } K_p = \cos \alpha / 2 = 0.951$$

$$\text{Winding factor} = K_p \times K_d = 0.955 \times 0.951 = 0.908$$

Output coefficient  $C_0 = 11 B_{av} q K_w \times 10^{-3}$

$$= 11 \times 0.55 \times 36000 \times 0.908 \times 10^{-3}$$

$$= 198$$

$$D^2 L = Q / C_0 n_s$$

$$= 15000 / (198 \times 50) = 1.51 \text{ m}^3$$

We have  $D = 1 \text{ m}$  and  $D^2 L = 1.51 \text{ m}^3$

Solving for L,  $L = 1.51 \text{ m}$

Flux per pole =  $B_{av} \times \pi D L / p$

$$= 0.55 \times \pi \times 1 \times 1.51 / 2$$

$$= 1.3 \text{ wb}$$

$$E_{ph} = 1100 / \sqrt{3} = 6360 \text{ volts}$$

Hence  $T_{ph} = E_{ph} / 4.44 f \Phi K_w$

$$= 6360 / (4.44 \times 50 \times 1.3 \times 10^{-3} \times 0.908)$$

$$= 24$$

Total number of conductors =  $6 \times 24$

$$= 144$$

For the turbo alternator selecting slots/pole/phase = 5

Total number of stator slots =  $5 \times 2 \times 3 = 30$

Conductors/slot =  $144 / 30 = 5$

can not use double layer winding,  
using two circuits per phase  
conductors/slot = 10

Total conductors  $10 \times 30 = 300$ .

### Design of the field System: Salient pole Alternator:

#### Dimension of the pole:

- (i) Axial Length of the pole: Axial length of the pole may be assumed 1 to 1.5 cm less than that of the stator core.
- (ii) Width of the pole: Leakage factor for the pole is assumed varying between 1.1 to 1.15. Thus the flux in the pole body = 1.1 to 1.15

Area of the pole = Flux in the pole body / Flux density in the pole body.

Flux density in the pole body is assumed between 1.4 to 1.6 wb/m<sup>2</sup>.

Area of the pole = width of the pole x net axial length of the pole.

Net axial length of the pole = gross length x stacking factor

Stacking factor may be assumed as 0.93 to 0.95.

Hence width of the pole = Area of the pole / net axial length of the pole.

- (iii) Height of the pole:

Height of the pole is decided based on the mmf to be provided on the pole by the field winding at full load. Hence it is required to find out the mmf to be provided on the pole at full load before finding the height of the pole. Full load field ampere turns required for the pole can be calculated based on the armature ampere turns per pole.

Hence full load field ampere turns per pole can be assumed 1.7 to 2.0 times the armature ampere turns per pole.

Armature ampere turns per pole  $AT_a = 1.35 I_{ph} T_{ph} K_w / p$

And

$$AT_f = (1.7 \text{ to } 2.0) AT_a$$

Height of the pole is calculated based on the height of the filed coil required and the insulation.

Height of the filed coil:

$I_f$  = current in the field coil

$a_f$  = area of the field conductor

$T_f$  = number of turns in the field coil

$R_f$  = resistance of the field coil

$l_{mt}$  = length of the mean turn of the field coil

$s_f$  = copper space factor  
 $h_f$  = height of the field coil  
 $d_f$  = depth of the field coil  
 $p_f$  = permissible loss per  $m^2$  of the cooling surface of the field coil  
 $\zeta$  = specific resistance of copper

Watts radiated from the field coil = External surface in  $cm^2$  x watts/ $cm^2$   
 = External periphery of the field coil x Height of the field coil x watts/ $cm^2$

Total loss in the coil =  $(I_f^2 \times R_f) = (I_f^2 \times \zeta \times l_{mt} \times T_f / a_f)$   
 Total copper area in the field coil =  $a_f \times T_f = s_f h_f d_f$

Hence  $a_f = s_f d_f h_f / T_f$

Thus watts lost per coil =  $(I_f^2 \times \zeta \times l_{mt} \times T_f) T_f / s_f h_f d_f$   
 =  $(I_f T_f)^2 \zeta \times l_{mt} / s_f h_f d_f$

Loss dissipated from the field coil =  $q_f$  x cooling surface of the field coil

Normally inner and outer surface of the coils are effective in dissipating the heat. The heat dissipated from the top and bottom surfaces are negligible.

Cooling surface of the field coil =  $2 \times l_{mt} \times h_f$

Hence loss dissipated from the field coil =  $2 \times l_{mt} \times h_f \times q_f$

For the temperature rise to be within limitations

Watts lost per coil = watts radiated from the coil

$(I_f T_f)^2 \zeta \times l_{mt} / s_f h_f d_f = 2 \times l_{mt} \times h_f \times q_f$

Hence  $h_f = (I_f T_f) / [10^4 \times \sqrt{(s_f d_f q_f)}]$   
 =  $AT_{fl} \times 10^{-4} / \sqrt{(s_f d_f q_f)}$

Depth of the field coil is assumed from 3 to 5 cm,  
 Copper space factor may be assumed as 0.6 to 0.8,  
 Loss per  $m^2$  may be assumed as 700 to 750  $w/m^2$

Hence the height of the pole =  $h_f$  + height of the pole shoe + height taken by insulation

### Design of field winding for salient pole Alternator:

Design of the field winding is to obtain the following information.

- (i) Cross sectional area of the conductor of field winding
- (ii) Current in field winding

- (iii) Number of turns in field winding
- (iv) Arrangement of turns
- (v) Resistance of the field winding
- (vi) Copper loss in the field winding

Above informations can be obtained following the following steps

- (i) Generally the exciter voltage will be in the range of 110 volts to 440 volts. 15-20 % of voltage is kept as drop across the field controller.  
Hence voltage per coil  $V_c = (0.8 \text{ to } 0.85) \text{ exciter voltage} / \text{Number of field coils}$
- (ii) Assume suitable value for the depth of the field coil
- (iii) Mean length of the turn in field coil is estimated from the dimensions of the pole and the depth of the field windings. Mean length of the turn  $= 2(l_p + b_p) + \pi(d_f + 2t_i)$  where  $t_i$  is the thickness of insulation on the pole.
- (iv) Sectional area of the conductor can be calculated as follows

Resistance of the field coil  $R_f = \zeta \times l_{mt} \times T_f / a_f = \text{voltage across the coil} / \text{field coil}$

$$V_c / I_f = \zeta \times l_{mt} \times T_f / a_f$$

$$\text{Hence } a_f = \zeta \times l_{mt} \times I_f T_f / V_c$$

- (v) Field current can be estimated by assuming a suitable value of current density in the field winding. Generally the value of current density may be taken as 3.5 to 4 amp/mm<sup>2</sup>.  
Hence  $I_f = \delta_f \times a_f$
- (vi) Number of turns in the field winding  $T_f = \text{Full load field ampere turns} / \text{field current} = AT_f / I_f$
- (vii) Height of the field winding  $h_f = AT_f \times 10^{-4} / \sqrt{(s_f d_f q_f)}$
- (viii) Resistance of the field winding  $R_f = \zeta \times l_{mt} \times T_f / a_f$
- (ix) Copper loss in the field winding  $= I_f^2 \times R_f$

### Numerical Problems on Field System Design of Salient pole machines:

**Ex.1.** The following information has been obtained during the preliminary design of a 3 phase 500 kVA, 6.6 kV, 12 pole, 500 rpm, star connected salient pole alternator.

Stator diameter = 1.3 m, gross length of stator = 0.21m, air gap flux per pole = 0.0404 wb

Based on the above information, design the field system of the alternator giving the following details.

- (i) Length of the air gap
- (ii) Diameter of the rotor at the air gap surface
- (iii) Dimension of the pole

**Soln:**

$$\begin{aligned} \text{(i) Length of the air gap : Air gap flux per pole} &= B_{av} \times \pi DL/p \\ &= (12 \times 0.0404) / (\pi \times 1.3 \times 0.21) \\ &= 0.56 \text{ Tesla} \end{aligned}$$

$$\text{We have } AT_{f0} = SCR \times AT_a \text{ and } AT_a = 1.35 I_{ph} T_{ph} K_w / p$$

$$\text{We have } Eph = 4.44 f T_{ph} kw \text{ and}$$

$$\text{Hence } T_{ph} \times K_w = E_{ph} / (4.44 f) = 6600 / \sqrt{3} / (4.44 \times 50 \times 0.0404) = 424$$

$$\text{Full load current} = 500 \times 10^3 / \sqrt{3} \times 6600 = 43.7 \text{ amps}$$

$$AT_a = 1.35 I_{ph} T_{ph} K_w / p = 1.35 \times 43.7 \times 424 / 6 = 4169 \text{ AT}$$

$$\text{Assuming a short circuit ratio of 1.1 } AT_{f0} = SCR \times AT_a = 1.1 \times 4169 = 4586 \text{ AT}$$

Assuming AT required for the air gap as 70 % of the no load field ampere turns per pole

$$AT_g = 0.7 \times AT_{f0} = 0.7 \times 4586 = 3210 \text{ AT}$$

Assuming Carter's coefficient for the air gap  $k_g$  as 1.15 and field form factor  $K_f$  as 0.7

$$B_g = B_{av} / K_f = 0.56 / 0.7 = 0.8 \text{ Tesla}$$

We have air gap ampere turns  $AT_g = 796000 B_g k_g l_g$

$$\text{Hence air gap length } l_g = 3210 / (796000 \times 0.8 \times 1.15) = 0.0044 \text{ m} = 4.4 \text{ mm}$$

$$(ii) \text{ Diameter of the rotor } D_r = D - 2 l_g = 1.2 - 2 \times 0.0044 = 1.191 \text{ m}$$

$$(iv) \text{ Peripheral speed} = \pi D_r N_s / 60 = \pi \times 1.191 \times 500 / 60 = 31.2 \text{ m/s}$$

(v) Dimensions of the pole : Assuming the axial length as 1 cm less than that of the gross length of the stator

$$(a) \text{ Axial length of the pole } L_p = 0.21 - 0.01 = 0.2 \text{ m}$$

(b) Width of the pole: Assuming the leakage factor for the pole as 1.15

$$\text{Flux in the pole body } \Phi_p = 1.15 \times 0.0404 = 0.0465 \text{ wb}$$

Assuming flux density in the pole body as 1.5 Tesla

$$\text{Area of the pole} = 0.0465 / 1.5 = 0.031 \text{ m}^2$$

Assuming a stacking factor of 0.95

$$\text{Width of the pole} = \text{area of the pole} / \text{stacking factor} \times L_p = 0.031 / (0.95 \times 0.2) = 0.16 \text{ m}$$

Height of the pole: Assuming  $AT_{fl} = 1.8 \times AT_a = 1.8 \times 4169 = 7504 \text{ AT}$

Assuming : Depth of the field coil = 4 cm

Space factor for the filed coil = 0.7

Permissible loss per unit area = 700 w/m<sup>2</sup>

$$\begin{aligned} \text{Height of the filed coil } h_f &= (I_f T_f) / [10^4 \times \sqrt{(s_f d_f q_f)}] \\ &= 7504 / [10^4 \times \sqrt{(0.04 \times 0.7 \times 700)}] \\ &= 0.17 \text{ m} \end{aligned}$$

Hence the height of the pole =  $h_f$  + height of the pole shoe + height taken by insulation

Assuming height of the pole shoe + height taken by insulation as 0.04 m

$$\text{Height of the pole} = 0.17 + 0.04 = 0.21 \text{ m}$$

**Ex.2.** The field coils of a salient pole alternator are wound with a single layer winding of bare copper strip 30 mm deep, with a separating insulation of 0.15 mm thick. Determine a suitable winding length, number of turns and thickness of the conductor to develop an mmf of 12000 AT with a potential difference of 5 volts per coil and with a loss of 1200 w/m<sup>2</sup> of total coil surface. The mean length of the turn is 1.2 m. The resistivity of copper is 0.021 Ω/m and mm<sup>2</sup>.

$$\begin{aligned} \text{Soln. Area of field conductor } a_f &= \zeta \times (I_f T_f) / V_c \\ &= 0.021 \times 1.2 \times 12000 / 5 \\ &= 60.4 \text{ mm}^2 \end{aligned}$$

$$\text{Hence height of the conductor} = 60.4 / 30 = 2 \text{ mm}$$

$$\text{Revised area of the conductor} = 60 \text{ mm}^2$$

$$\begin{aligned} \text{Total heat dissipating surface } S &= 2 \times l_{mt} (h_f + d_f) \\ &= 2 \times 1.2 (h_f + 0.03) \\ &= 2.4 h_f + 0.072 \text{ m}^2 \end{aligned}$$



Hence total loss dissipated  $Q_f = 1200 (2.4 h_f + 0.072)$  watts  
 $= 2880 h_f + 86.4$  watts

Field current  $I_f = Q_f/v_c = (2880 h_f + 86.4)/5 = 5.76 h_f + 17.3$

And  $I_f T_f = (5.76 h_f + 17.3) T_f = 12000$

$I_f T_f = 5.76 h_f T_f + 17.3 T_f = 12000$

Height occupied by the conductor including insulation  $= 2 + 0.15 = 2.15$  mm

Hence height of the field winding  $h_f = T_f \times 2.15 \times 10^{-3}$

Substituting this value in the expression for  $I_f T_f$  we get

$$I_f T_f = 5.76 \times T_f \times 2.15 \times 10^{-3} T_f + 17.3 T_f = 12000$$

Solving for  $T_f$ ,  $T_f = 91$

Hence height of the field winding  $= 2.15 \times 91 = 196$  mm

**Ex. 3** Design the field coil of a 3 phase, 16 pole, 50 Hz, salient pole alternator, based on the following design information. Diameter of the stator = 1.0 m, gross length of the stator = 0.3 m, section of the pole body = 0.15 m x 0.3 m, height of the pole = 0.15 m, Ampere turns per pole = 6500, exciter voltage = 110 volts, Assume missing data suitably.

**Soln.** Sectional area of the conductor:

Assuming 30 volts as reserve in field regulator

$$V_c = 110 - 30 / 16 = 5 \text{ volts}$$

Assuming depth of the field coil = 3 cm, thickness of insulation = 1 cm

Mean length of the turn  $= 2(l_p + b_p) + \pi(d_f + 2t_i) = 2(0.3 + 0.15) + \pi(0.03 + 2 \times 0.01) = 1.05$  m

$$\text{Sectional area of the conductor } a_f = \zeta \times l_{mt} \times I_f T_f / V_c \\ = (0.021 \times 1.05 \times 6000)/5 = 28.66 \text{ mm}^2$$

Standard size of the conductor available = 28.5 mm<sup>2</sup> with the size 16 mm x 1.8 mm

Assuming an insulation thickness of 0.5 mm over the conductor

size of the conductor = 16.5 mm x 2.3 mm

Assuming an insulation of 2mm between the layers

Actual depth of the field winding  $= 16.5 + 2 + 16.5 = 35$  mm or 3.5 cm

Field current: Assuming a current density of 2.6 amps/mm<sup>2</sup>

Field current  $I_f = a_f \times \delta_f = 28.5 \times 2.6 = 74$  amps

Number of turns:  $T_f = I_f T_f / I_f = 6000/74 = 88$  turns

Arrangement of turns: As decided above 88 turns are arranged in two layers with 44 turns in each layer. Height of each field turn = 2.3 mm

Hence height of the field coil  $= 44 \times 2.3 = 10.1$  cm

As height of the pole is 15 cm, height of the field coil is satisfactory.

$$\text{Resistance of the field coil } R_f = \zeta \times l_{mt} \times T_f / a_f \\ = 0.021 \times 1.05 \times 88 / 28.5 \\ = 0.068 \Omega$$

Filed Copper loss:  $I_f^2 R_f = 74^2 \times 0.068 = 372$  watts

Total field cu loss  $= 16 \times 372 = 5.95$  kW.

**Ex.4.** Design the field coil of a 500 rpm, 3 phase, 50 Hz alternator having the following design data.

Diameter of stator = 95 cm, Core length = 30 cm, Pole body = 10 cm x 30 cm, Field ampere turns = 6000, Excitation voltage = 80 volts. Heat dissipation from the outer surface = 0.35 watts/cm<sup>2</sup>. Assume missing data suitably.

**Soln:** Area of the field coil:

Number of field coils or poles =  $120f/N_s = 120 \times 50 / 500 = 12$

Assuming 20 volts in the field regulator

Voltage per coil =  $80 - 20 / 12 = 5$  volts

Ampere turns /pole = 6000

Pole body = 10 cm x 30 cm,

Assuming depth of the field coil = 3 cm,

Thickness of insulation = 1 cm

Mean length of the turn =  $2(l_p + b_p) + \pi(d_f + 2t_i)$   
 $= 2(0.3 + 0.1) + \pi(0.03 + 2 \times 0.01) = 0.957$  m

Sectional area of the conductor  $a_f = \zeta \times l_{mt} \times I_f T_f / V_c$   
 $= (0.021 \times 0.957 \times 6000) / 5 = 24.2$  mm<sup>2</sup>

Standard size of the conductor available 14.2 mm x 1.7 mm

Assuming an insulation thickness of 0.5 mm over the conductor

Assuming an insulation of 1.6 mm between the layers

Actual depth of the field winding =  $14.2 + 1.6 + 14.2 = 3.0$  cm

Number of turns: Heat dissipation from the outer surface = 0.35 watts/cm<sup>2</sup>

Area of the outer surface of the field coil =  $(l_{mt} + \pi d_f) h_f = (95.7 + \pi \times 3) h_f$   
 $= 105.1 h_f$  cm<sup>2</sup>

Hence heat dissipated =  $0.35 \times 105.1 h_f = 36.8 h_f = V_c \times I_f$   
 $= V_c \times I_f T_f / T_f$

Hence  $36.8 h_f = V_c \times I_f T_f / T_f$   
 $= 5 \times 6000 / T_f$

Hence  $h_f T_f = 5 \times 6000 / 36.8 = 815$

Assuming an insulation thickness of 0.15 mm between the conductors

Height of each conductor = Height of conductor + insulation  
 $= 1.7 + 0.15 = 1.85$  mm = 0.185 cm

Assuming that the turns are arranged in two layers

Height of turns / layer  $h_f = 0.185 \times T_f / 2$

Hence  $h_f T_f = 0.185 \times T_f / 2 \times T_f = 815$   
 $T_f = 94$

Hence height of the field coil  $h_f = 0.185 \times T_f / 2 = 0.185 \times 94 / 2 = 8.7$  cm

Field current  $I_f = 6000 / 94 = 64$  amps

Resistance of the field coil  $R_f = \zeta \times l_{mt} \times T_f / a_f$   
 $= 0.021 \times 0.957 \times 94 / 24.2$   
 $= 0.078$   $\Omega$

Filed Copper loss:  $I_f^2 R_f = 64^2 \times 0.078 = 320$  watts

Total field cu loss =  $12 \times 320 = 3.84$  kW.

**Design of the field System: NonSalient pole Alternator:**

In case of turbo alternators, the rotor windings or the field windings are distributed in the rotor slots. The rotor construction of the turbo alternator is as shown in fig. below.

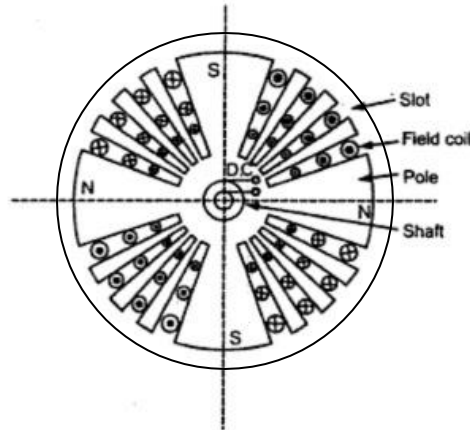

Normally 70% of the rotor is slotted and remaining portion is unslotted in order to form the pole. The design of the field can be explained as follows.

(i) Selection of rotor slots: Total number of rotor slots may be assumed as 50 – 70 % of stator slots pitches. However the so found rotor slots must satisfy the following conditions in order to avoid the undesirable effects of harmonics in the flux density wave forms.

- (a) There should be no common factor between the number of rotor slot pitches and number of stator slot pitches.
- (b) Number of wound rotor slots should be divisible by 4 for a 2 pole synchronous machine. That means the number of rotor slots must be multiple of 4.
- (c) Width of the rotor slot is limited by the stresses developed at the rotor teeth and end rings.

(ii) Design of rotor winding

(a) Full load field mmf can be taken as twice the armature mmf.

$$AT_{fl} = 2 \times AT_a = 2 \times 1.35 \times I_{ph} \times T_{ph} \times k_w / p$$

(b) Standard exciter voltage of 110 - 220 volts may be taken. With 15-20 % of this may be reserved for field control. Hence voltage across each field coil  $V_f = (0.8 \text{ to } 0.85) V/p$

(c) Length of the mean turn  $l_{mt} = 2L + 1.8 \tau_p + 0.25 \text{ m}$

(d) Sectional area of each conductor  $a_f = \zeta \times l_{mt} \times (I_f \times T_f) / v_f$

(e) Assume suitable value of current density in the rotor winding. 2.5 – 3.0 amp/mm<sup>2</sup> for conventionally cooled machines and 8 – 12 amp/mm<sup>2</sup> for large and special cooled machines.

(f) Find area of all the rotor conductors per pole =  $2 \times (I_f \times T_f) / \delta_f$

(g) Find the number of rotor conductors per pole =  $2 \times (I_f \times T_f) / (\delta_f \times a_f)$

(h) Number of field conductors per slot =  $2 \times (I_f \times T_f) / (\delta_f \times a_f \times s_r)$ , where  $s_r$  is the number of rotor slots.

(i) Resistance of each field coil  $R_f = \zeta \times l_{mt} \times T_f / a_f$

(j) Calculate the current in the field coil  $I_f = v_f / R_f$

Based on the above data dimensions may be fixed. The ratio of slot depth to slot width may be taken between 4 and 5. Enough insulation has to be provided such that it with stands large amount of mechanical stress and the forces coming on the rotor.

The following insulation may be provided for the field coil.

(i) All field conductors are provided with mica tape insulation.

- (ii) Various turns in the slots are separated from each other by 0.3 mm mica separators.
- (iii) 0.5 mm hard mica cell is provided on all the field coil.
- (iv) Over the above insulation, 1.5 mm flexible mica insulation is provided.
- (v) Lastly a steel cell of 0.6 mm is provided on the whole field coil.

Ex. 1. Design the rotor of a 3 phase 20 MVA, 11 kV, 3000 rpm, 50 Hz, turbo alternator with the following design data. Diameter at the air gap = 0.8 m, Gross length = 2.4 m, stator turns per phase = 18, Number of stator slots = 36, Exciter voltage = 220 volts, Estimate (i) Number of rotor slots, (ii) area of the field conductor (iii) Turns in the filed coil and (iv) Field current

Soln: (i) Number of rotor slots : Selection of rotor slots: Total number of rotor slots may be assumed as 50 – 70 % of stator slots. Normally 70% of the rotor is slotted and remaining portion is unslotted.

Number of stator slots = 36

Hence number of slots pitches must be between 18 to 26

Satisfying the conditions number of rotor slot pitches = 23

Number of wound slots = 16

(ii) Area of the field conductor

Assuming 40 volts in the field regulator voltage across filed coil =  $220 - 40 / 2 = 90$  volts

Armature ampere turns /pole  $AT_a = 1.35 I_{ph} T_{ph} K_w / p$

$$= 1.35 \times 1050 \times 18 \times 0.955 / 1 = 24300 \text{ AT}$$

Assuming full load field ampere turns/pole =  $2 \times AT_a = 2 \times 24300 = 48600 \text{ AT}$

Mean length of the turn is given by  $l_{mt} = 2L + 1.8 \tau_p + 0.25 \text{ m}$

$$= 2 \times 2.4 + 1.8 \times 1.256 + 0.25$$

$$= 7.31 \text{ m}$$

Area of the field conductor  $a_f = \zeta \times l_{mt} \times (I_f \times T_f) / v_f$

$$= 0.021 \times 7.31 \times 48600 / 90$$

$$= 83.22 \text{ mm}^2$$

(iii) Number of field turns : Full load field ampere turns/pole = 48600 AT

Full load field ampere conductors/pole =  $2 \times 48600 \text{ AT}$

Assuming a current density of  $2.6 \text{ amp/mm}^2$

Area of all the rotor conductors =  $2 \times 48600 / 2.6 = 37400 \text{ mm}^2$

Number of rotor conductors/pole =  $37400 / 84 = 445$

Number of wound slots per pole =  $16 / 2 = 8$

Number of conductors per slot =  $445 / 8 = 56$

Modified value of conductors per pole =  $56 \times 8 = 448$

Number of field turns per pole  $T_f = 448 / 2 = 224$

Number of coils per pole =  $8 / 2 = 4$

(iv) Field current: Resistance of the field coil  $R_f = \zeta \times l_{mt} \times T_f / a_f$

$$= 0.021 \times 7.31 \times 224 / 84$$

$$= 0.41 \Omega$$

Current in the field winding  $I_f = V / R_f = 90 / 0.41 = 219 \text{ Amps}$ .

## References

1. A Course in Electrical Machine Design – A. K. Sawhney
2. Design of Electrical Machines – V. N. Mittle
3. Performance and Design of A C Machines – M G Say
4. Design and Testing of Electrical Machines – M. V. Deshapande
5. Electrical Machine Design Data Book – Shanmugsundaram and Palani
6. [www.google.com](http://www.google.com) and related websites
7. [www.phasemotorparts.com](http://www.phasemotorparts.com)
8. [www.wikipedia.org](http://www.wikipedia.org)
9. Krishna Vasudevan et. al. Electrical Machines II, Indian Institute of Technology, Madras