



Name :
Roll No. :
Invigilator's Signature :

CS/B.TECH(OLD)/SEM-2/EE-201/2012

2012

BASIC ELECTRICAL ENGINEERING

Time Allotted : 3 Hours

Full Marks : 70

The figures in the margin indicate full marks.

*Candidates are required to give their answers in their own words
as far as practicable.*

GROUP – A

(Multiple Choice Type Questions)

1. Choose the correct answers for any *ten* of the following :

10 × 1 = 10

- i) Value of absolute permittivity (ϵ) of air is
 - a) 1
 - b) 8.854×10^{-12} F/m
 - c) none of these.
- ii) Charge Q is uniformly distributed on the surface of a sphere of radius R . What will be the potential at the centre of the sphere ?
 - a) Zero
 - b) $Q/(4\pi \epsilon_0 \epsilon_r R)$
 - c) None of these.
- iii) The form factor of a sinusoidal wave is always equals to
 - a) 0.5
 - b) 0.707
 - c) 1.414
 - d) 1.11.



- x) An air gap is usually inserted in a magnetic circuit to
- a) Prevent saturation b) Increase the flux
 c) Increase the MMF d) Decrease the flux.
- xi) A D.C. voltage of 100V is applied in a circuit of resistance 100 ohms and inductance 50 henry. The expression of current in the circuit is
- a) $1 - e^{-t}$ b) $1 - e^{-2t}$
 c) $1 + e^{-2t}$ d) $1 - e^{-0.5t}$.
- xii) The output power is maximum for a D.C Motor when
- a) $E_b = V/2$ b) $E_b = 0.5 I_a R_a$
 c) $E_b = V$ d) $E_b = I_a R_a$.

GROUP - B

(Short Answer Type Questions)

Answer any *three* of the following. $3 \times 5 = 15$

2. A resistance of 20Ω , an inductance of 0.2H and capacitor of $100\mu\text{F}$ are connected in series across 220V, 50Hz supply. Determine the following :
- a) Impedance b) Current c) Voltage across R, L, C
 d) Power factor angle e) Real and watt-less Power. 5
3. a) Why are field coils provided in a D.C. machine ?
 b) Why is the armature core of a D.C generator laminated ?



- c) A 4-pole wave wound generator is rotated at a speed of 1000 rpm. The generator has 60 slots and each slot contains 10 No. of conductors. Find the e.m.f generated by this machine when effective field flux per pole is 50mWb. 1 + 1 + 3
4. Develop the exact equivalent circuit of a single phase two winding transformer at no-load. 5
5. State and explain briefly the Biot-Savart's law applicable to electromagnetism. 5
6. A ring having a mean diameter of 21cm and a cross-section of 10 cm² is made of two semicircular sections of cast iron and cast steel respectively with each joint having reluctance equal to air gap of 0.2 mm as shown in figure. Determine the ampere turns required to produce a flux of 0.8mWb. The relative permeability of cast iron and cast steel are 166 and 800 respectively. Neglect fringing and leakage effects. 5

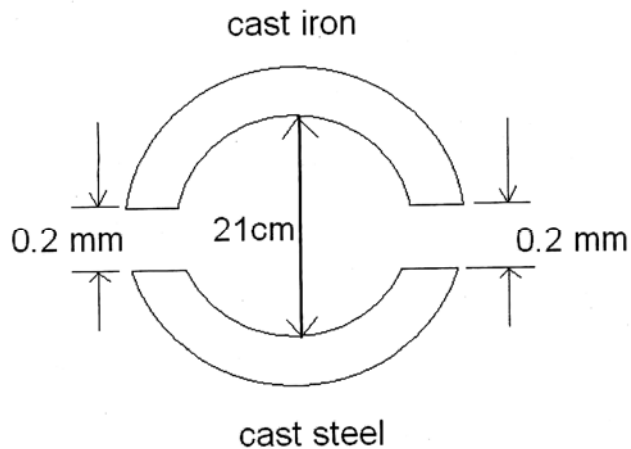



GROUP - C

(Long Answer Type Questions)

Answer any *three* of the following. $3 \times 15 = 45$

7. Solve the network as shown in the following figure for the current flowing through 8Ω resistor by various methods as noted below :

- a) Superposition Theorem
- b) Loop method using KVL
- c) Thevenin's Theorem.

$5 + 5 + 5$

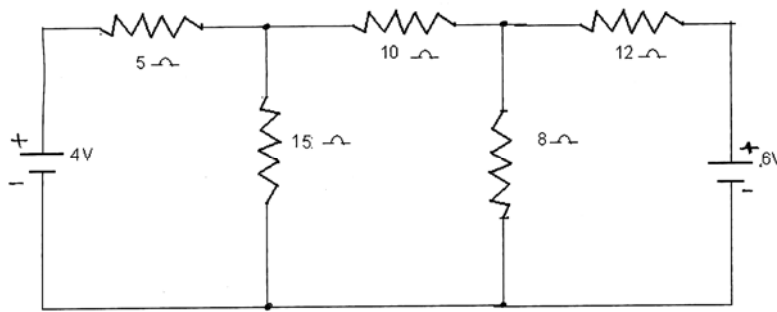

8. a) Find the value of R_L for which the power transfer across R_L is maximum and find the value of the maximum power.

$7 \frac{1}{2}$

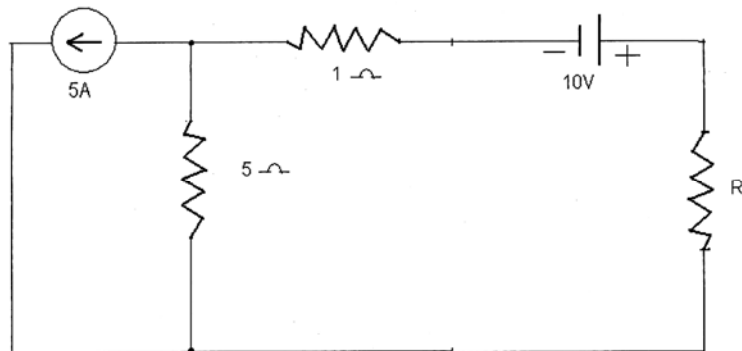



- b) Find the current in 2Ω resistor in figure using Norton's Theorem.

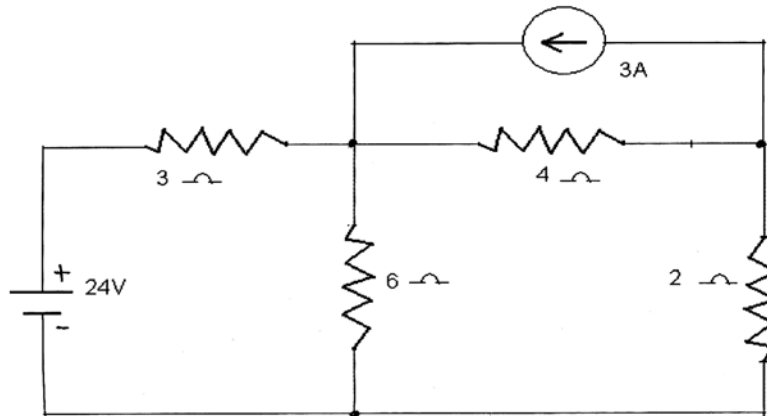

9. a) Explain with reasons as to why transformer core is made of silicon steel laminations.
- b) Draw the vector diagram of a single phase transformer for a leading power load. Level all the vectors.
- c) The open circuit and short circuit test data of a 12kVA, 200/400volt and 50Hz single phase transformer are
- i) O.C test Primary voltage = 200 volts
No load current = 1.3A, W = 120w
 - ii) S.C test Primary voltage = 22 volts
Secondary current = 30A, W=200w
- Find the parameters of the equivalent circuit. 3 + 6 + 6

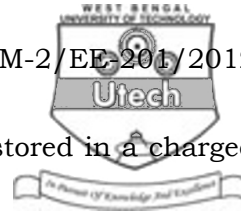

10. a) Derive an expression for the energy stored in a charged capacitor.
- b) Find the greatest mechanical force produced electrostatically that can be exerted on 1 cm^2 of conducting material in air. Assume that air become conducting at a voltage gradient of 30kV per cm .
- c) Three charges of $+ 2 \times 10^{-10}\text{C}$, $- 8 \times 10^{-10} \text{ C}$ and $+ 4 \times 10^{-10} \text{ C}$ are placed at the three corners B , C and D respectively of a rectangle $ABCD$ whose side $AB = 5 \text{ cm}$, and $BC = 7 \text{ cm}$. Calculate the potential at corner A of the rectangle. 3 + 6 + 6
11. a) 'A 3-phase induction motor is self-starting'—why ?
- b) Obtain the relation between the slip and frequency of the rotor induced e.m.f.
- c) A 4-pole, 3-phase, 275kW , 440V , 50Hz induction motor is running with a slip of 4% . Find
- i) synchronous speed
 - ii) rotor speed
 - iii) frequency of rotor induced e.m.f.
- d) Derive an expression for torque-slip characteristics of a 3-phase induction motor. 3 + 6 + 6
12. A sinusoidal voltage $282.4 \sin wt$ is applied in a full wave rectifier circuit. Calculate the average and r.m.s. value and also determine the form factor and peak factor of the output wave. 15